

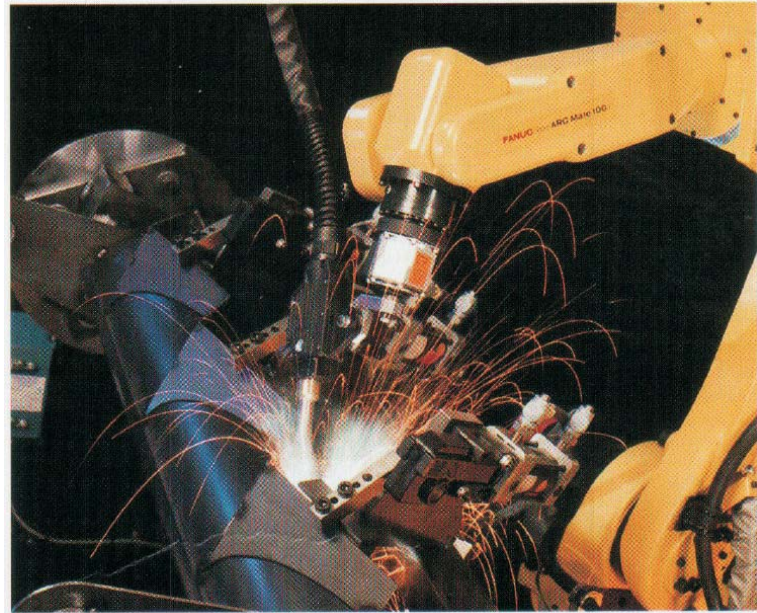

FANUC ROBOTICS ArcMate100i

ARC Mate 100i Specifications

Items		Range	Speed
Motion range and speed	Axis 1	330°	120°/sec
	Axis 2	210°	120°/sec
	Axis 3	299°	120°/sec
	Axis 4	380°	360°/sec
	Axis 5	280°	360°/sec
	Axis 6	640°	450°/sec
Wrist load moments	Axis 4	1.6kgf • m	
	Axis 5	1.0kgf • m	
	Axis 6	0.6kgf • m	
Wrist load inertias	Axis 4	6.4kgf • cm • s ²	
	Axis 5	2.0kgf • cm • s ²	
	Axis 6	0.6kgf • cm • s ²	
Repeatability		±0.1mm (±0.004")	
Maximum load capacity	Wrist	6kg (13.2 lbs)	
	Axis 3	12kg (26.4 lbs)	
Mounting method		Upright (inverted, wall and angle mount for remote i-Controller only)	
Mechanical Brakes		Axis 2 and 3 (6 axis brake option)	
Weight		290kg (639 lbs) including integrated i-controller	



2Ri Robotics carries a wide selection of high-quality used robots, in stock and ready for shipment. Each component has undergone extensive reconditioning and passed rigorous testing to guarantee years of service and dependability

Top

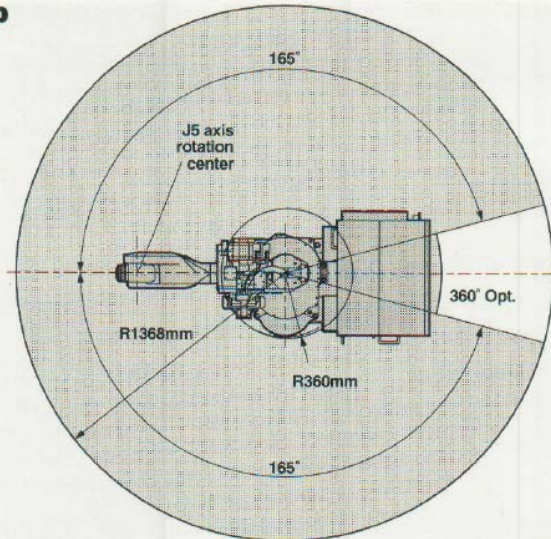

Side

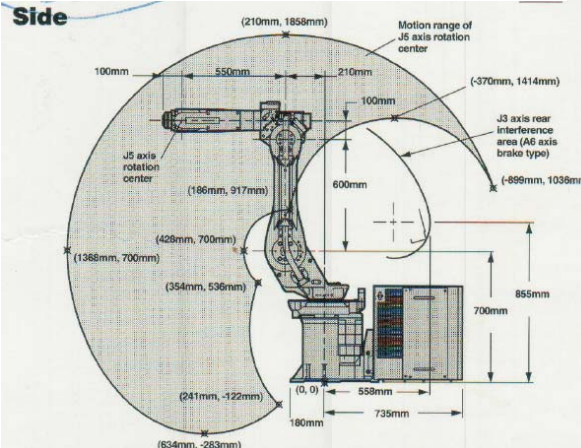

Front

