

# Dell™ Dimension™ 1100/B110 Systems Service Manual

[Before You Begin](#)

[Removing the Computer Cover](#)

[Technical Overview](#)

[Technical Specifications](#)

[Advanced Troubleshooting](#)

[System Setup](#)

[Removing and Installing Parts](#)

[Replacing the Computer Cover](#)

---

## Notes, Notices, and Cautions



**NOTE:** A NOTE indicates important information that helps you make better use of your computer.



**NOTICE:** A NOTICE indicates either potential damage to hardware or loss of data and tells you how to avoid the problem.



**CAUTION:** A CAUTION indicates a potential for property damage, personal injury, or death.

## Abbreviations and Acronyms

For a complete list of abbreviations and acronyms, see the *Dell Dimension Help* file.

If you purchased a Dell™ n Series computer, any references in this document to Microsoft® Windows® operating systems are not applicable.

---

**Information in this document is subject to change without notice.**

**© 2006 Dell Inc. All rights reserved.**

Reproduction in any manner whatsoever without the written permission of Dell Inc. is strictly forbidden.

Trademarks used in this text: *Dell*, the *DELL* logo, *Inspiron*, *Dell Precision*, *Dimension*, *OptiPlex*, *Latitude*, *PowerEdge*, *PowerVault*, *PowerApp*, and *Dell OpenManage* are trademarks of Dell Inc.; *Intel*, *Pentium*, and *Celeron* are registered trademarks of Intel Corporation; *Microsoft* and *Windows* are registered trademarks of Microsoft Corporation.

Other trademarks and trade names may be used in this document to refer to either the entities claiming the marks and names or their products. Dell Inc. disclaims any proprietary interest in trademarks and trade names other than its own.

Model DMC    August 2006    Rev. A02

# Before You Begin

## Dell™ Dimension™ 1100/B110 Systems Service Manual

- [Getting Started](#)
  - [Recommended Tools](#)
  - [Turning Off Your Computer](#)
  - [Before Working Inside Your Computer](#)
- 

## Getting Started

This chapter provides procedures for removing and installing the components in your computer. Unless otherwise noted, each procedure assumes that the following conditions exist:

- You have performed the steps in [Turning Off Your Computer](#) and [Before Working Inside Your Computer](#).
  - You have read the safety information in your Dell™ *Product Information Guide*.
  - A component can be replaced or—if purchased separately—installed by performing the removal procedure in reverse order.
- 

## Recommended Tools

The procedures in this document may require the following tools:

- Small flat-blade screwdriver
  - Phillips screwdriver
- 

## Turning Off Your Computer

 **NOTICE:** To avoid losing data, save and close any open files and exit any open programs before you turn off your computer.

1. Shut down the operating system:
  - a. Save and close any open files, exit any open programs, click the **Start** button, and then click **Turn Off Computer**.
  - b. In the **Turn off computer** window, click **Turn off**.

The computer turns off after the operating system shutdown process finishes.

2. Ensure that the computer and any attached devices are turned off. If your computer and attached devices did not automatically turn off when you shut down your operating system, press and hold the power button for 4 seconds.
- 

## Before Working Inside Your Computer

Use the following safety guidelines to help protect your computer from potential damage and to help ensure your own personal safety.

 **CAUTION:** Before you begin any of the procedures in this section, follow the safety instructions located in the *Product Information Guide*.

 **CAUTION:** Handle components and cards with care. Do not touch the components or contacts on a card. Hold a card by its edges or by its metal mounting bracket. Hold a component such as a processor by its edges, not by its pins.

 **NOTICE:** Only a certified service technician should perform repairs on your computer. Damage due to servicing that is not authorized by Dell is not covered by your warranty.

 **NOTICE:** When you disconnect a cable, pull on its connector or on its strain-relief loop, not on the cable itself. Some cables have a connector with locking tabs; if you are disconnecting this type of cable, press in on the locking tabs before you disconnect the cable. As you pull connectors apart, keep them evenly aligned to avoid bending any connector pins. Also, before you connect a cable, ensure that both connectors are correctly oriented and aligned.

 **NOTICE:** To avoid damaging the computer, perform the following steps before you begin working inside the computer.

1. [Turn off your computer.](#)

 **NOTICE:** To disconnect a network cable, first unplug the cable from your computer and then unplug it from the network wall jack.

2. Disconnect any telephone or telecommunication lines from the computer.
3. Disconnect your computer and all attached devices from their electrical outlets, and then press the power button to ground the system board.



 **CAUTION:** To guard against electrical shock, always unplug your computer from the electrical outlet before opening the cover.

4. [Open the computer cover.](#)

 **NOTICE:** Before touching anything inside your computer, ground yourself by touching an unpainted metal surface, such as the metal at the back of the computer. While you work, periodically touch an unpainted metal surface to dissipate any static electricity that could harm internal components.

# Removing the Computer Cover

## Dell™ Dimension™ 1100/B110 Systems Service Manual

-  **CAUTION:** Before you begin any of the procedures in this section, follow the safety instructions located in the *Product Information Guide*.
-  **CAUTION:** To guard against electrical shock, always unplug your computer from the electrical outlet before opening the cover.

1. Follow the procedures in [Before You Begin](#).
2. Lay your computer on its side with the computer cover facing up.
3. If your computer cover has a cover latch, slide and hold the cover latch.
4. Grip the indents on the computer cover, and slide the computer cover toward the back of the computer.

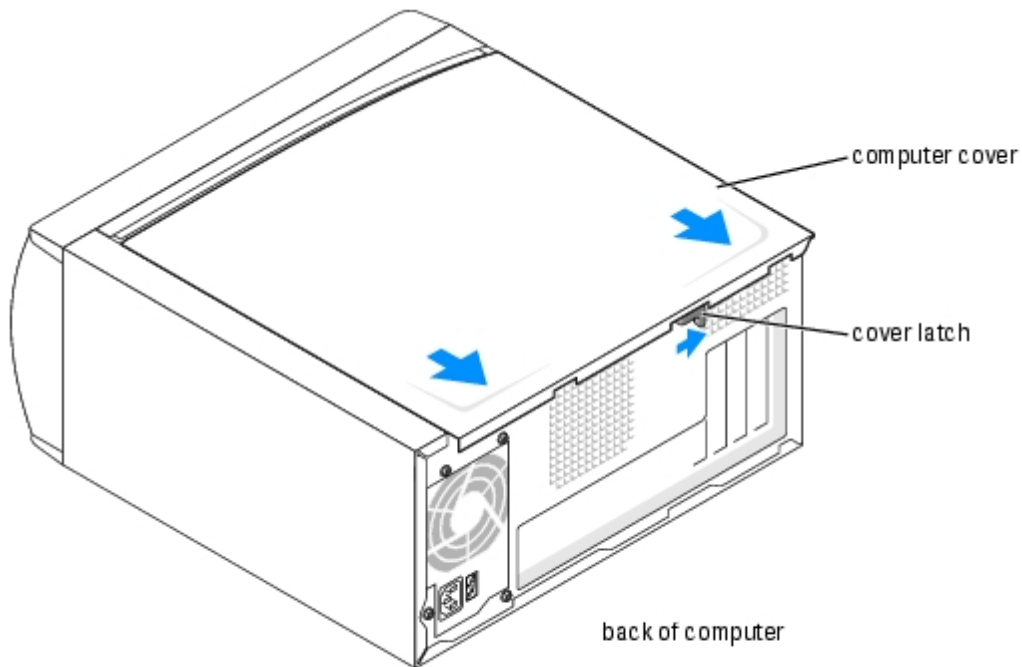

5. Place the computer cover on a level surface.

# Technical Overview

## Dell™ Dimension™ 1100/B110 Systems Service Manual

- [Inside View of Your Computer](#)
  - [System Board Components](#)
  - [Power Supply DC Connector Pin Assignments](#)
- 

## Inside View of Your Computer

**⚠ CAUTION:** Before you begin any of the procedures in this section, see the safety instructions located in the *Product Information Guide*.

**⚠ CAUTION:** To guard against electrical shock, always unplug your computer from the electrical outlet before opening the computer cover.

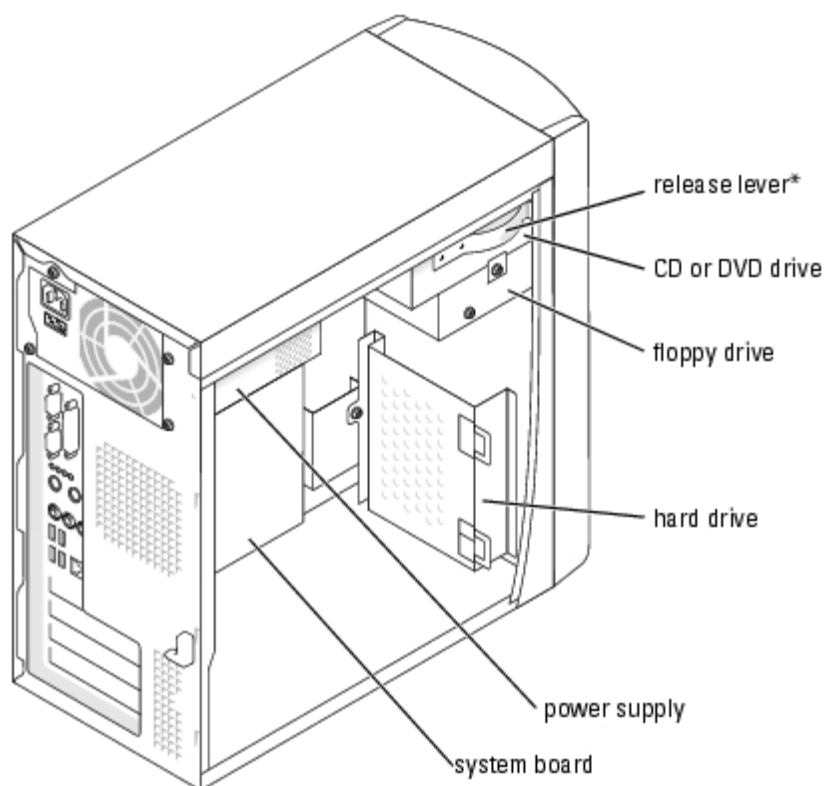

\*May not be present on all computers.

---

## System Board Components

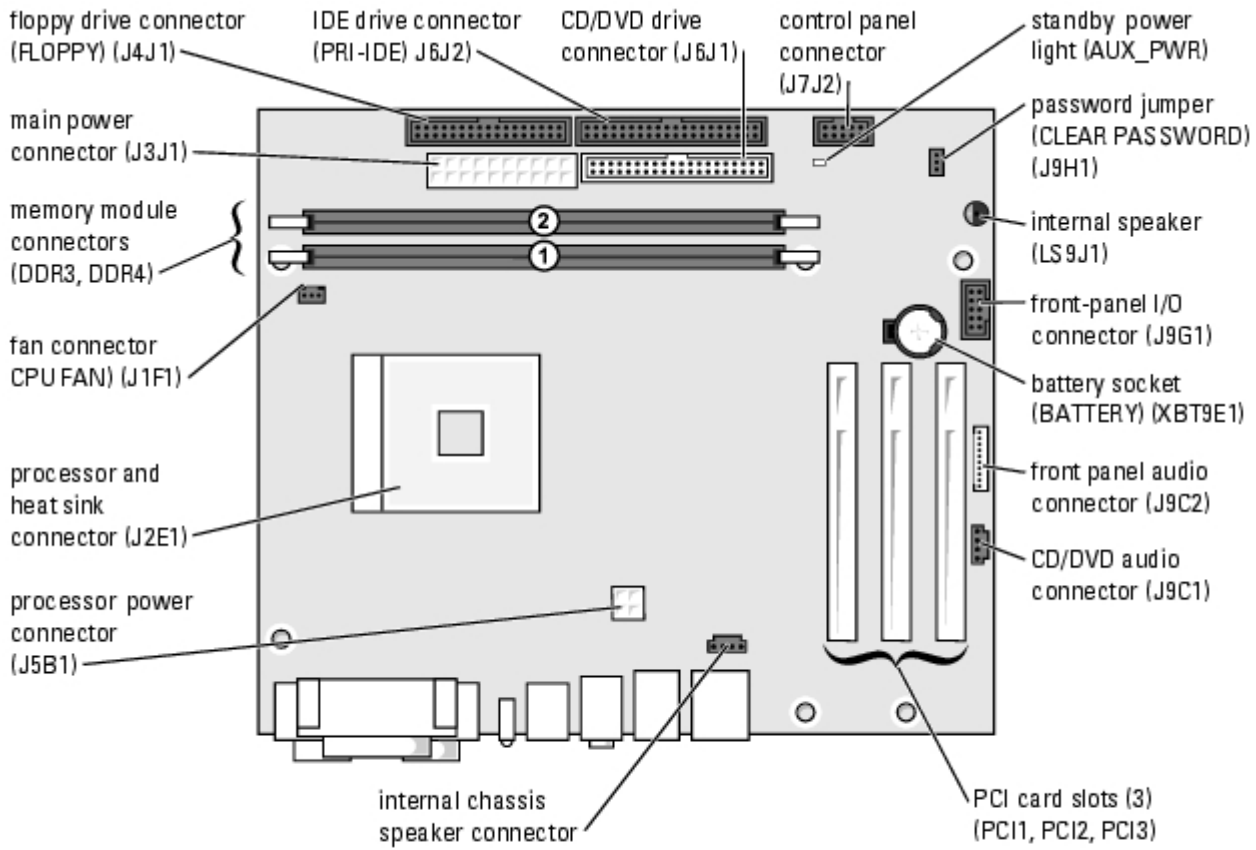

## Power Supply DC Connector Pin Assignments

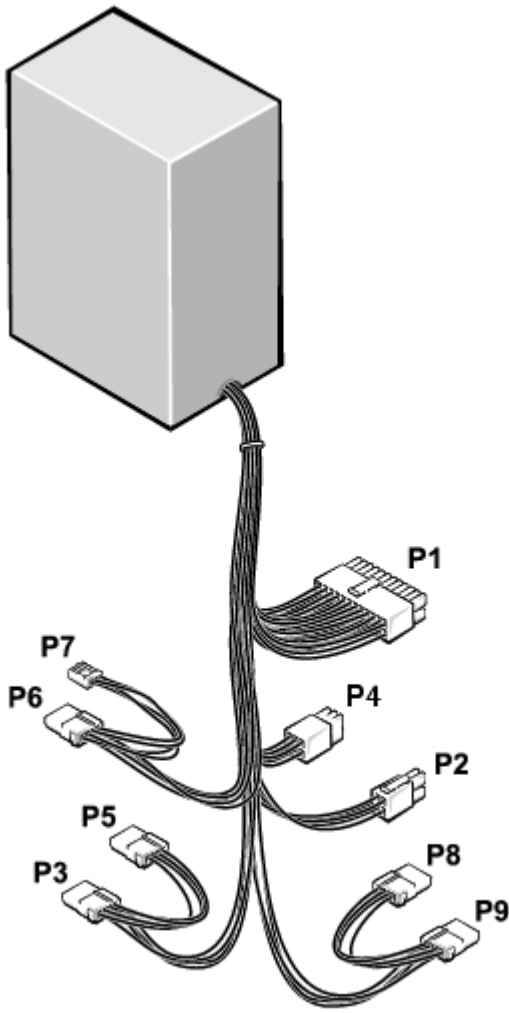

The 250-W power supply can operate from an AC power source of 115 VAC or 230 VAC at 50 – 60 Hz. The power supply provides the DC operating voltages and currents listed in the following table.

Output Voltage <sup>1</sup>	Minimum Current (A)	Maximum Current (A) <sup>2</sup>
+12 VDC	0.0	16.0 <sup>3</sup>
+5 VDC	1.0/0.2 <sup>4</sup>	22.0
+3.3 VDC	0.1/0.0 <sup>5</sup>	18.0
-	-	-
-12 VDC	0.0	1.0
+5 VFP	0.0	2.0

<sup>1</sup>Outputs will meet and not exceed SELV requirements per electrical standards, i.e. UL 60950, IEC 60950, EN60950 PAR.2.3.

<sup>2</sup>Maximum continuous combined load on +5 VDC and +3.3 VDC outputs will not exceed 150 watts.

<sup>3</sup>Peak +12 VDC output power (up to 17.0 amps) will not exceed 15 seconds in duration. Under this condition, tolerance on the +12v output, is allowed to be +/- 10%.

<sup>4</sup>+5 VDC minimum load will be 0.2A when there is a minimum load of 0.3A on the +12 VDC and 0.42A on the +3.3 VDC outputs simultaneously. +5V min load is 1A for load transient tests.

<sup>5</sup>In system applications where +3.3VDC is not used, all other outputs will stay within regulation while the +3.3 VDC output

is in a zero load condition.

## DC Power Connector P1

**NOTE:** The +3.3 VDC output wires (orange) must be 16 AWG. All other output wires must be 18 AWG.

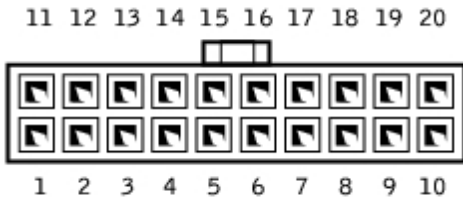

Pin Number	Signal name	Wire Color
1	+3.3 VDC	Orange
2	+3.3 VDC	Orange
3	COM	Black
4	+5 VDC	Red
5	COM	Black
6	+5 VDC	Red
7	COM	Black
8	POK	Gray
9	+5 VFP	Purple
10	+12 VDC	Yellow
11	+3.3 VDC	Orange
12	-12 VDC	Blue
13	COM	Black
14	PS_ON	Green
15	COM	Black
16	COM	Black
17	COM	Black
18	N/C	N/C
19	+5 VDC	Red
20	+5 VDC	Red

## DC Power Connector P2





Pin Number	Signal Name	18-AWG Wire Color
1	COM	Black
2	COM	Black
3	+12 VDC	Yellow
4	+12 VDC	Yellow

## DC Power Connectors P8 and P9

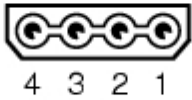

Pin Number	Signal Name	18-AWG Wire Color
1	+12 VDC	Yellow
2	COM	Black
3	COM	Black
4	+5 VDC	Red

## DC Power Connector P4

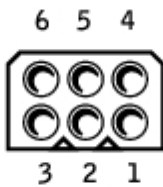

Pin Number	Signal Name	18-AWG Wire Color
1	-	No connect
2	COM	Black
3	COM	Black
4	+3.3 VDC	Orange
5	+5 VDC	Red
6	+12 VDC	Yellow

## DC Power Connector P6



4 3 2 1

Pin Number	Signal Name	18-AWG Wire Color
1	+12 VDC	Yellow
2	COM	Black
3	COM	Black
4	+5 VDC	Red

## DC Power Connector P7



4 3 2 1

Pin Number	Signal Name	22-AWG Wire Color
1	+5 VDC	Red
2	COM	Black
3	COM	Black
4	+12 VDC	Yellow

---

[Back to Contents Page](#)

# Technical Specifications

## Dell™ Dimension™ 1100/B110 Systems Service Manual

Processor	
Processor type	Intel® Pentium® 4 with HT Technology and Intel Celeron®  <b>NOTE:</b> Not all Pentium 4 processors support Hyper-Threading technology.
Level 1 (L1) cache	8 KB
Level 2 (L2) cache	128-KB or 512-KB (depending on your computer configuration) pipelined-burst, eight-way set associative, write-back SRAM

<b>Memory</b>	
Type	333- and 400-MHz DDR SDRAM  <b>NOTE:</b> DDR333 and DDR400 memory runs at 266MHz when configured with Celeron 400MHz FSB processors  <b>NOTE:</b> DDR333 memory runs at 320MHz when configured with Pentium 4 800MHz FSB processors
Memory connectors	two
Memory capacities	128-, 256-, 512-, or 1-GB non-ECC
Minimum memory	128 MB  <b>NOTE:</b> Between 1 and 64 MB of system memory may be allocated to support graphics, depending on system memory size and other factors.
Maximum memory	2 GB
BIOS address	F0000h

<b>Computer Information</b>	
Chip set	Intel 865 GV
DMA channels	Seven
Interrupt levels	24
BIOS chip (NVRAM)	4 Mb
NIC	integrated network interface capable of 10/100 communication.
System Clock	Intel Pentium 4: 800 MHz

Intel Celeron: 533 MHz
------------------------

## Video

Type	Integrated Intel Extreme Graphics 2
------	-------------------------------------

## Audio

Type	AC97, Sound Blaster Emulation, ADI 1980 audio controller with 2.1 implementation
------	--

## Expansion Bus

Bus type	PCI
Bus speed	33 MHz
PCI connectors	three
connector size	120 pins
connector data width (maximum)	32 bits

## Drives

### Externally accessible:

	One bay for a floppy drive, and two bays for CD/DVD drives
Available devices	Floppy drive, USB memory devices, CD drive, CD-RW drive, DVD drive, DVD-RW drive, and DVD and CD-RW combo drive

### Internally accessible:

	One bay for 1-inch-high IDE hard drives
--	---

## Connectors

### External connectors:

Serial	9-pin connector; 16550C-compatible
Parallel	25-hole connector (bidirectional)
Video	15-hole connector
Network adapter	RJ45 connector
PS/2 (keyboard and mouse)	6-pin mini-DIN
USB	two front-panel and four back-panel USB 2.0-compliant connectors
Audio	Three connectors for line-in, line-out, and microphone; one front-panel connector for headphones

### System board connectors:

Primary IDE drive	40-pin connector on PCI local bus
-------------------	-----------------------------------

Secondary IDE drive	40-pin connector on PCI local bus
Floppy drive	34-pin connector
CD Audio	4-pin connector
Fan	3-pin connector

<b>Controls and Lights</b>	
Power control	Push button
Hard-drive access light	Green
Link integrity light (on integrated network adapter)	No light for 10-Mb operation; green light for 100-Mb operation
Activity light (on integrated network adapter)	Yellow blinking light
Diagnostic lights	Four lights on the back panel

<b>Power</b>	
DC power supply:	
Wattage	250 W
Heat dissipation	853 BTU/hr <b>NOTE:</b> Heat dissipation is calculated based upon the power supply wattage rating.
Voltage (see the safety instructions located in the <i>Product Information Guide</i> for important voltage setting information)	manual selection power supplies — 90 to 135 V at 50/60 Hz; 180 to 265 V at 50/60 Hz
Backup battery	3-V CR2032 lithium coin cell

<b>Physical</b>	
Height x width x depth	41.9 x 18.1 x 36.8 cm (16.5 x 7.13 x 14.50 inches)
Weight	11.34 kg (25 lb)

<b>Environmental</b>	
Temperature:	
Operating	10° to 30°C (50° to 86°F) <b>NOTE:</b> At 30°C (86°F), the maximum operating altitude is 914 m (3000 ft).
Storage	–40° to 65°C (–40° to 149°F)
Relative humidity	20% to 80% (noncondensing)
Maximum vibration:	
Operating	0.25 G at 3 to 200 Hz at 0.5 octave/min
Storage	2.20 Grms at 10 to 500 Hz at 1 octave/min

Maximum shock:	
Operating	105 G, 2 ms
Storage	32 G with a velocity change of 596.9 cm/sec (235 inches/sec)
Altitude:	
Operating	-15.2 to 3048 m (-50 to 10,000 ft)  <b>NOTE:</b> At 30°C (95°F), the maximum operating altitude is 914 m (3000 ft).
Storage	-15.2 to 10,670 m (-50 to 35,000 ft)

---

[Back to Contents Page](#)

# Advanced Troubleshooting

## Dell™ Dimension™ 1100/B110 Systems Service Manual

- [Power Lights](#)
- [Network Lights](#)
- [Diagnostic Lights](#)
- [Beep Codes](#)
- [System Messages](#)

---

## Power Lights

The power button light located on the front of your computer illuminates and blinks or remains solid to indicate different states:

- If the power light is green, the power status is good and the computer is functioning properly.
- If the power light is green and the computer is not responding, see [Network Lights](#).
- If the power light is blinking green, the computer is in standby mode. Press a key on the keyboard or move the mouse to resume normal operation.
- If the power light is off, the computer is either turned off or is not receiving power.
  - Reseat the power cable into both the power connector on the back of the computer and the electrical outlet.
  - If the computer is plugged into a power strip, ensure that the power strip is plugged into an electrical outlet and that the power strip is turned on. Also bypass power protection devices, power strips, and power extension cables to verify that the computer turns on properly.
  - Ensure that the electrical outlet is working by testing it with another device, such as a lamp.
  - Ensure that the main power cable and front panel cable are securely connected to the system board.
- If the power light is blinking amber, the computer is receiving electrical power, but an internal power problem might exist.
  - Ensure that the voltage selection switch is set to match the AC power at your location (if applicable).
  - Ensure that the processor power cable is securely connected to the system board.
- If the power light is steady amber, a device might be malfunctioning or incorrectly installed.
  - Remove and then [reinstall the memory modules](#).
  - Remove and then reinstall any cards.
  - Remove and then reinstall the graphics card, if applicable.

---

## Network Lights







	100 Mb Link		10 Mb Link		No Link
	Active	Non-active	Active	Non-active	
	blinking	on	blinking	on	off

Yellow LED					
Green LED	on	on	off	off	off





## Diagnostic Lights

**⚠ CAUTION:** Before you begin any of the procedures in this section, follow the safety instructions located in the *Product Information Guide*.

To help you troubleshoot a problem, your computer has four lights labeled "A," "B," "C," and "D" on the back panel. The lights can be yellow or green. When the computer starts normally, the lights flash. After the computer starts, all four lights display solid green. If the computer malfunctions, the color and sequence of the lights identify the problem.

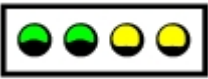
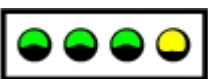
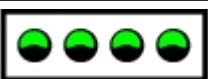
Light Pattern	Problem Description	Suggested Resolution
 A B C D	The computer is in a normal off condition or a possible pre-BIOS failure has occurred.	Plug the computer into a working electrical outlet and press the power button.
 A B C D	Memory modules are detected, but a memory failure has occurred.	<ul style="list-style-type: none"> <li>If you have one memory module installed, <a href="#">reinstall the memory module</a> and restart the computer.</li> <li>If you have two or more memory modules installed, remove the modules, <a href="#">reinstall one memory module</a>, and then restart the computer. If the computer starts normally, reinstall an additional module. Continue until you have identified a faulty module or reinstalled all modules without error.</li> <li>If available, <a href="#">install properly working memory</a> of the same type into your computer.</li> <li>If the problem persists, see "Contacting Dell" in your <i>Owner's Manual</i> for instructions on obtaining technical assistance.</li> </ul>
 A B C D	A possible graphics card failure has occurred.	<ul style="list-style-type: none"> <li>If the computer has a graphics card, remove the card, reinstall it, and then restart the computer.</li> <li>If the problem still exists, install a graphics card that you know works and restart the computer.</li> <li>If the problem persists or the computer has integrated graphics, see "Contacting Dell" in your <i>Owner's Manual</i> for instructions on obtaining technical assistance.</li> </ul>
 A B C D	A possible floppy or hard drive failure has occurred.	Reseat all power and data cables and restart the computer.
 A B C D	A possible USB failure has occurred.	Reinstall all USB devices, check cable connections, and then restart the computer.
 A B C D	Memory modules are detected, but a memory configuration or compatibility error exists.	<ul style="list-style-type: none"> <li>Ensure that no special memory module/memory connector placement requirements exist (see Specifications).</li> <li>Verify that the memory modules that you are installing are compatible with your computer (see Specifications).</li> <li>If the problem persists, see "Contacting Dell" in your <i>Owner's Manual</i> for instructions on obtaining technical assistance.</li> </ul>
	A possible expansion card failure has	1. Determine if a conflict exists by removing a card (not a graphics card) and restarting the computer.



 <p>A B C D</p>	<p>occurred.</p>	<ol style="list-style-type: none"> <li>2. If the problem persists, reinstall the card that you removed, remove a different card, and then restart the computer.</li> <li>3. Repeat this process for each card. If the computer starts normally, troubleshoot the last card removed from the computer for resource conflicts.</li> <li>4. If the problem persists, see "Contacting Dell" in your <i>Owner's Manual</i> for instructions on obtaining technical assistance.</li> </ol>
 <p>A B C D</p>	<p>Another failure has occurred.</p>	<ul style="list-style-type: none"> <li>• Ensure that the cables are properly connected to the <a href="#">system board</a> from the hard drive, CD drive, and DVD drive.</li> <li>• If there is an error message on your screen identifying a problem with a device (such as the floppy drive or hard drive), check the device to make sure it is functioning properly.</li> <li>• The operating system is attempting to boot from a device (such as the floppy drive or hard drive); check <a href="#">system setup</a> to make sure that the boot sequence is correct for the devices installed on your computer.</li> <li>• If the problem persists, see "Contacting Dell" in your <i>Owner's Manual</i> for instructions on obtaining technical assistance.</li> </ul>
 <p>A B C D</p>	<p>The computer is in a normal operating condition after POST.</p>	<p>None.</p>
<p>  = yellow   = green   = off </p>		

## Beep Codes

Your computer might emit a series of beeps during start-up if the monitor cannot display errors or problems. This series of beeps, called a beep code, identifies a problem. One possible beep code (code 1-3-1) consists of one beep, a burst of three beeps, and then one beep. This beep code tells you that the computer encountered a memory problem.

Reseating the memory modules may fix the beep code errors in the following table. If the problem persists, see "Contacting Dell" in your *Owner's Manual* for instructions on obtaining technical assistance.

Code	Cause
1-3-1 through 2-4-4	Memory not being properly identified or used
4-3-1	Memory failure above address OFFFh

If you hear one of the following beep codes, see "Contacting Dell" in your *Owner's Manual* for instructions on obtaining technical assistance.

Code	Cause
1-1-2	Microprocessor register failure
1-1-3	NVRAM
1-1-4	ROM BIOS checksum failure
1-2-1	Programmable interval timer
1-2-2	DMA initialization failure
1-2-3	DMA page register read/write failure

3-1-1	Slave DMA register failure
3-1-2	Master DMA register failure
3-1-3	Master interrupt mask register failure
3-1-4	Slave interrupt mask register failure
3-2-2	Interrupt vector loading failure
3-2-4	Keyboard Controller Test failure
3-3-1	NVRAM power loss
3-3-2	NVRAM configuration
3-3-4	Video Memory Test failure
3-4-1	Screen initialization failure
3-4-2	Screen retrace failure
3-4-3	Search for video ROM failure
4-2-1	No time tick
4-2-2	Shutdown failure
4-2-3	Gate A20 failure
4-2-4	Unexpected interrupt in protected mode
4-3-3	Timer-chip counter 2 failure
4-3-4	Time-of-day clock stopped
4-4-1	Serial or parallel port test failure
4-4-4	Cache test failure

## System Messages



**NOTE:** If the message you received is not listed in the table, see the documentation for either the operating system or the program that was running when the message appeared.

Message	Possible Cause	Corrective Action
8042 Gate-A20 error	The keyboard controller failed its test.	If you receive this message after you make changes in the system setup program, enter the system setup program and restore the original value(s).
Address Line Short!	An error in the address decoding circuitry in the memory has occurred.	<a href="#">Reseat the memory modules.</a>
C: Drive Error C: Drive Failure	The hard drive is not working or is not configured correctly.	Ensure that the drive is installed correctly in the computer and defined correctly in the <a href="#">system setup program</a> .
Cache Memory Bad, Do Not Enable Cache	The cache memory is not operating.	See "Contacting Dell" in your <i>Owner's Manual</i> for instructions on obtaining technical assistance.
CH-2 Timer Error	An error is occurring on the timer on the system board.	See "Contacting Dell" in your <i>Owner's Manual</i> for instructions on obtaining technical assistance.
CMOS Battery State Low	The system configuration information in the system setup	<a href="#">Enter the system setup program</a> , verify the system configuration, and then restart the

CMOS Checksum Failure	program is incorrect or the battery charge may be low.	computer.
CMOS System Options Not Set		
CMOS Display Type Mismatch		
CMOS Memory Size Mismatch		
CMOS Time and Date Not Set		
Diskette Boot Failure	Drive A or B is present but has failed the BIOS POST.	Ensure that the drive is installed correctly in the computer and defined correctly in the <a href="#">system setup program</a> . Check the interface cable at both ends.
DMA Error DMA 1 Error DMA 2 Error	Error in the DMA controller on the system board.	The keyboard or <a href="#">system board</a> may need to be replaced.
FDD Controller Failure HDD Controller Failure	The BIOS cannot communicate with the floppy drive or hard drive controller.	Ensure that the drive is installed correctly in the computer and defined correctly in the <a href="#">system setup program</a> . Check the interface cable at both ends.
INTR1 Error INTR2 Error	An interrupt channel on the system board failed to POST.	The keyboard or <a href="#">system board</a> may need to be replaced.
Invalid Boot Diskette	The operating system cannot be located on drive A or drive C.	<a href="#">Enter the system setup program</a> and confirm that drive A or drive C is properly identified.
Keyboard Error	The BIOS has detected a stuck key.	Ensure that nothing is resting on the keyboard; if a key appears to be stuck, carefully pry it up. If the problem persists, you may need to replace the keyboard.
KB/Interface Error	An error occurred with the keyboard connector.	Ensure that nothing is resting on the keyboard; if a key appears to be stuck, carefully pry it up. If the problem persists, you may need to replace the keyboard.
No ROM Basic	The operating system cannot be located on drive A or drive C.	<a href="#">Enter the system setup program</a> and confirm that drive A or drive C is properly identified.

---

[Back to Contents Page](#)

# System Setup

## Dell™ Dimension™ 1100/B110 Systems Service Manual

- [Overview](#)
- [Entering System Setup](#)
- [System Setup Screens](#)
- [System Setup Options](#)
- [Boot Sequence](#)
- [Clearing Forgotten Passwords](#)

---

## Overview

Use system setup as follows:

- To change the system configuration information after you add, change, or remove any hardware in your computer
- To set or change a user-selectable option such as the user password
- To read the current amount of memory or set the type of hard drive installed

Before you use system setup, it is recommended that you write down the system setup screen information for future reference.

 **NOTICE:** Unless you are an expert computer user, do not change the settings for this program. Certain changes can make your computer work incorrectly.

---

## Entering System Setup

1. Turn on (or restart) your computer.
2. When the blue DELL™ logo appears, press <F2> immediately.

If you wait too long and the operating system logo appears, continue to wait until you see the Microsoft® Windows® desktop. Then [shut down your computer](#) and try again.

---

## System Setup Screens

The system setup screen displays current or changeable configuration information for your computer. Information on the screen is divided into three areas: the options list, active options field, and key functions.

**Options List** — This field appears on the left side of the system setup

**Option Field** — This field contains information about each option. In this field you can view your current settings and make changes to your settings.

Use the right- and left-arrow keys to highlight an option. Press <Enter> to make that selection active.

window. The field is a scrolling list of features that define the configuration of your computer, including installed hardware, power conservation, and security features.

Scroll up and down the list by using the up- and down-arrow keys. As an option is highlighted, the **Option Field** displays more information about that option and the option's current and available settings.

Press <Enter> to expand or contract each of the main option fields.

Key Functions — This field appears below the **Option Field** and lists keys and their functions within the active system setup field.

## System Setup Options

 **NOTE:** Depending on your computer and installed devices, the items listed in this section may not appear, or may not appear exactly as listed.

<b>System</b>	
System Time	Lists system time in hours, minutes, and seconds.
System Date	Identifies the date as formatted: Weekday Month
<b>Drive Configuration</b>	
Diskette Drive	Identifies and defines the floppy drive attached to the FLOPPY connector on the system board as <b>Off</b> , <b>USB</b> , <b>Internal</b> , or <b>Read Only</b> .
Primary Master Drive	Identifies the drive attached to the PRI IDE connectors on the system board, and lists the capacity for a hard drive.
Primary Slave Drive	Identifies and defines the slave drive to the primary master drive on PRI IDE. Can be turned <b>Off</b> or set to <b>Auto</b> (to detect the drive) and if present, lists the capacity for the drive.
Secondary Master Drive	Identifies the drive attached to the SEC IDE connectors on the system board, and lists the capacity for a hard drive (lists <b>n/a</b> for optical devices such as CD/DVD drives).
Secondary Slave Drive	Identifies and defines the slave drive to the secondary master drive on SEC IDE. Can be turned <b>Off</b> or set to <b>Auto</b> (to detect the drive) and if present, lists the capacity for the drives (lists <b>n/a</b> for optical devices such as CD/DVD drives).
IDE Drive UDMA	Identifies whether or not to enable UDMA (the Ultra Direct Memory Access mass storage interface).
<b>Hard-Disk Drive Sequence</b>	
	<p>Identifies the device types that are in first and second priority for booting the system.</p> <ul style="list-style-type: none"> <li>• System BIOS - devices such as hard drives and CD/DVD ROMs as listed in the Boot Sequence section of this System Setup program</li> <li>• USB device - a device such as an external hard drive or USB memory key</li> </ul> <p>By default, <b>System BIOS boot devices</b> is first (in position 1), followed by <b>USB device</b>. To change the order, select an option and press the + or - key to move the selection up or down in priority.</p> <p><b>NOTE:</b> If you insert a boot device and restart the computer, this option appears in the System Setup menu. To boot from a USB memory device, select the USB device and move it so it becomes the first device in the list.</p>

## Boot Sequence

Lists the drives in the order by which they boot.

- Floppy device - Identifies and defines the floppy drive attached to the FLOPPY connector on the system board. If there is no installed drive, it appears as **Floppy device (not installed)**.
- Hard-Disk Drive - Identifies the hard drive. The drive is listed by its drive letter (such as **Hard Disk Drive C:**).
- IDE - Identifies and defines the optical drive attached to the IDE connector on the system board. If there is no installed drive, it appears as **IDE CD-ROM Device (not installed)**.

An included device displays with a checkmark next to its listing. To remove the device from the boot sequence, use the spacebar to clear the checkmark. To change the boot order, use + or - to move the listing up or down.

## Memory Information

Installed System Memory

Identifies and lists the amount of detected memory.

System Memory Speed

Identifies and lists the speed of the detected memory in megahertz (MHz). For information on supported memory see [Memory](#).

System Channel Mode

Identifies and lists the installed memory as either **Dual** or **Single** channel. For information on supported memory see [Memory](#).

AGP Aperture

Identifies and lists the amount of memory dedicated for graphics. The values vary depending on the capacity of installed memory.

## CPU Information

Hyperthreading

If your computer's processor supports Hyper-Threading, this section displays the following options:

- Disabled - Hyper-Threading is Off.
- **Enabled** - Hyper-Threading is On.

CPU Speed

Lists the options for setting the processor speed as **Normal** or **Compatible**.

**NOTICE:** Changing the CPU Speed is not recommended, this may shorten the life of the processor and void the warranty.

Bus Speed

Lists the speed that the processor runs in megahertz (MHz).

Processor ID

Lists the processor **Clock Speed**, and **L2 Cache Size**.

## Integrated Devices

Sound

Enables or disables the onboard audio controller.

Network Interface Controller

You can set the NIC to **On** (default), **Off**, or **On w/ PXE**. When the **On w/ PXE** setting is active (available only for the future boot process), the computer prompts the user to press <Ctrl><Alt><b>. Pressing this key combination displays a menu that allows you to select a method for booting from a network server. If a boot routine is not available from the network server, the computer attempts to boot from the next device in the boot sequence list.

Mouse Port

Enables or disables the onboard PS/2-compatible mouse controller.

USB Emulation

Set to **On** (default) so that USB devices will be detected and supported in the operating system.

The **No Boot** option restricts external access to drive data. Use this option to prohibit users from booting the computer using an external USB device.

USB Controller

Set to **On** (default) so that multiple USB devices can be connected to a system without compromising data speed. When set to **Off**, all connected ports share a set data speed that is equivalent to one port.

Serial Port #1

Identifies and defines the serial port settings. **Auto**, the default setting, automatically configures a connector to a particular designation (**COM1** or **COM3**).

Parallel Port Mode

Identifies and defines the parallel port settings. You can set the parallel port to **Off**, **AT**, **PS/2**, **EPP**, or **ECP**.

Parallel Port I/O Address	Identifies the address for the parallel port.
Diskette Interface	Identifies and defines the floppy drive interface. You can set the interface to <b>Auto</b> , <b>Read Only</b> , or <b>Off</b> .
Primary Video Controller	This setting specifies which video controller is primary when two video controllers are present on the computer.
Onboard Video Controller	Sets the amount of system memory to be reserved for the onboard video controller.
<b>Power Management</b>	
Suspend Mode	The options are <b>S1</b> , a suspend state, where the computer is running in a low-power mode, and <b>S3</b> , a standby state, where the power is reduced or turned off for most components, however, system memory remains active.
AC Power Recovery	Determines what happens when AC power is restored to the computer.
Low Power Mode	When <b>Low Power Mode</b> is selected, remote wakeup events no longer power up from <b>Hibernate</b> or <b>Off</b> .
<b>System Security</b>	
Password Status	This option locks the system password field with the setup password. When the field is locked, the option to disable password security by pressing <Ctrl><Enter> when the computer starts is no longer available.
System Password	Displays the current status of the system's password security feature as <b>Enabled</b> or <b>Disabled</b> .
Setup Password	Displays the current status of the system's password security feature and allows a new system password to be assigned and verified.
PXE BIS Default Policy	Used to set the NIC On w/PCE feature policy to <b>Deny</b> , <b>Accept</b> , or <b>Reset</b> . See <a href="#">Network Interface Controller</a> .

## Boot Sequence

This feature allows you to change the boot sequence for devices.

## Option Settings

- **Diskette Drive** — The computer attempts to boot from the floppy drive. If the floppy disk in the drive is not bootable, if no floppy disk is in the drive, or if there is no floppy drive installed in the computer, the computer generates an error message.
- **Hard Drive** — The computer attempts to boot from the primary hard drive. If no operating system is on the drive, the computer generates an error message.
- **CD Drive** — The computer attempts to boot from the CD drive. If no CD is in the drive, or if the CD has no operating system, the computer generates an error message.
- **USB Flash Device** — Insert the memory device into a USB port and restart the computer. When F12 = Boot Menu appears in the upper-right corner of the screen, press <F12>. The BIOS detects the device and adds the USB flash option to the boot menu.



**NOTE:** To boot to a USB device, the device must be bootable. To make sure your device is bootable, check the device documentation.

## Changing Boot Sequence for the Current Boot

You can use this feature, for example, to restart your computer to a USB device such as a floppy drive, memory key, or CD-RW drive.

 **NOTE:** If you are booting to a USB floppy drive, you must first set the floppy drive to OFF in [system setup](#).

1. If you are booting to a USB device, connect the USB device to a USB connector.
2. Turn on (or restart) your computer.
3. When F2 = Setup, F12 = Boot Menu appears in the upper-right corner of the screen, press <F12>.

If you wait too long and the operating system logo appears, continue to wait until you see the Microsoft Windows desktop. Then [shut down your computer](#) and try again.

The **Boot Device Menu** appears, listing all available boot devices. Each device has a number next to it.

4. At the bottom of the menu, enter the number of the device that is to be used for the current boot only.

For example, if you are booting to a USB memory key, highlight **USB Flash Device** and press <Enter>.

 **NOTE:** To boot to a USB device, the device must be bootable. To make sure that your device is bootable, check the device documentation.

## Changing Boot Sequence for Future Boots

1. [Enter system setup](#).
2. Use the arrow keys to highlight the **Boot Sequence** menu option and press <Enter> to access the menu.

 **NOTE:** Write down your current boot sequence in case you want to restore it.

3. Press the up- and down-arrow keys to move through the list of devices.
4. Press the spacebar to enable or disable a device (enabled devices have a check mark).
5. Press plus (+) or minus (-) to move a selected device up or down the list.

---

## Clearing Forgotten Passwords

 **CAUTION:** Before you begin any of the procedures in this section, follow the safety instructions located in the *Product Information Guide*.

1. Follow the procedures in [Before You Begin](#).



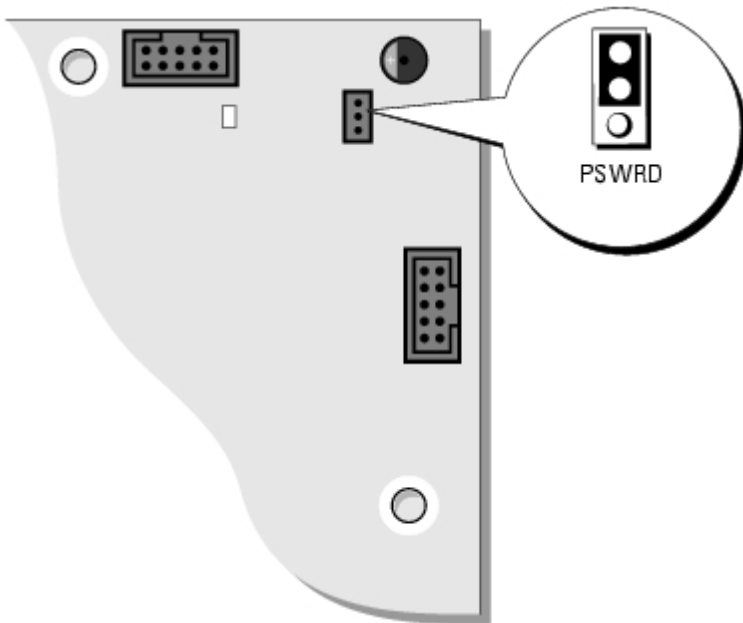

2. Locate the 3-pin password jumper (PSWRD) on the [system board](#) and attach the jumper plug to pins 2 and 3 to clear the password.

 **NOTE:** When you receive your computer, the jumper plug is attached to pins 1 and 2.

3. Close the computer cover.
4. Connect your computer and monitor to electrical outlets, and turn them on.
5. After the Microsoft Windows desktop appears on your computer, [shut down the computer](#).
6. Turn off the monitor and disconnect it from the electrical outlet.
7. Disconnect the computer power cable from the electrical outlet, and press the power button to ground the system board.
8. Open the computer cover.
9. Locate the 3-pin password jumper on the [system board](#) and attach the jumper to pins 1 and 2 to re- enable the password feature.
10. [Replace the computer cover](#).

 **NOTICE:** To connect a network cable, first plug the cable into the network wall jack and then plug it into the computer.

Connect your computer and devices to electrical outlets, and turn them on.

---

[Back to Contents Page](#)

# Removing and Installing Parts

## Dell™ Dimension™ 1100/B110 Systems Service Manual

- [Memory](#)
  - [Cards](#)
  - [Front Panel](#)
  - [Drives](#)
  - [Hard Drive](#)
  - [Floppy Drive](#)
  - [CD/DVD Drive](#)
  - [Processor](#)
  - [Fan Assembly](#)
  - [System Board](#)
  - [Power Supply](#)
  - [Battery](#)
- 

## Memory

You can increase your computer memory by installing memory modules on the system board. For information on the type of memory supported by your computer, see [Technical Specifications](#).

 **NOTE:** DDR 333 memory operates at 320 MHz when used with an 800-MHz front-side bus.

## DDR Memory Overview

DDR memory modules should be installed in *pairs of matched memory size*. This means that if you purchased your computer with 128 MB of memory installed and you want to add another 128 MB of memory, you should install it in the appropriate connector. If the DDR memory modules are not installed in matched pairs, the computer will continue to operate, but with a slight reduction in performance.

 **NOTE:** Always install DDR memory modules in the order indicated on the system board.

 **NOTE:** Your computer has two memory slots labeled DIMM3 and DIMM4.

The recommended memory configurations are:

- Install a pair of matched memory modules in connectors DIMM3 and DIMM4.
- Do not install ECC memory modules.
- If you install a mixed pair PC2700 (DDR 333-MHz) and PC3200 (DDR 400-MHz) memory, the modules function at the slowest speed installed.
- Be sure to install a single memory module in DIMM3 or the connector closest to the processor before you install modules in the other connector.

## Memory Installation Guidelines

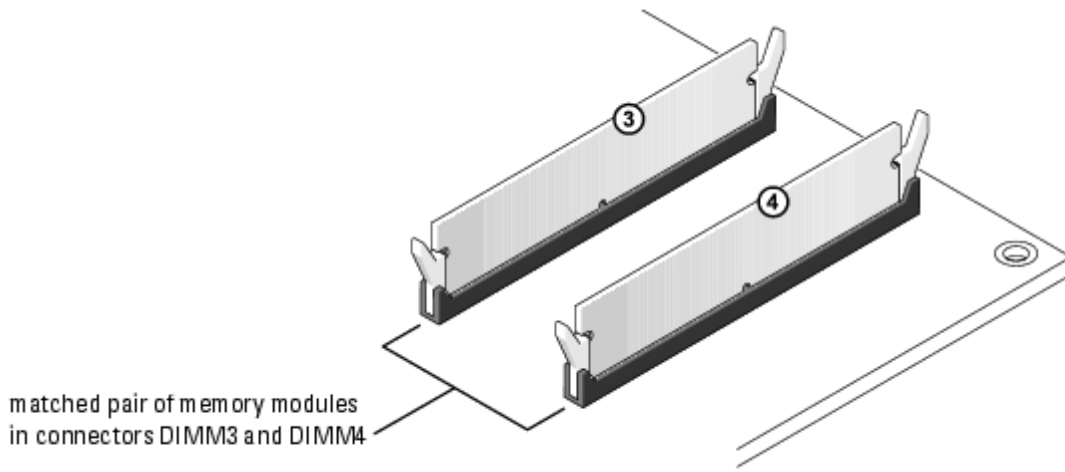

➡ **NOTICE:** If you remove your original memory modules from the computer during a memory upgrade, keep them separate from any new modules that you may have, even if you purchased the new modules from Dell. You should install your new memory modules in connectors DIMM3 and DIMM4. If possible, *do not* pair an original memory module with a new memory module. Otherwise, your computer may not function at optimal performance.

🔧 **NOTE:** Memory purchased from Dell is covered under your computer warranty.

## Installing Memory

⚠ **CAUTION:** Before you begin any of the procedures in this section, follow the safety instructions located in the *Product Information Guide*.

1. [Shut down the computer](#) through the **Start** menu
2. Ensure that your computer and attached devices are turned off. If your computer and attached devices did not automatically turn off when you shut down your computer, turn them off now.

➡ **NOTICE:** To disconnect a network cable, first unplug the cable from your computer and then unplug it from the network wall jack.

3. Disconnect any telephone or telecommunication lines from the computer.
4. Disconnect your computer and all attached devices from their electrical outlets, and then press the power button to ground the system board.

⚠ **CAUTION:** To guard against electrical shock, always unplug your computer from the electrical outlet before opening the cover.

5. Remove the computer cover.
6. Lay the computer on its side so that the system board is on the bottom of the inside of the computer.
7. If necessary, remove a memory module:
  - a. Press out the securing clip at each end of the memory module connector.
  - b. Grasp the module and pull up.

If the module is difficult to remove, gently ease the module back and forth to remove it from the connector.

8. To insert a module, press out the securing clip at each end of the memory module connector.

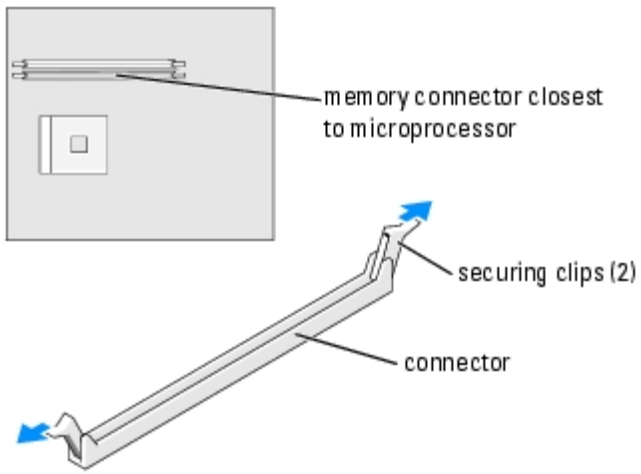

9. Align the notch on the bottom of the module with the crossbar in the connector.

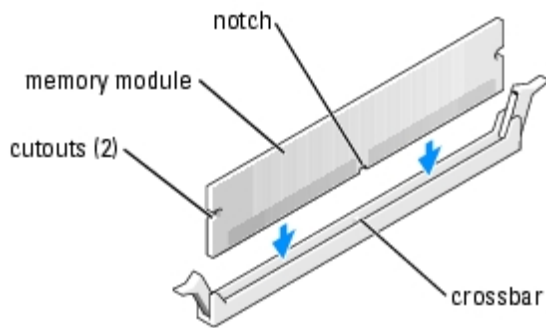

**NOTICE:** To avoid breaking the memory module, do not press near the middle of the module.

10. Insert the module straight down into the connector, ensuring that it fits into the vertical guides at each end of the connector. Press firmly on the ends of the module until it snaps into place.

If you insert the module correctly, the securing clips snap into the cutouts at each end of the module.

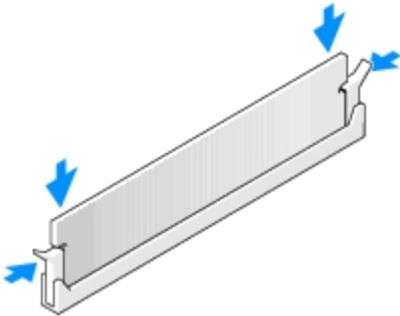

11. [Replace the computer cover.](#)

**NOTICE:** To connect a network cable, first plug the cable into the network wall jack and then plug it into the computer.

12. Connect your computer and devices to electrical outlets, and then turn them on.

13. Click the **Start** button, right-click **My Computer**, and then click **Properties**.

14. Click the **General** tab.

15. To verify that the memory is installed correctly, check the amount of memory (RAM) listed.
- 

## Cards

- CAUTION:** Before you begin any of the procedures in this section, follow the safety instructions located in the *Product Information Guide*.
- NOTICE:** To prevent static damage to components inside your computer, discharge static electricity from your body before you touch any of your computer's electronic components. You can do so by touching an unpainted metal surface on the computer chassis.

Your computer provides three slots for PCI cards.

## PCI Cards



If you are installing or replacing a card, follow the procedures in the next section. If you are removing, but not replacing a card, see [Removing a PCI Card](#).

If you are replacing a card, remove the current driver for the card from the operating system.

## Installing a PCI Card

1. Follow the procedures in [Before Your Begin](#).
2. Unscrew and remove the filler bracket for the card slot you want to use.

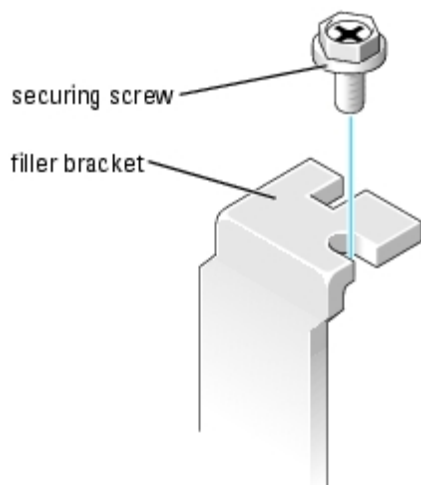

- CAUTION:** Some network adapters automatically start the computer when they are connected to a network. To guard against electrical shock, be sure to unplug your computer from its electrical outlet

**before installing any cards.**

3. Align the cutout on the bottom of the card with the crossbar in the system board connector. Gently rock the card into the connector until it is fully seated.

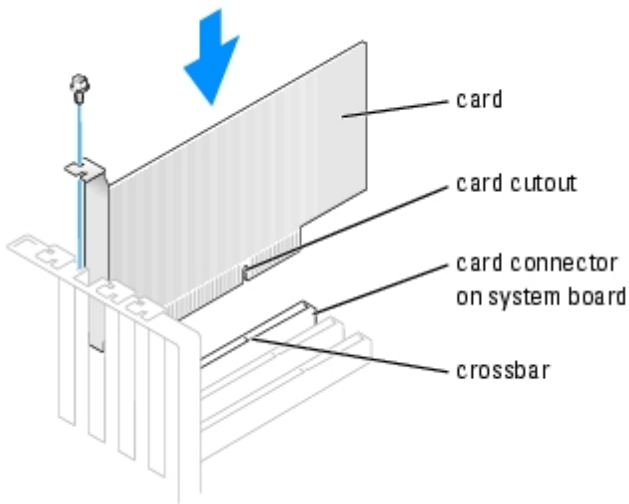

Ensure that the card is fully seated and that its bracket is within the card slot.

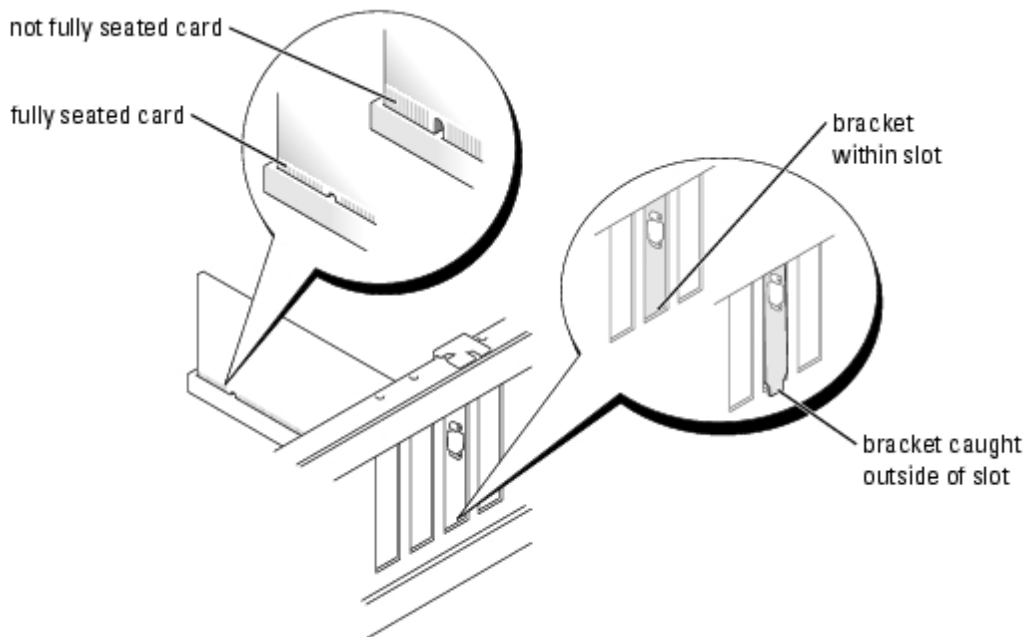

4. Secure the card bracket with the screw you removed in [step 2](#).
5. Connect any cables that should be attached to the card.

For information about the card's cable connections, see the documentation for the card.

**NOTICE:** Do not route card cables over or behind the cards. Cables routed over the cards can cause damage to the equipment.

6. If you installed a sound card:
  - a. [Enter system setup](#), select **Audio Controller**, and then change the setting to **Off**.
  - b. Connect external audio devices to the sound card's connectors. Do not connect external audio devices to the

microphone, speaker/headphone, or line-in connectors on the back panel.

7. If you installed an add-in network adapter and want to disable the integrated network adapter:
  - a. Enter system setup, select **Network Controller**, and then change the setting to **Off**.
  - b. Connect the network cable to the add-in network adapter's connectors. Do not connect the network cable to the integrated connector on the back panel.
8. Install any drivers required for the card as described in the card documentation.

## Removing a PCI Card

1. Follow the procedures in [Before You Begin](#).
2. If necessary, disconnect any cables connected to the card.
3. Remove the securing screw from the card bracket.
4. Grasp the card by its top corners, and ease it out of its connector.
5. If you are removing the card permanently, install a filler bracket in the empty card-slot opening.

If you need a filler bracket, see "Contacting Dell" in your *Owner's Manual* for instructions on obtaining technical assistance.



**NOTE:** Installing filler brackets over empty card-slot openings is necessary to maintain FCC certification of the computer. The brackets also keep dust and dirt out of your computer.



**NOTICE:** To connect a network cable, first plug the cable into the network wall jack and then plug it into the computer.

6. Close the computer cover, reconnect the computer and devices to electrical outlets, and then turn them on.
7. Remove the card's driver from the operating system.
8. If you removed a sound card:
  - a. [Enter system setup](#), select **Audio Controller**, and then change the setting to **On**.
  - b. Connect external audio devices to the audio connectors on the computer back panel.
9. If you removed an add-in network connector:
  - a. [Enter system setup](#), select **Network Controller**, and then change the setting to **On**.
  - b. Connect the network cable to the integrated connector on the computer back panel.

---

## Front Panel



**CAUTION:** Before you begin any of the procedures in this section, follow the safety instructions located in the *Product Information Guide*.



**CAUTION:** To guard against electrical shock, always unplug your computer from the electrical outlet before opening the cover.

## Removing the Front Panel

1. Follow the procedures in [Before You Begin](#).

2. [Remove the computer cover.](#)

3. Release and remove the front panel:

- a. If your computer has a release lever, push the release lever to release the top tab.
- b. Reach inside the computer and push the top and bottom tab towards you to release them.
- c. Rotate the front panel to separate it from the side hinges.

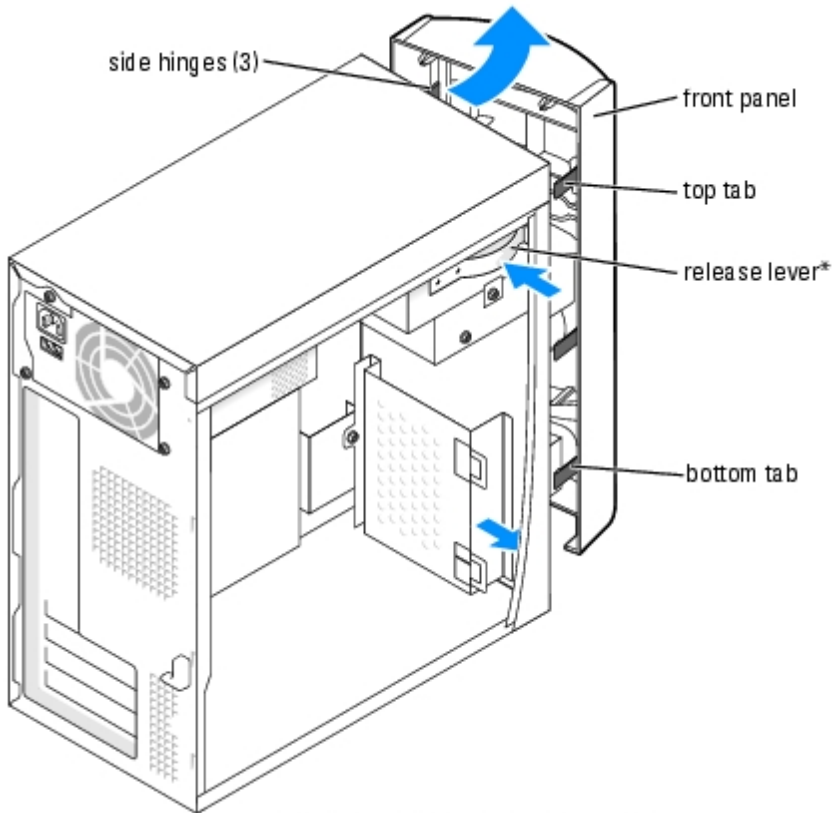

\*May not be present on all computers.

## Removing the Front-Panel Insert

1. Press in the two insert tabs.



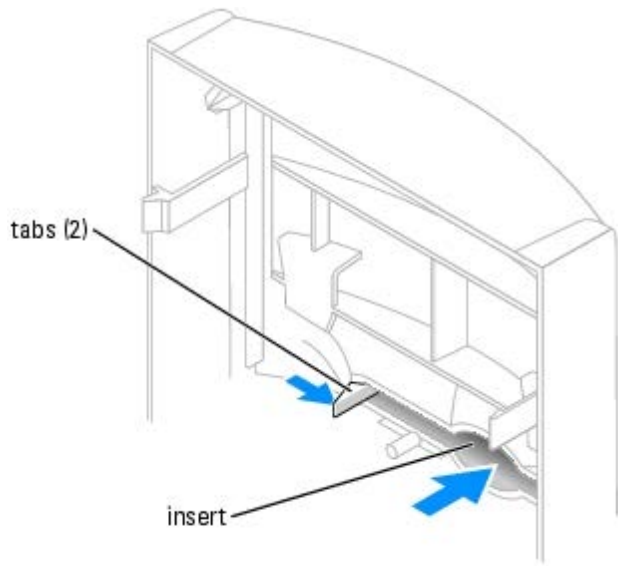

2. Push out the front-panel insert.

## Reattaching the Front Panel

1. Reattach the front panel to the side hinges.

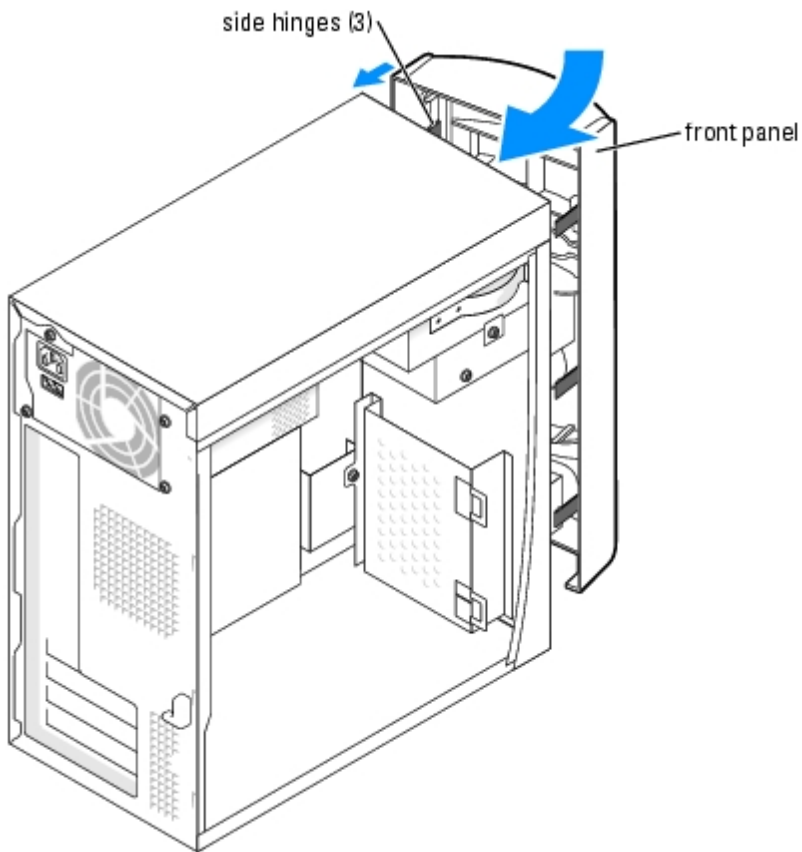

2. Rotate the front panel until it snaps onto the front of the computer.
-

# Drives

Your computer supports a combination of these devices:

- One hard drive
- One optional floppy
- Up to two CD or DVD drives

## General Installation Guidelines

Connect the IDE hard drive to the system board connector labeled PRI IDE. Connect CD/DVD drives to the connector labeled J6J1.

When you connect two IDE devices to a single IDE interface cable and configure them for the cable select setting, the device attached to the last connector on the interface cable is primary or the boot device (drive 0), and the device attached to the middle connector on the interface cable is the secondary device (drive 1). See the drive documentation in your upgrade kit for information on configuring devices for the cable select setting.

## Connecting Drive Cables

When you install a drive, you connect two cables—a DC power cable and a data cable—to the back of the drive and to the system board. Some drives may also have an audio connector; one end of the audio cable will attach to the drive connector and the other will attach to the system board.

## Drive Interface Connectors

Most interface connectors are keyed for correct insertion; that is, a notch or a missing pin on one connector matches a tab or a filled-in hole on the other connector.

When connecting an IDE cable, ensure you align the colored stripe with the pin 1 connector. When disconnecting an IDE cable, grasp the colored pull tab and pull until the connector detaches.

## Power Cable Connector

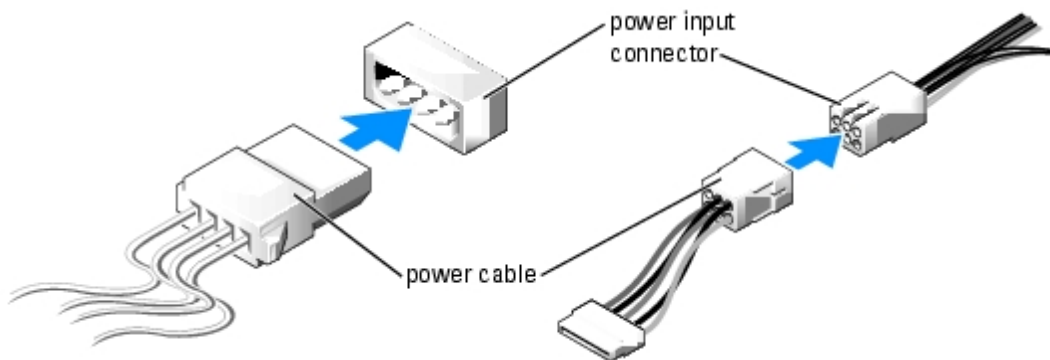

## Hard Drive

**⚠ CAUTION:** Before you begin any of the procedures in this section, follow the safety instructions located in the *Product Information Guide*.

**⚠ CAUTION:** To guard against electrical shock, always unplug your computer from the electrical outlet before opening the cover.

**➡ NOTICE:** To avoid damage to the drive, do not set it on a hard surface. Instead, set the drive on a surface, such as a foam pad, that will sufficiently cushion it.

1. If you are replacing a hard drive that contains data you want to keep, back up your files before you begin this procedure.
2. Follow the procedures in [Before You Begin](#).
3. Remove the computer cover (see [Removing the Computer Cover](#)).

## Removing a Hard Drive

1. Disconnect the power and data cables from the drive and from the system board.

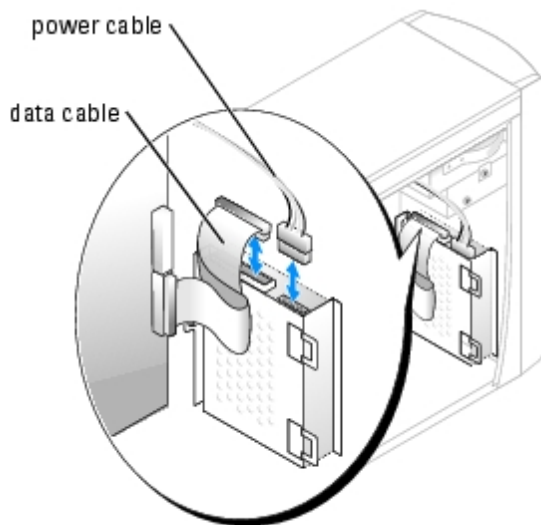

2. Remove the hard drive bracket from the computer:
  - a. Remove the two screws securing the bracket to the computer.
  - b. Rotate the bracket so that the bracket tabs can be disengaged from the computer.
  - c. Remove the bracket containing the hard drive from the computer.

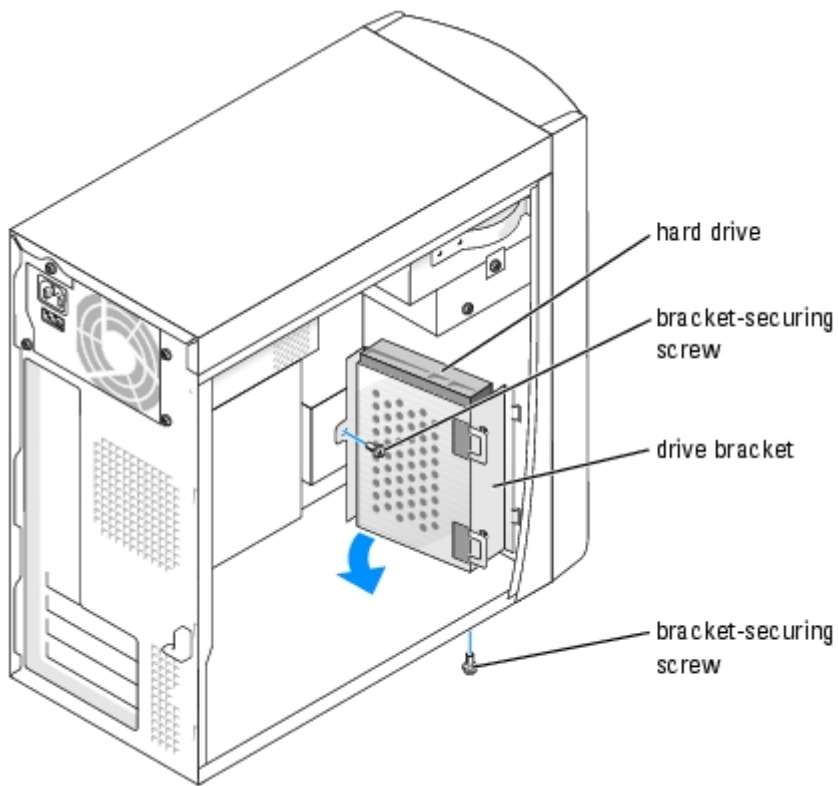

3. If you are replacing the hard drive, remove the drive from the bracket:

- a. Remove the hard drive-securing screws.
- b. Remove the hard drive from the bracket.

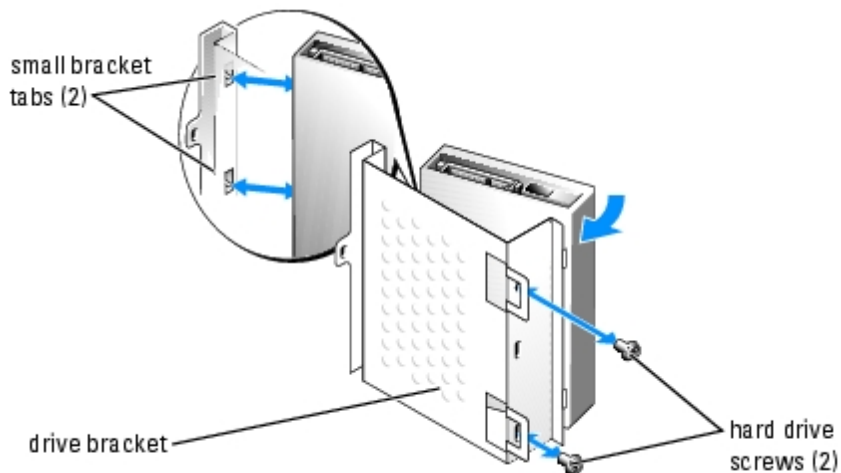

## Installing a Hard Drive

1. Unpack the replacement hard drive, and prepare it for installation.
2. Check the documentation for the drive to verify that it is configured for your computer.
3. Remove the hard drive bracket (see [page 50](#)).
4. Attach the hard drive to the hard drive bracket:
  - a. Place the small bracket tabs into the drive screw holes on one side of the drive.

- b. Gently swing the drive toward the bracket and align the two screw holes on the other side of the drive with the screw holes on the bracket.
    - c. Insert and tighten the two screws that secures the hard drive to the hard drive bracket.
  5. Install the hard drive bracket containing the hard drive:
    - a. Insert the two bracket tabs into the two bracket securing slots inside the computer.
    - b. Rotate the bracket toward the front panel and align the bracket screw hole with the screw hole in the chassis.
    - c. Replace the two screws that secure the bracket to the computer.

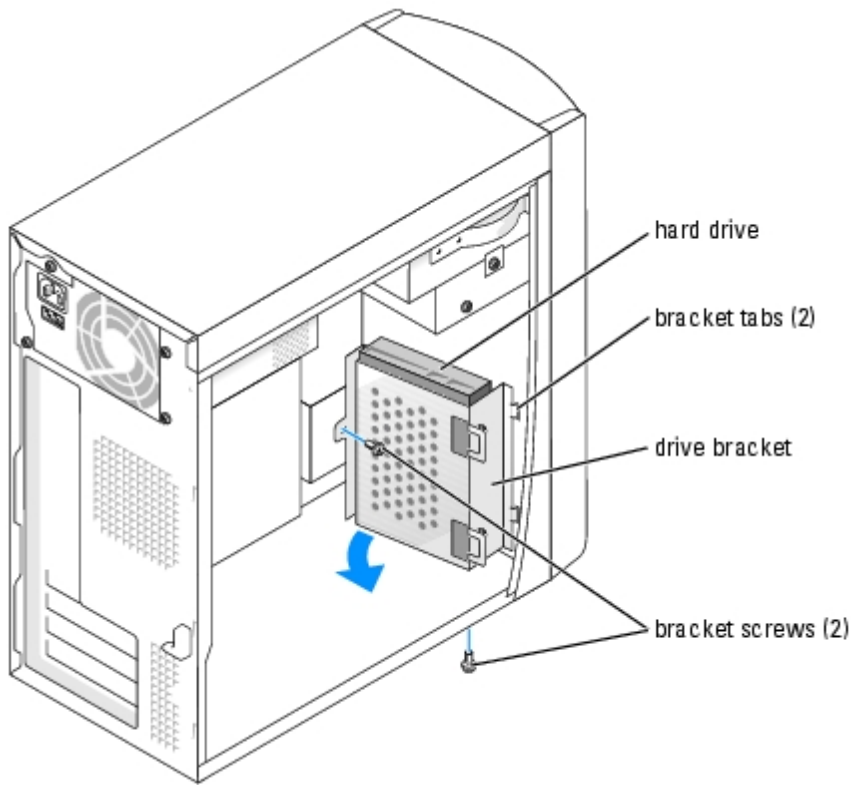

6. Connect a power cable to the drive.
        7. Connect the data cable to the drive and to the system board (see [System Board Components](#)).
        8. Close the computer cover (see [Replacing the Computer Cover](#)).

**NOTICE:** To connect a network cable, first plug the cable into the network wall jack and then plug it into the computer.

9. Connect your computer and devices to electrical outlets, and turn them on.

See the documentation that came with the drive for instructions on installing any software required for drive operation.

10. If the drive you just installed is the primary drive, insert a bootable floppy disk into drive A.
        11. Turn on the computer.
        12. Enter system setup (see [System Setup](#)), and update the appropriate **Drive** option.
        13. Exit system setup, and restart the computer.
        14. Partition and logically format your drive before you proceed to the next step.

See the documentation for your operating system for instructions.

15. Test the hard drive by running the Dell Diagnostics.

If the drive you just installed is the primary drive, install your operating system on the hard drive.

---

## Floppy Drive

**⚠ CAUTION:** Before you begin any of the procedures in this section, follow the safety instructions located in the *Product Information Guide*.

**⚠ CAUTION:** To guard against electrical shock, always unplug your computer from the electrical outlet before opening the cover.

1. Follow the procedures in [Before You Begin](#).
2. Release and remove the front panel (see [page 46](#)).

**🔧 NOTE:** If you are adding a floppy drive, see [Installing a Floppy Drive](#).

## Removing a Floppy Drive

1. Disconnect the power and data cables from the back of the floppy drive and from the system board (see [System Board Components](#)).

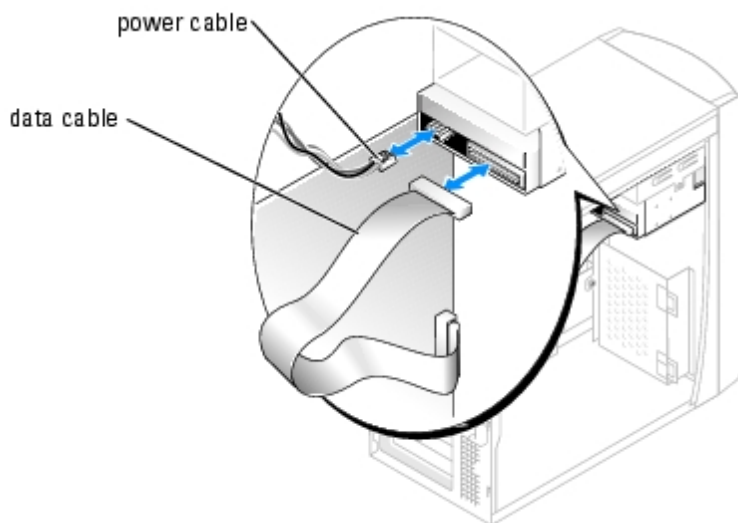

2. Remove the floppy drive bracket from the computer:
  - a. Remove the bracket-securing screw for the floppy drive.
  - b. Remove the bracket for the floppy drive from the computer.

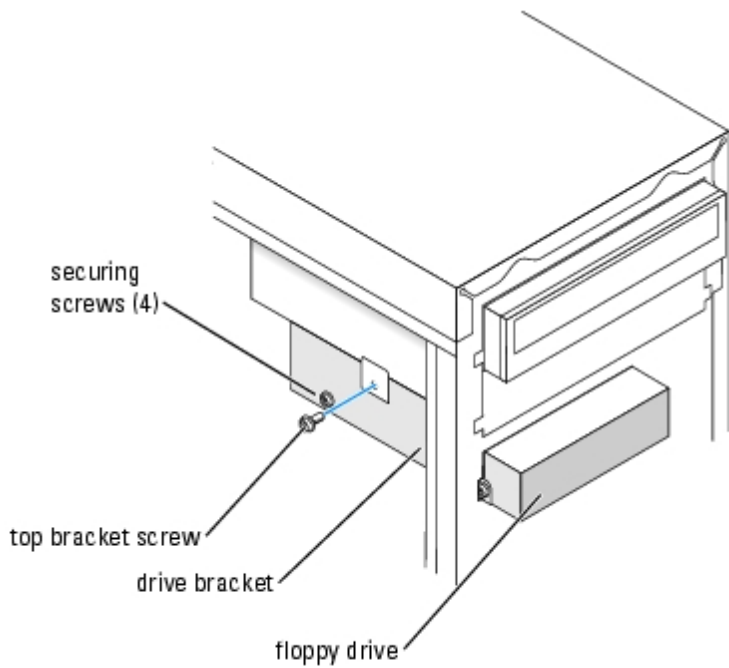

3. Remove the floppy drive from the bracket:
  - a. Remove all four drive-securing screws (two on each side).
  - b. Remove the floppy drive from the bracket.

## Installing a Floppy Drive

1. Remove the floppy drive bracket from the computer (see [page 55](#)).
2. If you are replacing a floppy drive, remove the drive from the bracket (see [page 55](#)).
3. Attach the floppy drive bracket to the floppy drive:
  - a. Align the screw holes on the drive with the screw holes on the bracket.
  - b. Insert and tighten all four drive-securing screws (two on each side).
4. Position the top of the floppy drive bracket so that it is completely flush with the bottom of the upper drive bay, and then slide the floppy drive bracket forward into position.

 **NOTE:** The top of the floppy drive bracket has two slots that fit into two clips on the bottom of the upper drive bay. When the floppy drive bracket is properly mounted, it remains in place without support.

5. Secure the floppy drive bracket with the top bracket screw that came with your drive.
6. Reattach the front panel (see [page 48](#)).
7. Connect the data cable to the back of the drive and to the floppy drive connector on the system board (see [page 12](#)).

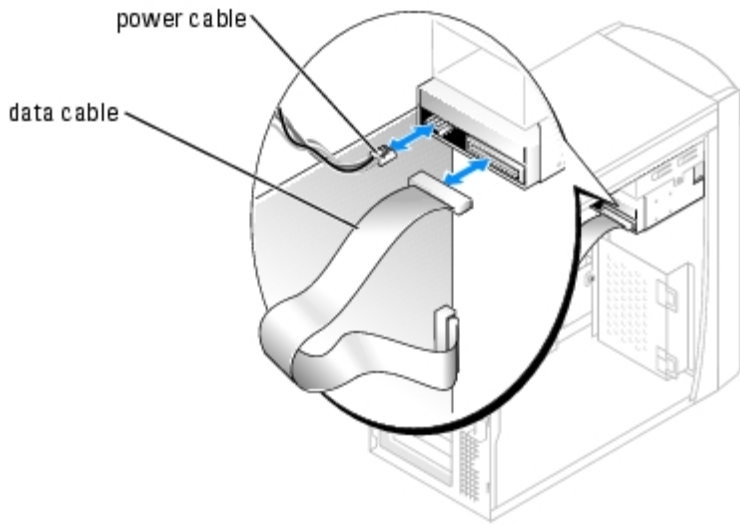

➡ **NOTICE:** Match the colored strip on the cable with pin 1 on the drive (pin 1 is marked as "1").

8. Reattach the front panel (see [page 48](#)).
9. Replace the computer cover (see [Replacing the Computer Cover](#)).

➡ **NOTICE:** To connect a network cable, first plug the cable in to the network wall jack and then plug it in to the computer.

10. Connect your computer and devices to their electrical outlets, and turn them on.

See the documentation that came with the drive for instructions on installing any software required for drive operation.

11. Enter system setup (see [Entering System Setup](#)) and update the appropriate **Diskette Drive** option.
12. Verify that your computer works correctly by running the Dell Diagnostics.

---

## CD/DVD Drive

⚠ **CAUTION:** Before you begin any of the procedures in this section, follow the safety instructions located in the *Product Information Guide*.

⚠ **CAUTION:** To guard against electrical shock, always unplug your computer from the electrical outlet before opening the cover.

1. Follow the procedures in [Before You Begin](#).
2. Remove the computer cover (see [Removing the Computer Cover](#)).
3. Release and remove the front panel (see [page 46](#)).

## Removing a CD/DVD Drive

1. Disconnect the power, audio, and CD/DVD drive cables from the back of the drive and from the system board.



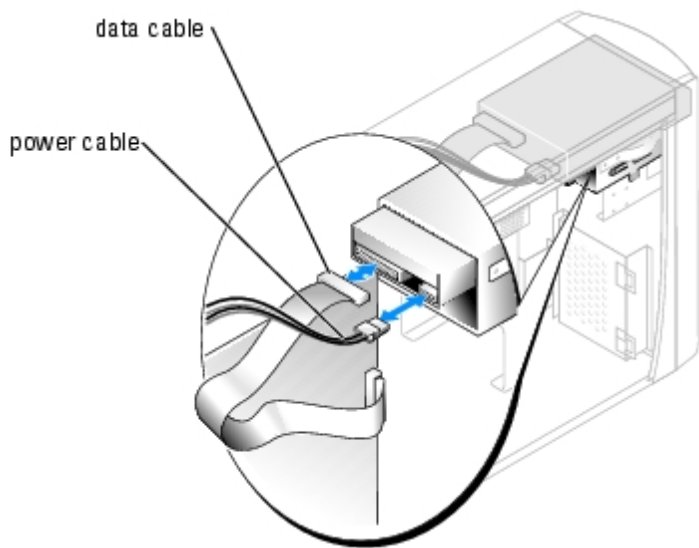

2. Remove the CD/DVD drive securing screw.
3. Slide the drive forward and remove it from the drive bay.

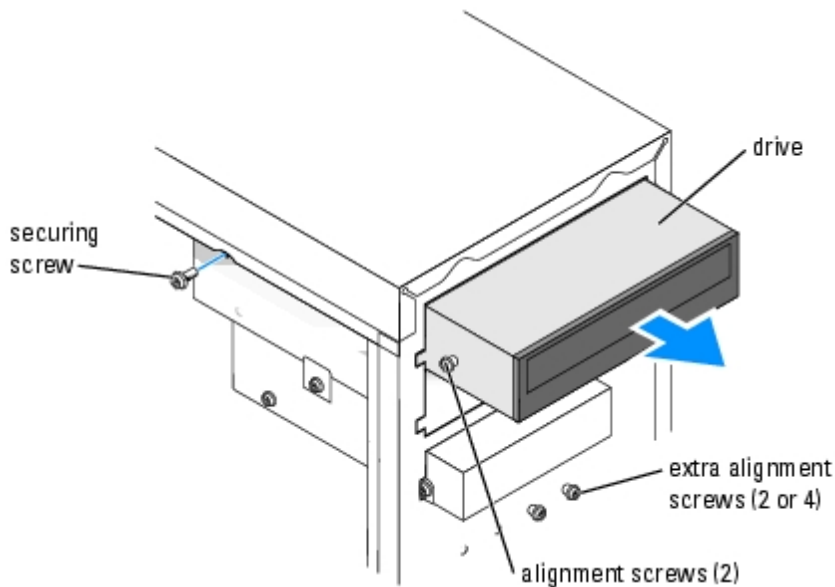

## Installing a CD/DVD Drive

1. If you are installing a new drive, unpack the drive and prepare it for installation.

Check the documentation that accompanied the drive to verify that the drive is configured for your computer. If you are installing an IDE drive, configure the drive for the cable select setting.

2. If you are replacing a drive, remove the existing drive (see [page 57](#)).
3. Gently slide the drive into place in the drive bay.
4. After the drive is in place, apply pressure to ensure that the drive is fully seated.
5. Use the securing screw that came with the drive to attach the drive to the computer.

**NOTICE:** Match the colored strip on the cable with pin 1 on the drive (pin 1 is marked as "1").

6. Connect the power cable to the system board (see [System Board Components](#)).
7. Connect the power and CD/DVD drive cables to the drive and to the system board (see [System Board Components](#)).
8. If you are installing a drive that has its own controller card, install the controller card in a card slot.
9. Reattach the front panel (see [page 48](#)).
10. Replace the computer cover (see [Replacing the Computer Cover](#)).

 **NOTICE:** To connect a network cable, first plug the cable in to the network wall jack and then plug it into the computer.

11. Connect your computer and devices to their electrical outlets, and turn them on.

See the documentation that came with the drive for instructions on installing any software required for drive operation.

12. Enter system setup (see [Entering System Setup](#)) and select the appropriate **Drive** option.
13. Verify that your computer works correctly by running Dell Diagnostics.

## Adding a Second CD or DVD Drive

1. Ensure that the jumper setting on the new drive is set for "cable select" (see the documentation that came with the drive for information).
2. Remove two extra alignment screws, shown in the illustration on [page 59](#), from the front of the computer and insert them into the drive.

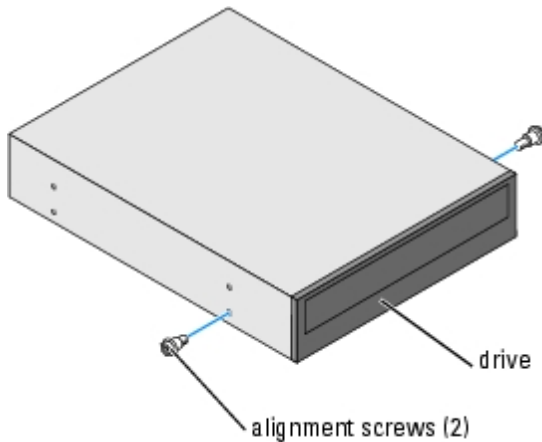

 **NOTE:** Some computers come with only two extra alignment screws; others come with four. You only need two alignment screws for this procedure.

3. Gently slide the drive into place in the drive bay.

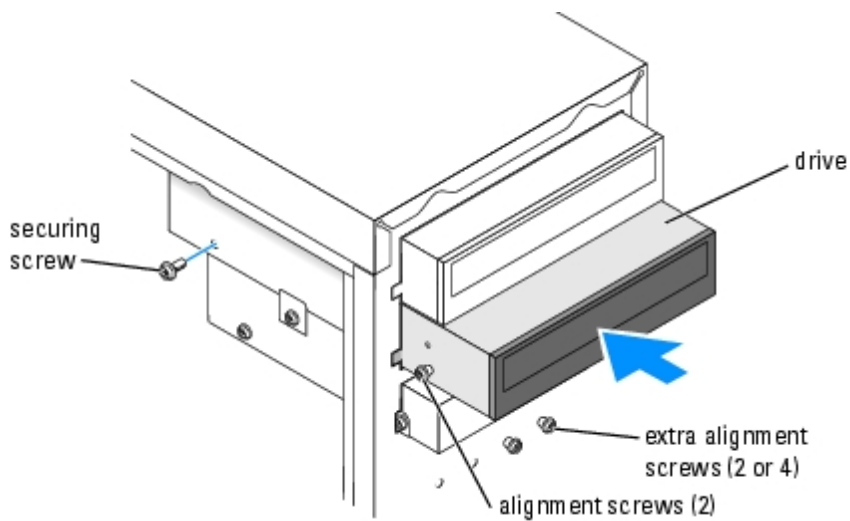

4. After the drive is in place, apply pressure to ensure that the drive is fully seated.
5. Use the securing screw that came with the drive to attach the drive to the computer.

➡ **NOTICE:** Match the colored strip on the cable with pin 1 on the drive (pin 1 is marked as "1").

6. Connect the power cable to the system board (see [System Board Components](#)).
7. Locate the data cable from the CD or DVD drive in the upper drive bay and connect its middle data connector to the new drive.

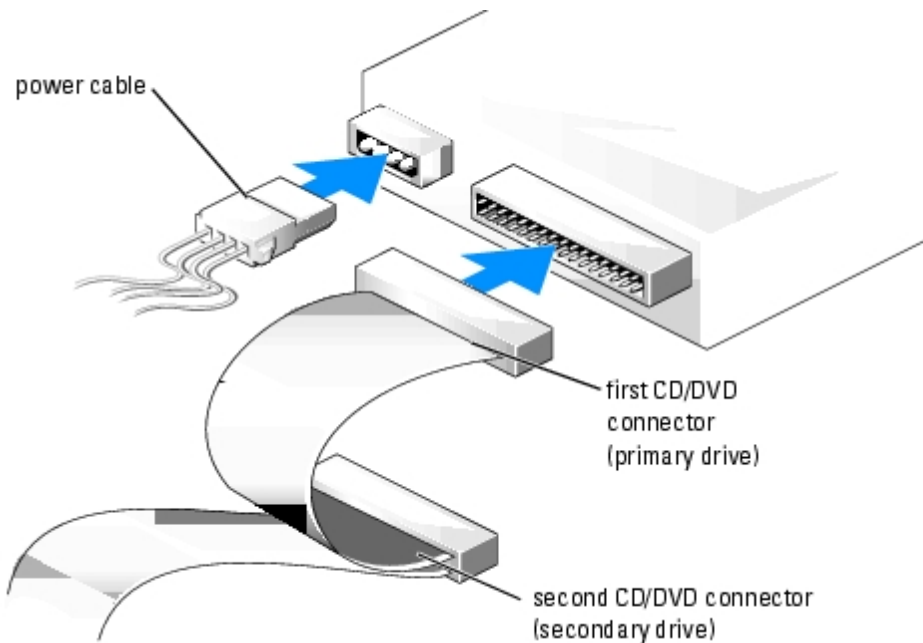

8. Reattach the front panel (see [page 48](#)).
9. Replace the computer cover (see [Replacing the Computer Cover](#)).

➡ **NOTICE:** To connect a network cable, first plug the cable into the network wall jack and then plug it into the computer.

10. Connect your computer and devices to electrical outlets, and then turn them on.
11. See the documentation that came with the drive for instructions on installing any software required for drive operation.

---

# Processor

## Removing the Processor

**NOTICE:** Do not perform the following steps unless you are familiar with hardware removal and replacement. Performing these steps incorrectly could damage your system board. For technical service, see "Contacting Dell" in the *Owner's Manual*.

**CAUTION:** Before you begin any of the procedures in this section, follow the safety instructions located in the *Product Information Guide*.

1. Follow the procedures in [Before You Begin](#).
2. Disconnect the cooling fan power cable from the fan connector on the system board.
3. Disconnect the power cable from the processor power connector on the system board.
4. Lift up the airflow shroud.

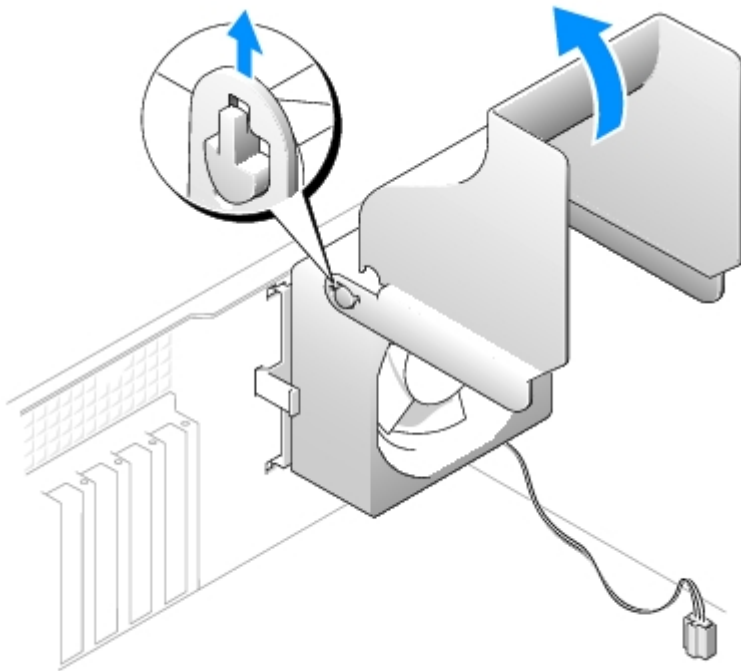

**CAUTION:** The heat sink can get very hot during normal operation. Be sure that the heat sink has had sufficient time to cool before you touch it.

5. Remove the microprocessor heat sink:
  - a. Twist the heat sink from side to side to break the seal.
  - b. Pull the release tab out until the heat sink is released.
  - c. Lift the heat sink away from the microprocessor.

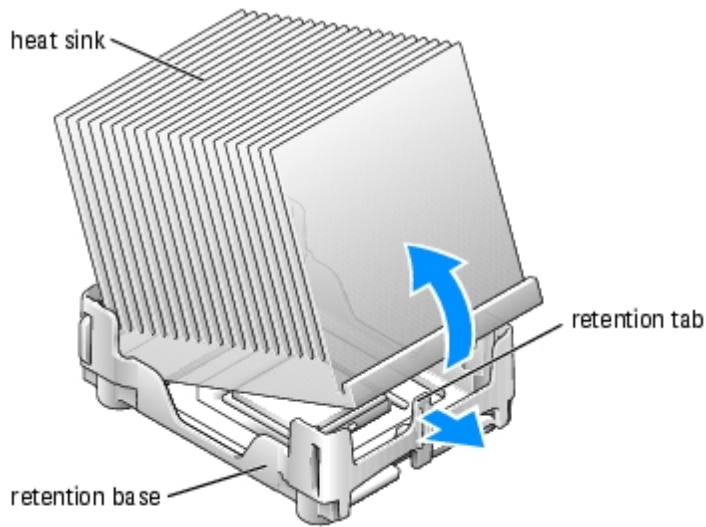

- d. On the retention base locate the tab opposite the power supply. Press on the retention base tab until the heat sink pops up slightly.
- e. Press out on the second retention tab while lifting the heat sink up and out of the retention base.

➡ **NOTICE:** Lay the heat sink down on its side.

➡ **NOTICE:** If you are installing a processor upgrade kit from Dell, discard the original heat sink. If you are *not* installing a processor upgrade kit from Dell, reuse the original heat sink and blower when you install your new processor.

6. Push down and out on the socket release lever.
7. Open the processor cover.

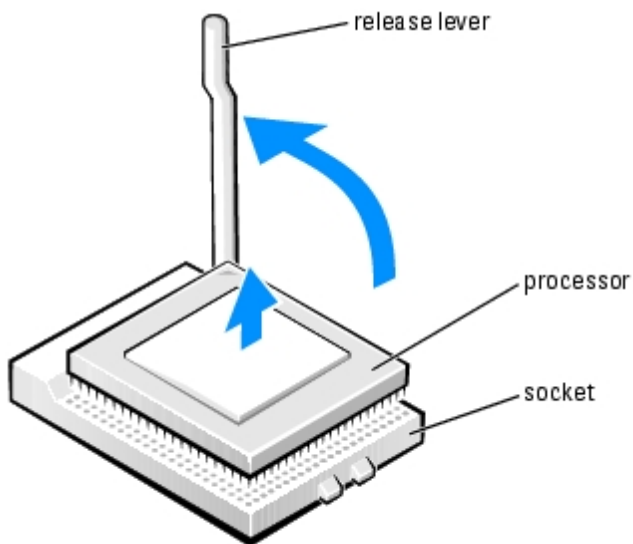

8. To remove the processor from the socket, lift the processor vertically in one motion.

Leave the release lever extended in the release position so that the socket is ready for the new processor.

## Installing the Processor

➔ **NOTICE:** Ground yourself by touching an unpainted metal surface on the back of the computer.

1. Unpack the new processor.

➔ **NOTICE:** You must position the processor correctly in the socket to avoid permanent damage to the processor and the computer when you turn on the computer.

2. If the release lever on the socket is not fully extended, move it to that position.
3. Align the pin-1 corners of the processor and socket.

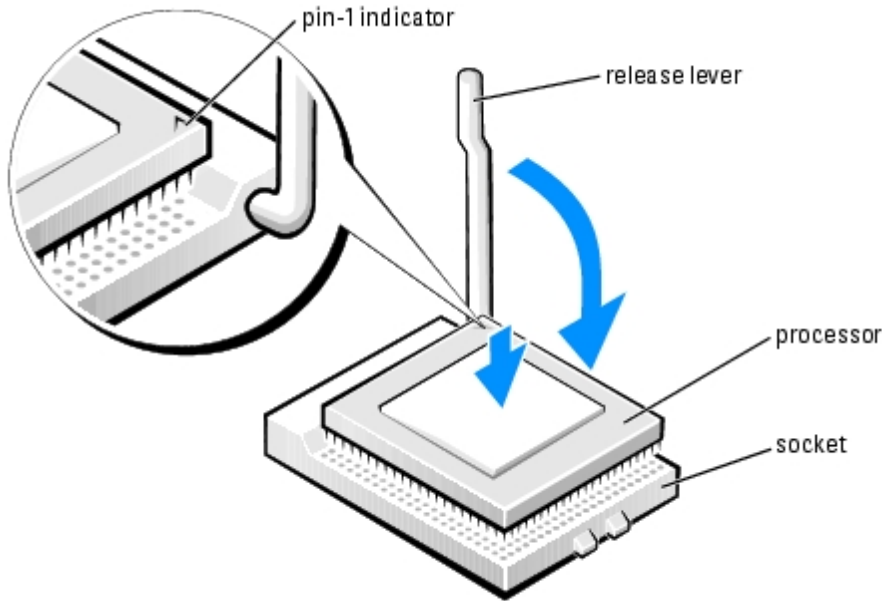

➔ **NOTICE:** Socket pins are delicate. To avoid damage, ensure that the processor is aligned properly with the socket, and do not use excessive force when you install the process. Be careful not to touch or bend the pins on the system board.

4. Set the processor lightly in the socket and ensure that the processor is level in the socket. When the processor is positioned correctly, press it with minimal pressure to seat it.
5. When the processor is fully seated in the socket, close the processor cover.
6. Pivot the socket release lever back toward the socket and snap it into place to secure the processor.

➔ **NOTICE:** If you are *not* installing a processor upgrade kit from Dell, reuse the original heat sink assembly when you replace the processor.

If you installed a processor replacement kit from Dell, return the original heat sink assembly and processor to Dell in the same package in which your replacement kit was sent.

7. Install the heat sink:
  - a. Slide one end of the heat sink under the retention tab.
  - b. Lower the heat sink until it fits securely in the module.

➔ **NOTICE:** Ensure the heat sink is correctly seated and secure.

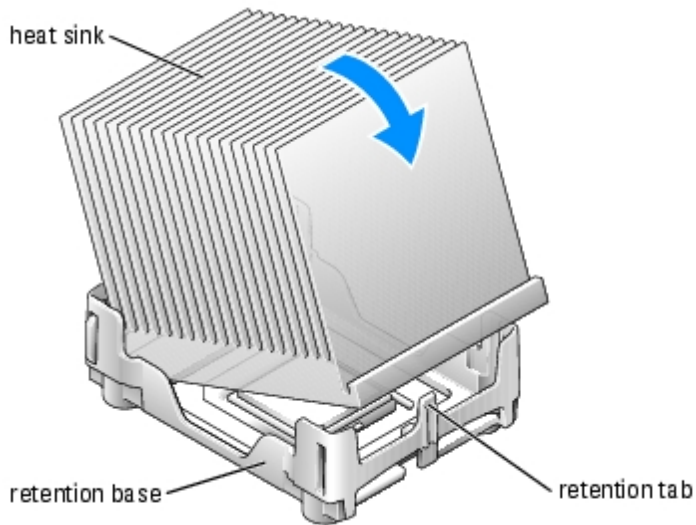

8. Lower the airflow shroud over the heat sink.
9. Reconnect the cooling fan power cable to the fan connector on the system board.
10. Reconnect the power cable to the processor power connector on the system board.
11. Close the computer cover.



 **NOTICE:** To connect a network cable, first plug the cable into the network wall jack and then plug it into the computer.

12. Connect your computer and devices to electrical outlets, and turn them on.

---

## Fan Assembly

### Removing the Fan Assembly

-  **CAUTION:** Before you begin any of the procedures in this section, follow the safety instructions located in the *Product Information Guide*.
-  **CAUTION:** To guard against electrical shock, always unplug your computer from the electrical outlet before removing the cover.

1. Follow the procedures in [Before You Begin](#).
2. Disconnect the AC power cable from the AC power connector on the back of the power supply.
3. Unplug the DC power cables from the drives and system board.
4. Lift up the airflow shroud.

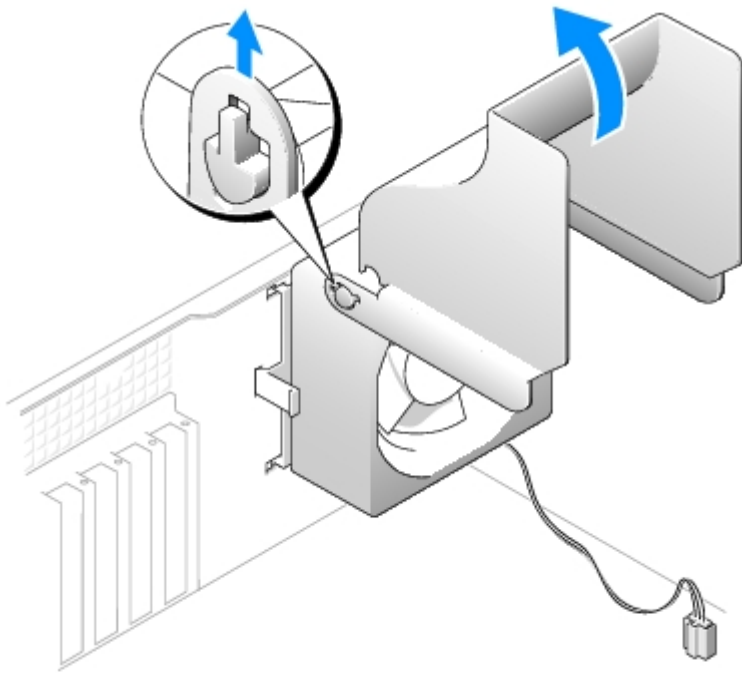

5. Disconnect the fan power cable from its connector on the system board.
6. Pull the fan release lever away from the back of the computer and slide the fan toward the release lever.

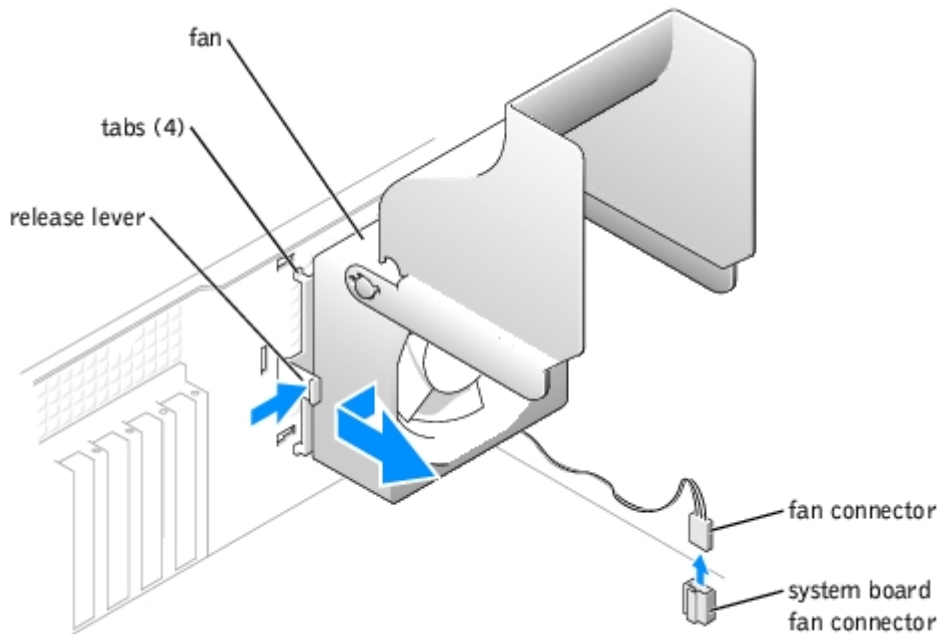

7. Remove the fan assembly from the computer.

## Replacing the Fan Assembly

1. Align the fan assembly tabs with the holes in the back of the computer.
2. Slide the fan assembly away from the fan release lever until it clicks in place.
3. Reconnect the DC power cables to the drives and system board.



4. Replace the computer cover.
5. Connect the AC power cable to the AC power connector on the back of the power supply.

 **NOTICE:** To connect a network cable, first plug the cable into the network wall jack and then plug it into the computer.

6. Connect your computer and devices to electrical outlets, and turn them on.
- 

## System Board

### Removing the System Board

 **CAUTION:** Before you begin any of the procedures in this section, follow the safety instructions in the *Product Information Guide*.

 **CAUTION:** To guard against electrical shock, always unplug your computer from the electrical outlet before removing the cover.

1. Follow the procedures in [Before You Begin](#).
2. Remove the floppy drive.
3. Remove any cards that are installed.
4. Disconnect all cables from the [system board](#).
5. Lift up the heat-sink shroud.

 **CAUTION:** The microprocessor heat sink can get hot. To avoid burns, ensure that the heat sink has had sufficient time to cool before you touch it.

6. [Remove the microprocessor heat sink](#).
7. [Remove the fan assembly](#).
8. Remove the 6 screws that secure the system board to the computer frame.

Two of the 6 screws that secure the system board to the computer frame are located on either side of the DIMM 1 memory slot connector..

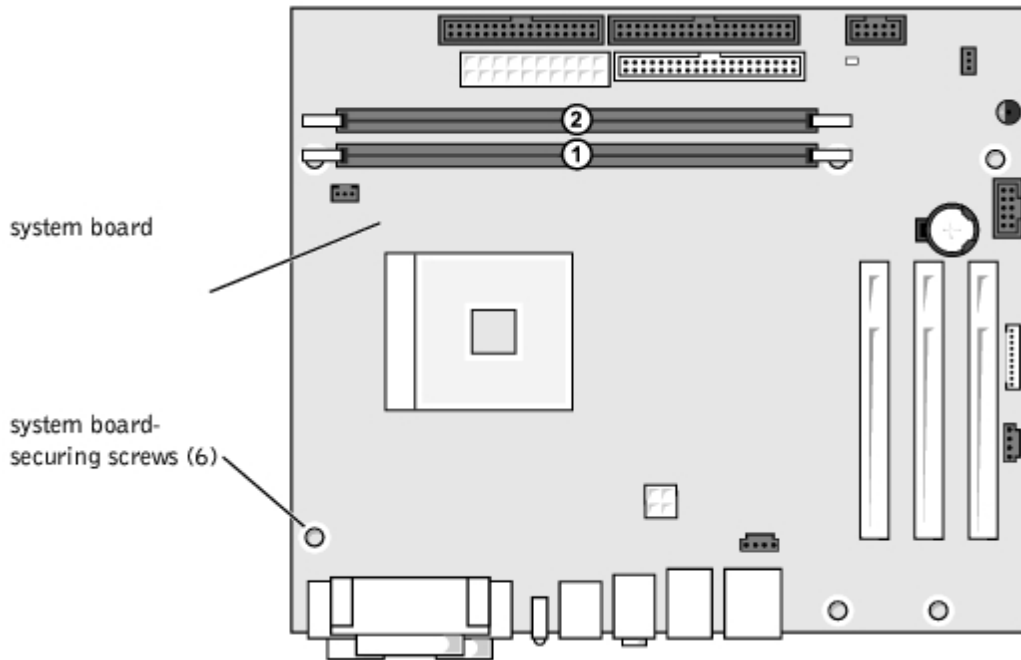

9. Lift the system board out from the computer.
10. Place the system board that you just removed next to the replacement system board.

Visually compare the replacement system board to the existing system board to ensure that you have the correct part.

## Installing the System Board

1. Transfer components from the existing system board to the replacement system board:
  - a. Remove the memory modules and install them on the replacement board.

**⚠ CAUTION:** The microprocessor package can get hot. To avoid burns, ensure that the package has had sufficient time to cool before you touch it.

- b. [Remove the microprocessor](#) package from the existing system board and transfer it to the replacement system board.
2. Configure the settings of the replacement system board.

Set the jumpers on the replacement system board so that they are identical to the ones on the existing board.

3. Place the system board inside the computer frame, place the heat-sink base on the system board, and then replace the screws that you removed in [step 8](#) of the preceding procedure.
4. [Reinstall the fan assembly](#).
5. Reinstall the microprocessor heat sink, and then lower the heat-sink shroud.
6. Reattach the cables to the system board.
7. Reinstall any cards.
8. Replace the floppy drive.
9. Replace the computer cover.

➡ **NOTICE:** To connect a network cable, first plug the cable into the network wall jack and then plug it into the computer.

10. Connect your computer and devices to electrical outlets, and turn them on.

---

## Power Supply

### Removing the Power Supply

- ⚠ **CAUTION:** Before you begin any of the procedures in this section, follow the safety instructions in the *Product Information Guide*.
- ⚠ **CAUTION:** To guard against electrical shock, always unplug your computer from the electrical outlet before removing the cover.

1. Follow the procedures in [Before You Begin](#).
2. [Remove the fan assembly](#).
3. Disconnect the AC power cable from the AC power connector on the back of the power supply.
4. Unplug the DC power cables from the drives and system board.
5. Remove the four screws that secure the power supply to the back of the computer.

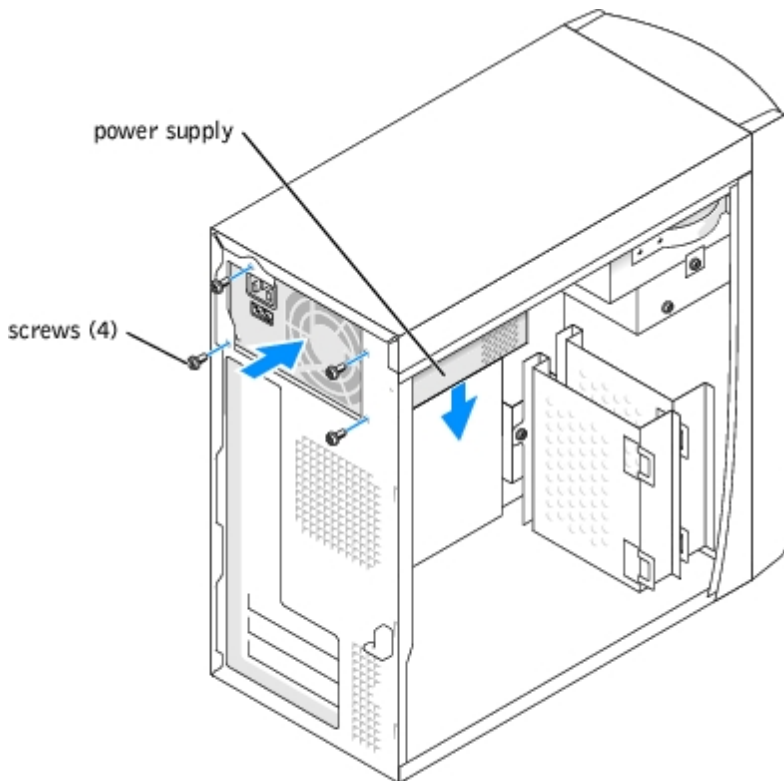

6. Remove the power supply from the computer.

### Replacing the Power Supply

1. Slide the power supply into place.
2. Replace the four screws that secure the power supply to the back of the computer.
3. [Reinstall the fan assembly](#).
4. Reconnect the DC power cables to the drives and system board.
5. Replace the computer cover.
6. Connect the AC power cable to the AC power connector on the back of the power supply.

 **NOTICE:** To connect a network cable, first plug the cable into the network wall jack and then plug it into the computer.

7. Connect your computer and devices to electrical outlets, and turn them on.
- 

## Battery

 **CAUTION:** Before you begin any of the procedures in this section, follow the safety instructions located in the *Product Information Guide*.

 **NOTICE:** To prevent static damage to components inside your computer, discharge static electricity from your body before you touch any of your computer's electronic components. You can do so by touching an unpainted metal surface on the computer chassis.

A coin-cell battery maintains computer configuration, date, and time information. The battery can last several years.

If you have to repeatedly reset time and date information after turning on the computer, replace the battery.

 **CAUTION:** A new battery can explode if it is incorrectly installed. Replace the battery only with the same or equivalent type recommended by the manufacturer. Discard used batteries according to the manufacturer's instructions.

To replace the battery:

1. Record all the screens in [system setup](#) so that you can restore the correct settings in [step 8](#).
2. Follow the procedures in [Before You Begin](#).
3. Locate the battery socket on the [system board](#).

 **NOTICE:** If you pry the battery out of its socket with a blunt object, be careful not to touch the system board with the object. Ensure that the object is inserted between the battery and the socket before you attempt to pry out the battery. Otherwise, you may damage the system board by prying off the socket or by breaking circuit traces on the system board.

4. Remove the battery by carefully prying it out of its socket with your fingers or with a blunt, nonconducting object such as a plastic screwdriver.
5. Insert the new battery into the socket with the side labeled "+" facing up, and snap the battery into place.

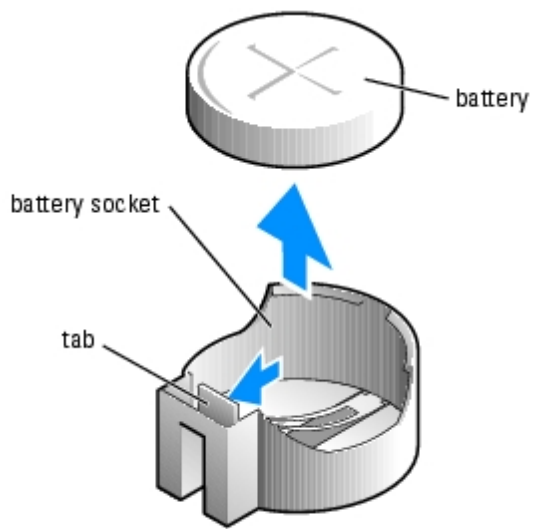

6. [Replace the computer cover.](#)

➡ **NOTICE:** To connect a network cable, first plug the cable into the network device and then plug it into the computer.

7. Connect your computer and devices to electrical outlets, and turn them on.

8. [Enter system setup](#) and restore the settings you recorded in step 1.

9. Properly dispose of the old battery (see the "Battery Disposal" section of your *Product Information Guide*).

---

[Back to Contents Page](#)

# Replacing the Computer Cover

## Dell™ Dimension™ 1100/B110 Systems Service Manual

 **CAUTION:** Before you begin any of the procedures in this section, follow the safety instructions located in the *Product Information Guide*.

1. Ensure that all cables are connected, and fold cables out of the way.

Gently pull the power cables toward you so that they do not get caught underneath the drives.

2. Ensure that no tools or extra parts are left inside the computer.
3. Place the cover on the computer.
4. Slide the cover towards the front of the computer until it fits completely into place.

 **NOTICE:** To connect a network cable, first plug the cable into the network wall jack and then plug it into the computer.

5. Connect your computer and devices to electrical outlets, and turn them on.