

# Microstepping Driver

## 2M982

### Introduction

2M982 is a constant torque microstepping driver, voltage range from 24-80V, it's suitable for various 2-phase NEMA23 & NEMA34 hybrid stepper motor with 7.8A peak current. With the build-in the constant current chopping circuit, the motor run stable without vibration and noise in low speed. When there is no pulse input within 100m/s, the current automatically reduced to be 50%.

### Features

- 20-80V DC power supply
- H bridge bi-polar constant current resolution driver
- 2-64 Microstep resolution with 16 different micro steps
- Over-current, over-voltage, over temperature and short-circuit protection
- EAN protection

### Electric Specifications

Description	Min.	Typical	Max.	Unit
Peak Output Current	1.3	-	7.8	Amps
Supply voltage	+24	+48	+80	VDC
Logic signal current	-	10	-	mA
Pulse input frequency	0	-	200	Khz
Pulse low level time	2.5	-	-	μs

### Environment

Cooling	Natural cooling or forced wind cooling	
Environment	Space	Avoid dust, oil fog & corrosive gases
	Storage temperature	-10°C - 80°C
	Working temperature	65°C Max
	Humidity	<80%RH
Vibration		5.9m/s <sup>2</sup> Max
Weight		0.54 kgs

**Setting current and microstepping**

SW1, SW2, SW3 used for setting current

SW4 use for half and full current, ON / full current, OFF/ half current

SW5, SW6, SW7, SW8 used for setting microstepping

OFF=0, ON=1

*Current setting:*

RMS current	Peak current	SW1	SW2	SW3
1.3A	1.8A	0	0	0
1.8A	2.5A	1	0	0
2.5A	3.5A	0	1	0
3.1A	4.3A	1	1	0
3.7A	5.2A	0	0	1
4.3A	6.0A	1	0	1
5.0A	7.0A	0	1	1
5.6A	7.8A	1	1	1

*Microstepping setting:*

Step/rev.(for 1.8°/motor)	SW5	SW6	SW7	SW8
200	0	0	0	0
400	1	0	0	0
500	0	1	0	0
800	1	1	0	0
1000	0	0	1	0
1200	1	0	1	0
1600	0	1	1	0
2000	1	1	1	0
2500	0	0	0	1
3200	1	0	0	1
4000	0	1	0	1
5000	1	1	0	1
6400	0	0	1	1
8000	1	0	1	1
10000	0	1	1	1

12800	1	1	1	1
-------	---	---	---	---

## Pin Assignment and Description

### P1 input signal

Signal	Function	Description
PLS+	input Opto-isolated positive	Connect +5V power supply, work with +5V - +24V, limited resistor needed when higher than +5V.
PLS-	Pulse signal	Effects with falling edge, motor runs one step when input pulse change from high to low, input resistance is 220 $\Omega$ , low level 0-0.5V, high level 4-5V, pulse width>2.5 $\mu$ s.
DIR+	input Opto-isolated positive	Connect +5V power supply, work with +5V - +24V, limited resistor needed when higher than +5V.
DIR-	Direction signal	Used to change motor running direction, input resistance is 220 $\Omega$ , low level 0-0.5V, high level 4-5V, pulse width>2.5 $\mu$ s.
ENA+	input Opto-isolated positive	Connect +5V power supply, work with +5V - +24V, limited resistor needed when higher than +5V.
ENA	Motor release signal	Low level, motor coil current cut off, driver stops work, and motor is not locked.

### P2 output signal

Signal	Function	Description
A+ A- B+ B-	Motor Connector	
+V	DC power	DC24-80.

GND	supply input	
-----	--------------	--

### Typical wiring

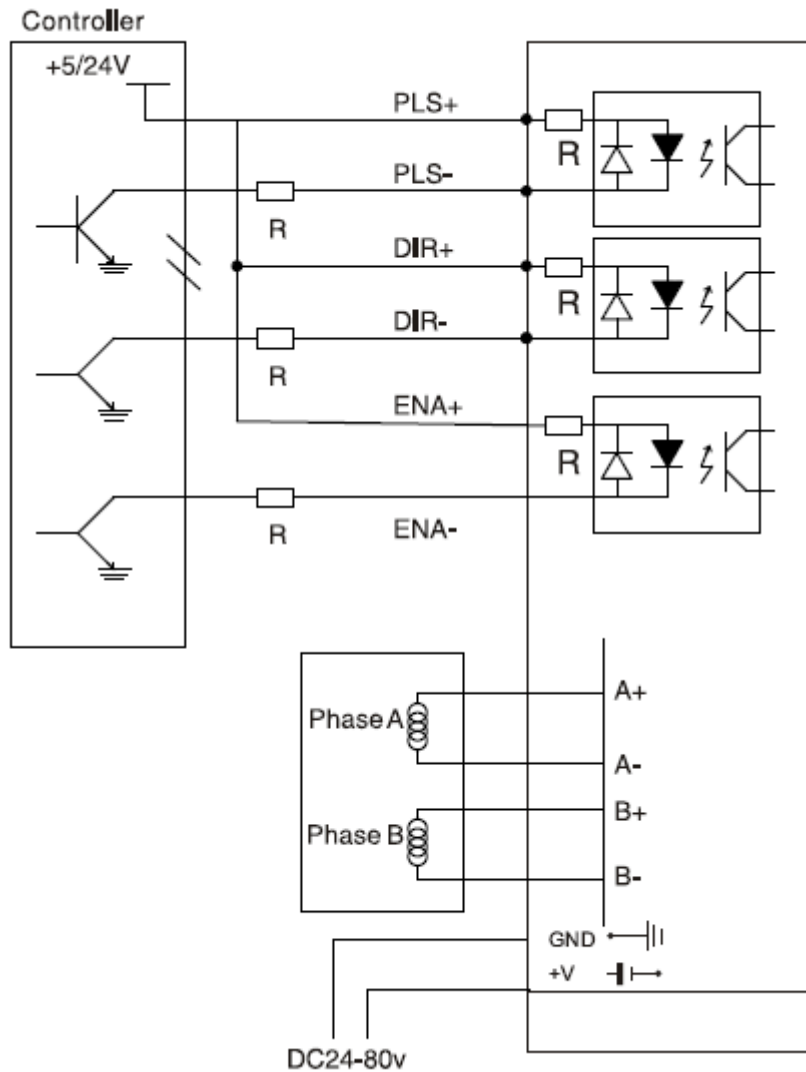

Note:

R=0 when Vcc is 5V

R=1K (power >1/8W) when Vcc is 12V

R=2K (power >1/8W) when Vcc is 24V

**Mechanical Size (in unit of mm)**

