



---

# JASD Series AC Servo Driver

## User Manual

**ADDRESS:**Floor2,Building A,Hongwei Industrial Zone  
No.6, Liuxian 3rd Road,Shenzhen.China  
**TEL:** 0755-26509689 26502268  
**Fax:** 0755-26509289  
**E- mail:**info@jmc-motion.com  
**Http:** //www.jmc-motion.com

## Preface

All contents of this manual, copyright owned by Shenzhen Just Motion Control Electromachics Co.,Ltd., shall not be arbitrarily reproduced, copied, transcribed without permission. This manual does not contain any forms of guarantee, standpoint statement, or hint. Shenzhen Just Motion Control and its employees will not take any responsibility for the loss caused by direct or indirect leaking information mentioned in this Manual. In addition, products information in this manual is for reference only, we are sorry for not offering update if it is improved.

All Copyright Reserved.

Shenzhen Just Motion Control Electromachics Co.,Ltd.

Version	Edited By	Proofreaded By
V1.0	Engineer Dept.	Engineer Dept.



## Content

Chaprel Safety Precautions.....	5
1.1 Installation.....	5
1.2 Connection.....	5
1.3 Operation.....	6
1.4 Maintenance & Inspection.....	6
Chapter2 Introduction.....	7
2.1 JASD Servo Drive.....	7
2.1.1 Outline.....	7
2.1.2 Main Features.....	7
2.1.3 Electrical Specifications.....	8
2.1.4 Model & Name Plate.....	9
2.2 JASM Servo Motor.....	10
2.2.1 Outline.....	10
2.2.2 Main Features.....	10
2.2.3 Model & Name Plate.....	11
Chapter3 Ports & Connection.....	12
3.1 Drive Ports.....	12
3.1.1 CN1 Port.....	12
3.1.2 CN2 Port & Connection.....	14
3.1.3 CN3 Port Definition.....	15
3.1.4 CN4 Port Definition.....	15
3.1.5 Power Supply & Motor Power Line Port.....	16
Chapter4 Installation instructions.....	17
4.1 Installation dimensions.....	17
4.2 Installation environment.....	20
Chapter5 Panel display and setting.....	21
5.1 Introduced function of panel.....	21
5.2 Operating mode switching process.....	21
5.3 Status display.....	22
5.4 Write and save method parameter Settings.....	23
Chapter6 control mode and setting.....	24
6.1 Position control.....	24
6.1.1 Position control wiring diagram.....	24
6.1.2 Position control command parameter.....	25
6.2 Speed control.....	26
6.2.1 Speed control wiring diagram.....	26
6.2.2 Speed control command parameters.....	27
6.3 Torque control.....	28
6.3.1 Torque control wiring diagram.....	28
6.3.2 The torque control command parameters.....	29
Chapter7 Trial Running.....	30
7.1 Inspection before running.....	30

7.2 Trial Running with no load.....	30
Chapter8 Parameter and Function.....	33
8.1 parameter.....	33
8.2 Parametric analysis.....	37
8.3 Monitoring projects list.....	48
8.4 Auxiliary function List.....	49
Chapter9 Fault Analysis and treatment.....	52
9.1 Failure alarm information list.....	52
9.2 Causes and Treatment of fault alarm.....	54

# Chapre1 Safety Precautions

The following explanations are for things that must be observed in order to prevent harm to people and damage to property, classified Specially below.

 Danger	Indicates great possibility of death or serious injury.
 Caution	Indicates possibility of injury or property damage..
	Indicates something that must not be done.

## 1.1 Installation

 Danger:

1. Please connect motor with drive according to assigned methods in case of damaging machine or fire.
2. Don't use at places with thick steam, combustibile, corrosive gas in case of electrical shocks, damages or fire etc.

## 1.2 Connection

 Danger:

1. Please don't connect drive power supply to motor output port U,V,W in case of damaging drive and even causing injury or fire.
2. Please confirm if power supply cable is connected with motor output connector, in case of fire caused by sparks.
3. Please select correct power cable and motor power extended cable to avoid fire caused by overcurrent.
4. Please be sure drive case and motor is connected to ground to avoid possible electric shock caused by imperfect earth.

 Caution:

1. Please don't bind motor power cable with signal cable, or pass through same tube in case of signal interference.
2. Please use multistrand shielding power cable, encoder feedback extended cable.
3. Please don't touch power supply connector, and confirm discharge indicator light is off before operate again. There is still high voltage inside after drive is powered off.
4. Please confirm all connection is correct before power on.

## 1.3 Operation

 Danger:

1. Please make no-load test before installation to avoid accident.
2. Please don't be operated by not trained personnel in case of injury or damage caused by misoperation.
3. Please don't touch heat sink or inside part of drive while running in case of burn or electric shock.

 Caution:

1. Please set drive parameters first, and then do long-term test in case of not working properly.
2. Please confirm switches like start, stop, turn off are enable to rerun.
3. Please don't turn on or off power supply frequently.

## 1.4 Maintenance & Inspection



1. Don't touch drive or motor inside while running in case of electric shock.
2. Don't touch power supply or wiring connector of power line in case of electric shock.
3. Don't change wires while power is on in case of electric shock or injury.
4. Operation and daily maintenance must be done by trained professionals.
5. Please don't disassembly or repair except JMC technicians.

## Chapter2 Introduction

### 2.1 JASD Servo Drive

#### 2.1.1 Outline

JASD series general servo drive is high performance AC servo unit researched by JMC. This series servo drive adopts advanced special DSP motor control chip, large-scale Field Programmable Gate Array(FPGA), and PIM power module, features small volume, high integration, stable performance, and reliable protection. Various digital values and analog I/O interfaces enable matching usage of various PC devices. It supports MODBUS communication protocol to facilitate networking as well, makes it possible to have all digital control of position, speed, and torque precision by optimized PID control algorithm, with the advantages of high precision, quick response, etc. Besides, this JASD servo drive can be matched with motors which are 2500 lines incremental encoder and 17 bits, 20 bits high precision absolute encoder to satisfy customers' various requirement of performance, widely applied in automation fields of numerical control machine tool, printing and packaging mechanism, textile machinery, robots, and automatic production line.

#### 2.1.2 Main Features

1. Excellent Position compensation function to have high precision positioning control.
2. With automatic gain control module, the user can choose according to demand response level.
3. The built-in FIR filter and the multiple sets of notch filter, can automatically recognize and suppress the mechanical vibration.
4. The built-in disturbance torque observer, makes the drive with a strong ability to resist external disturbance.
5. Three control modes. position control, speed control, torque control.
6. Location input pulse frequency up to 4 MHZ, support pulse + direction, orthogonal pulse, double pulse position command a variety of ways.
7. Programmable 8-way input and 5-way output port available, users can define input, output requirements via settings, flexible application.
8. Can be matched with motors which are 17 bits, 20 bits high precision absolute encoder.
9. Complete protection functions including overvoltage, undervoltage, overspeeding, overloading, Position deviation too large, encoder errors, etc.
10. Rich monitoring items, users can choose wanted items to test running state.
11. Drive communicates with PC via connecting RS232 port to have easy, quick debug servo drive system.

### 2.1.3 Electrical Specifications

#### (1) Single/3 phase 220V servo drive

Model JASD***2-20B	200	400	750	1000
Single Phase Continuous Input Current (A)	1.9	3.2	6.7	8.8
Continuous Output Current (A)	2.1	2.8	5.5	7.6
Max Output Current(A)	5.8	9.6	16.9	17
Main Circuit Power Supply	Single Phase AC180V-240V, 50/60HZ			
Control Circuit Power Supply	Single Phase AC180V-240V, 50/60HZ			
Rengen Resistor	no		Build-in	

#### (2) 3-phase 220V servo drive

Model JASD***2-20B	750	1000	1500	2000
Three Phase Continuous Input Current (A)	3.6	4.6	7.6	8.7
Continuous Output Current (A)	5.5	7.6	11.6	18.5
Max Output Current(A)	16.9	17	28	42
Main Circuit Power Supply	3-Phase AC180V-240V, 50/60HZ			
Control Circuit Power Supply	Single Phase AC180V-240V, 50/60HZ			
Rengen Resistor	Build-in			



## 2.1.4 Model & Name Plate

### 1、 Model Designation:

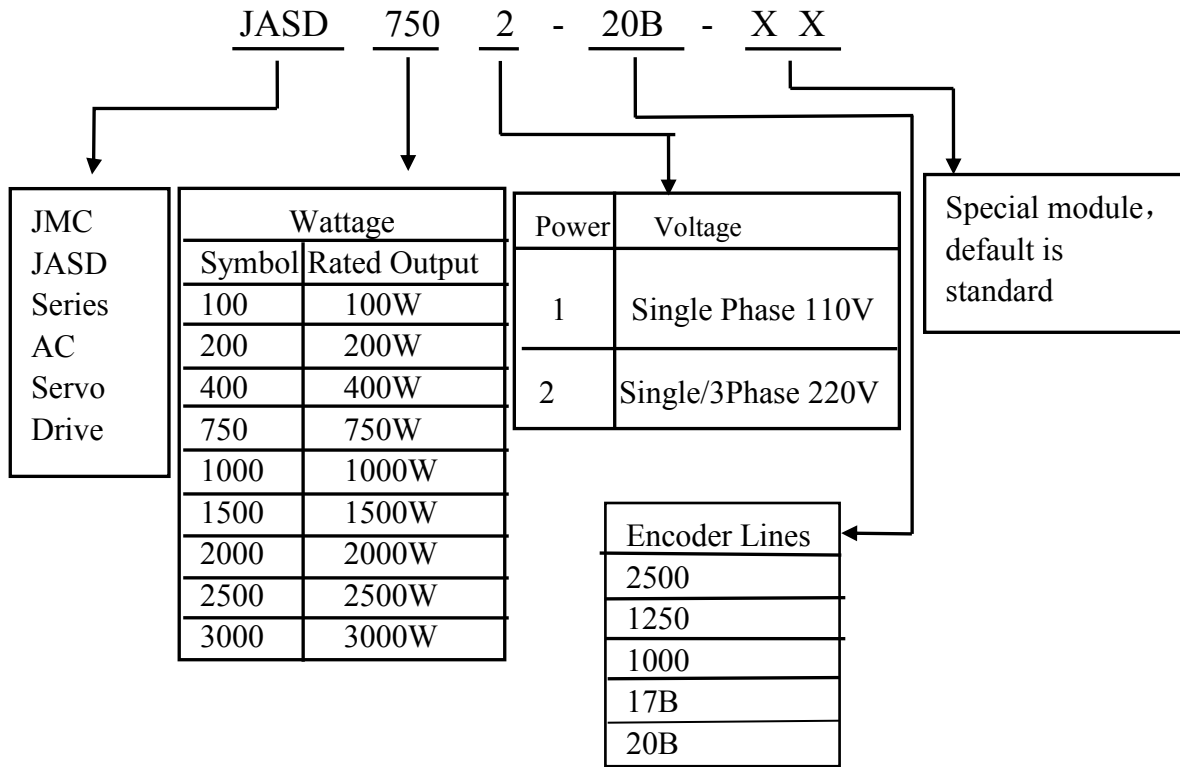

### 2、 Name Plate Designation:

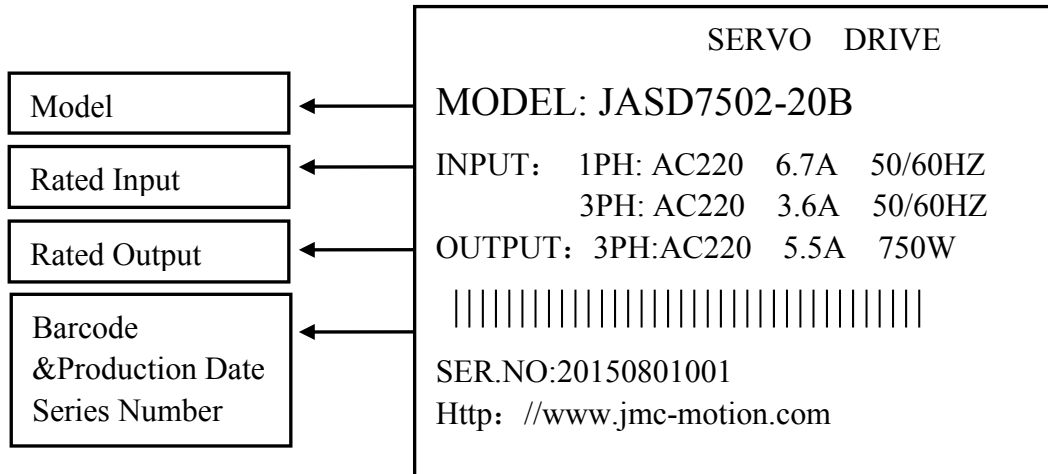

## 2.2 JASM Servo Motor

### 2.2.1 Outline

JASM series are high-speed, high-precision servo motors developed by Shenzhen Just Motion Control Electro mechanics Co. Ltd., designed to meet requirements of modern automatic motion control. This series motors make it possible to have excellent precise speed, position control, also can transform voltage signal to torque and speed to drive controlled members. The rotor of these servo motors is speed-controlled by input signal, quickly-responded. This series is used as executive component in automatic motion control system, features small electromechanical time constant, high linearity, and pick-up voltage, transform electrical signals to angular displacement or angular speed output, make high precision control by real-time feedback signals to have adjustment to servo drives.

### 2.2.2 Main Features

1. High energy magnetic
2. Short time 300% overload
3. Flange size(mm): 60、80、110、130
4. Wattage: 0.1-3KW available
5. Low noise, low heat, high precision, high speed etc.

### 2.2.3 Model & Name Plate

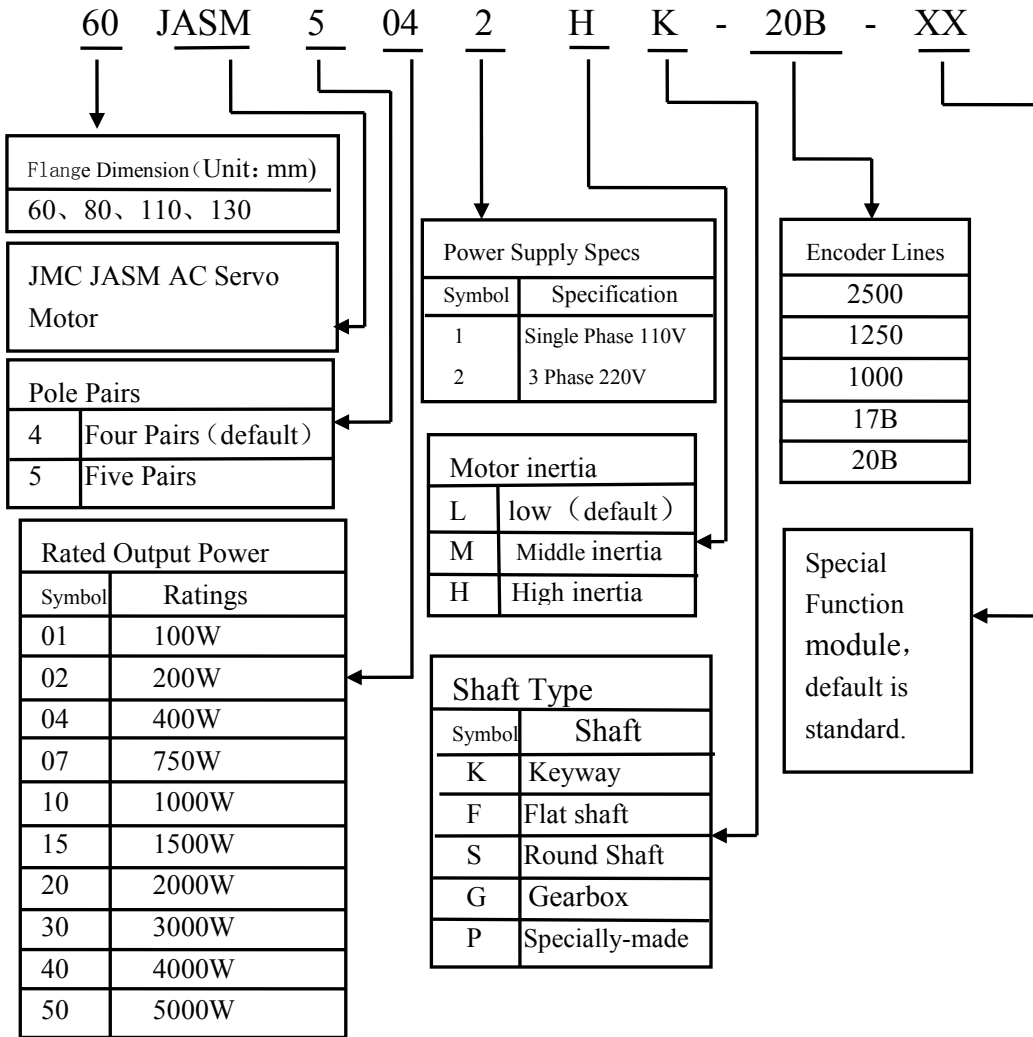

### 2、Name Plate Designation:

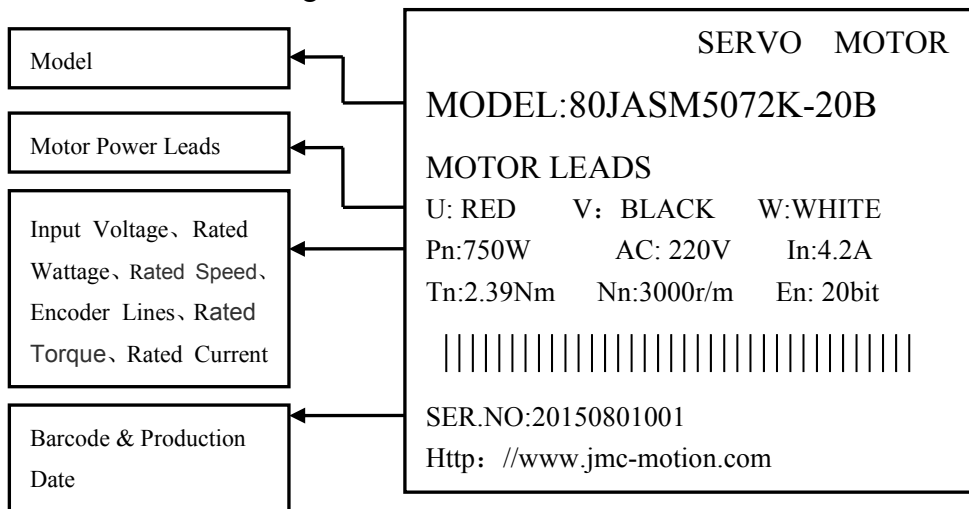

# Chapter3 Ports & Connection

## 3.1 Drive Ports

### 3.1.1 CN1 Port

The port that upper control connects with drive, is used for connection that upper PC controls drive, and drive feedbacks output.

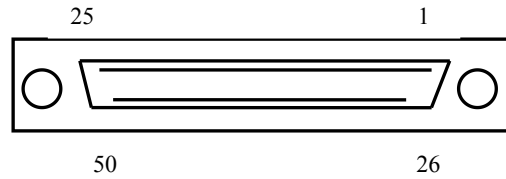

CN1 Port Specifics

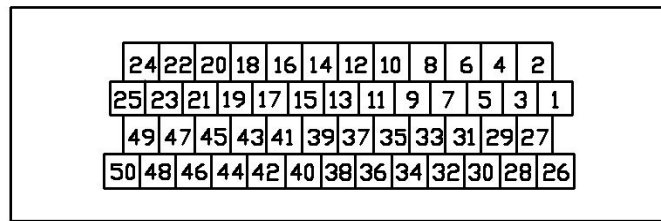

Map of SCSI-50P terminal pin in CN1 Port



SCSI-50P physical photo

CN1 terminal pins definition:

Pin NO.	Symbol	Name	Descriptions
1	DO4+	Digital Output 4 Positive	Custom Output Port
2	DO3-	Digital Output 3 Negative	Custom Output Port
3	DO3+	Digital Output 3 Positive	Custom Output Port
4	DO2-	Digital Output 2 Negative	Custom Output Port
5	DO2+	Digital Output 2 Positive	Custom Output Port
6	DO1-	Digital Output 1 Negative	Custom Output Port
7	DO1+	Digital Output 1 Positive	Custom Output Port
8	DI4-	Digital Input 4 Negative	Custom Input Port
9	DI1-	Digital Input 1 Negative	Custom Input Port
10	DI2-	Digital Input 2 Negative	Custom Input Port

11	COM+	Common Input Terminal	High Level 24V Input
12	GND A	Analog Ground	
13	GND A	Analog Ground	
14	NC	No Function	
15	MON2	Analog Data Monitor Output 2	
16	MON1	Analog Data Monitor Output 1	
17	+24V	+24V Output (For External I/O)	
18	T_REF	Torque Analog Command	
19	GND A	Analog Ground	
20	+12V	12V Output((For Analog command)	
21	OA+	Phase A Output Positive	
22	OA-	Phase A Output Negative	
23	OB-	Phase B Output Negative	
24	OZ-	Phase Z Output Negative	
25	OB+	Phase B Output Positive	
26	DO4-	Digital Output 4 Negative	Custom Output Port
27	DO5-	Digital Output 5 Negative	Custom Output Port
28	DO5+	Digital Output 5 Positive	Custom Output Port
29	HPUL-	High-speed Pulse Negative	
30	DI8-	Digital Input 8 Negative	Custom Input Port
31	DI7-	Digital Input 7 Negative	Custom Input Port
32	DI6-	Digital Input 6 Negative	Custom Input Port
33	DI5-	Digital Input 5 Negative	Custom Input Port
34	DI3-	Digital Input 3 Negative	Custom Input Port
35	24V SIGN+	24V Direction Positive	High Level 24V Input
36	SIGN+	Direction Positive	High Level 5V Input
37	SIGN-	Direction Negative	Low Level 0V Input
38	HPUL+	High-speed Pulse Positive	
39	24V PULS+	24V Pulse Positive	High Level 24V Input
40	HSIGN-	High-speed Direction Negative	
41	PULS-	Pulse Negative	Low Level 0V Input
42	V_REF	Velocity Analog Command	
43	PULS+	Pulse Positive	High Level 5V Input

44	GND	Ground	
45	COM	+24V Output Ground	
46	HSIGN+	High-speed Positive	
47	COM	+24V Output Ground	
48	OCZ	Phase Z Open Collector Output	
49	COM	+24V Output Ground	
50	OZ+	Phase Z Output Positive	

Note:

1. As for the custom function settings of Digital Input(DI), Digital Output(DO), please refer to the parameters instructions in Chapter 8.
2. While CN1 is wiring, 24V PULS+ & PULS+ share PULS-, 24V SIGN+ & SIGN+ share SIGN-, the difference is one is 24V high level input, one is 5V high level input.

### 3.1.2 CN2 Port & Connection

CN2 is the port that connects drive with motor encoder feedback lead.

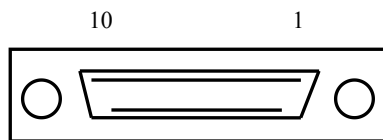

20 11  
CN 2 Port Specifics

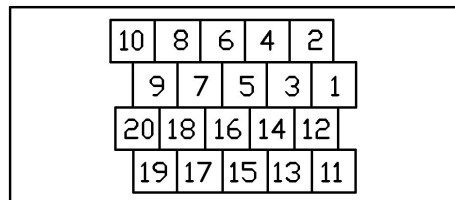

Map of SCSI-50P terminal pins in CN2 Port

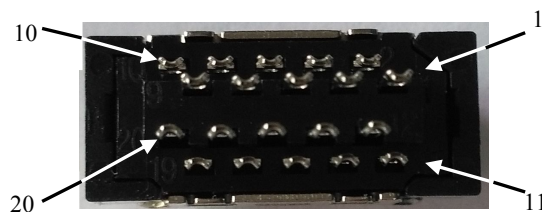

SCSI-20P physical photo

CN2 terminal pins definition:

Pin NO.	Symbol	Name	Descriptions
1	NC	None	
2	EZ-	Encoder Phase Z Input Inverted	
3	NC	None	

4	T-	Absolute encoder T-	For Absolute drive
5	T+	Absolute encoder T+	For Absolute drive
6	EW-	Magnet Pole Phase W Output Inverted	
7	EB+	Encoder Phase B Input	
8	EW+	Magnet Pole Phase W Input	
9	EB-	Encoder Phase B Input Inverted	
10	EZ+	Encoder Phase Z Input	
11	EA+	Encoder Phase A Input	
12	EA-	Encoder Phase A Input Inverted	
13	GND	Output Power Supply Ground	
14	+5V	Output 5V Power Supply	
15	GND	Output Power Supply Ground	
16	+5V	Output 5V Power Supply	
17	EV+	Magnet Pole Phase V Input	
18	EV-	Magnet Pole Phase V Input Inverted	
19	EU-	Magnet Pole Phase U Input Inverted	
20	EU+	Magnet Pole Phase U Input	

### 3.1.3 CN3 Port Definition

RS232 Communication Interface, & CN3 Crystal Plug Wiring definition

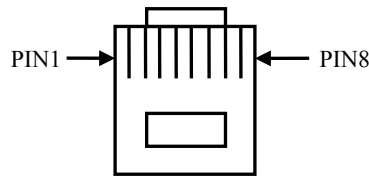

Pin NO.	Symbol	Descriptions
PIN1	GND	RS232 Ground
PIN2	TX232	RS232 Receive
PIN3	5V	RS232 Power Supply 5V
PIN4	RX232	RS232 Send
PIN5	Reserved	Connection Banned
PIN6	GND	RS485 Ground
PIN7	485-	
PIN8	485+	

### 3.1.4 CN4 Port Definition

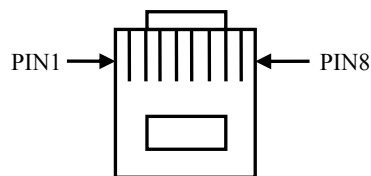

Pin NO.	Symbol	Descriptions
PIN1	Reserved	Connection Banned

PIN2	Reserved	Connection Banned
PIN3	Reserved	Connection Banned
PIN4	Reserved	Connection Banned
PIN5	Reserved	Connection Banned
PIN6	GND	RS485 Ground
PIN7	485-	
PIN8	485+	

### 3.1.5 Power Supply & Motor Power Line Port

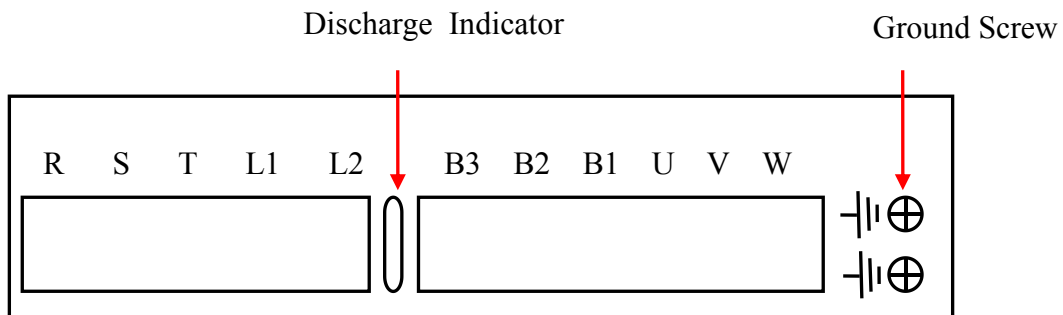

Symbol	Definition	Descriptions
R、 S、 T	Main Circuit Power Supply Input Connector	For Single Phase Wiring, S is not used
L1、 L2	Control Circuit Power Supply Input	Wiring Single Phase AC Current
U、 V、 W	Motor Power Lead Connector	Wiring Motor Power Lead
B1、 B2、 B3	Regenerative Resistor End Connector	Short-circuit B1,B2 while using built-in regenerative resistor. Connect resistor to B1,B3 while using external resistor.
Ground Screw	Drive PGND Screw	Wiring Power Supply ground Lead
Discharging Indicator	Drive Discharging Indication	Display if fully discharged

Note:

1. Please be sure electromagnetic contactor connects the main circuit between power supply and Servo Drive, so that be able to turn off power supply to avoid fire caused by overload when servo drive is malfunctioning.
2. 0.4 kw and no built-in regenerative resistor, the following drives when feedback energy beyond the absorptive capacity of capacitance will be AL.402 over voltage alarm. At this point to an external regenerative resistor and the P00-30, P00-31, P00-32 set to the corresponding values, see note 8.2.



# Chapter4 Installation instructions

## 4.1 Installation dimensions

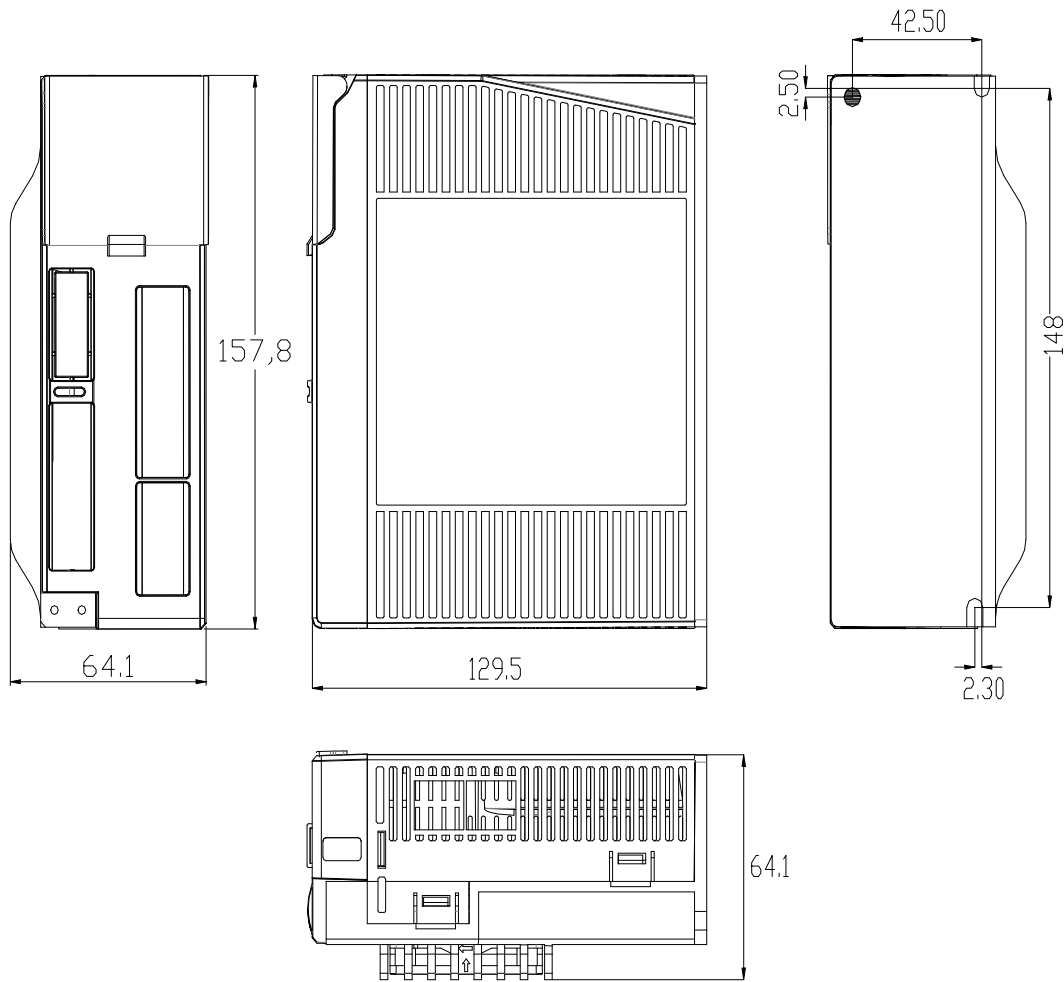

(1)400W AC servo drive (Units: mm)

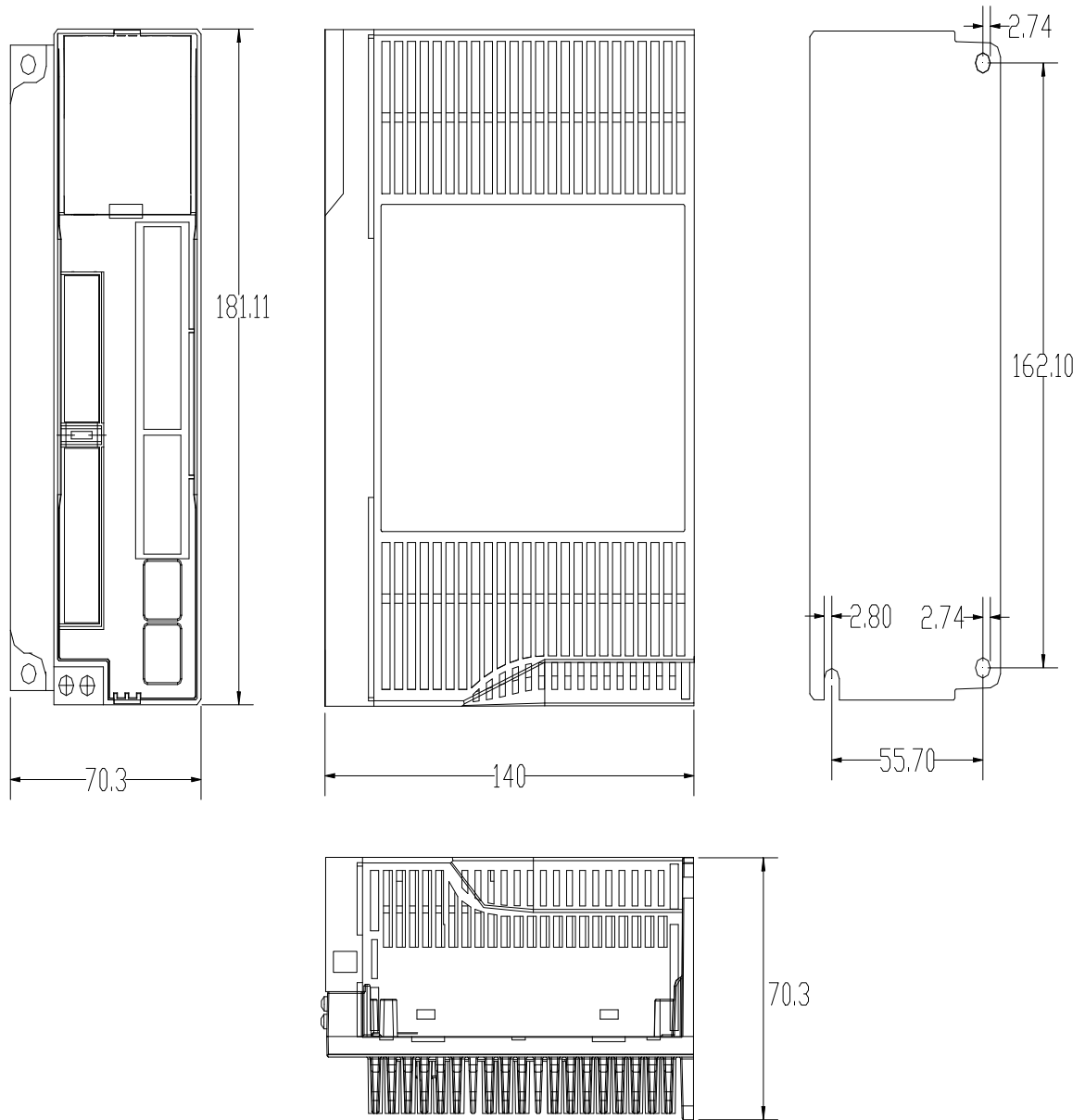

(2)400W ~ 1KW AC servo drive (Units: mm)

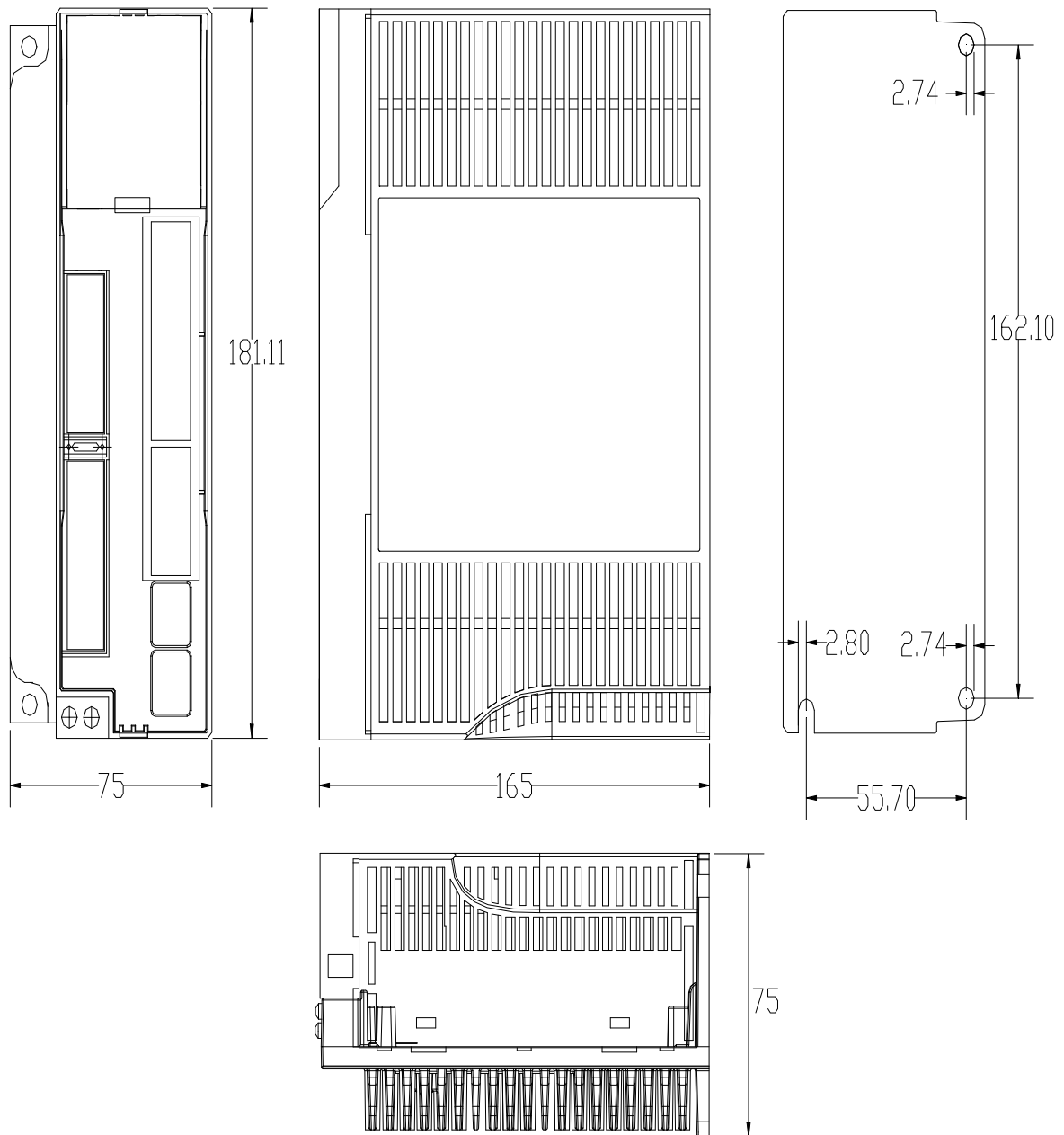

(3)JASD1.5KW ~ 2KW AC servo drive (Units: mm)

NOTE:

1. Normal installation direction of servo drive must be vertical direction, Top up to facilitate heat dissipation.
2. Drive when installation should guarantee the equipment well ventilated, when the cabinet has multiple drives tried for use to ensure that the distance between each other not less than 5 cm.
3. In order to ensure that the use of safe, please be sure to make the drives of terminals and devices protect good protective grounding.

## 4.2 Installation environment

Using the environment of the product are directly affects the normal work and life, so must meet the following conditions:



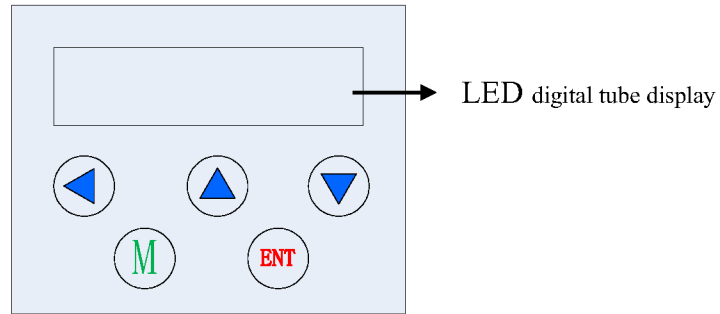

1. Working environment temperature : 0 to 55°C. Work environment humidity: 10% to 90% or less (free from condensation) .
2. Storage environment: -20°C~+85°C; Storage environment humidity: 93% or less (free from condensation) .
3. vibration : 0.5G or less
4. To prevent rain or damp environment.
5. Avoid exposure in the sun.
6. To prevent oil mist, the erosion of salt.
7. To prevent corrosive liquid, gas, etc.
8. To prevent dust, lint and metal fines.
9. Stay away from the radioactive material and fuel.
10. Ark need to reserve space around the drive put the position in the oven for easy loading and unloading of maintenance.
11. Pay attention to the tank in the air flow, if necessary, add outer fan to enhance the air flow, reduce drive environmental temperature for heat dissipation; The long-term working temperature under 55 °C.
12. Try to avoid near the vibration source, adding damping device such as vibration absorber or antivibration rubber gasket.
13. If there is electromagnetic interference sources, the power of the drive and control line Louis interference caused by misoperation, noise filter can be added or used in a variety of effective anti-interference measures in order to ensure the normal operation of the drive (noise filter can increase the leakage current, need to load an isolation transformer on the drive power input end).

## Chapter5 Panel display and setting

### 5.1 Introduced function of panel



JASD ac servo drive panel adopts six LED digital tube display; Five key input instructions, specific keys function as follows:

Panel key label	definition	instructions
	LEFT	Displacement function
	UP	Adjustment parameter, add functionality
	DOWN	Adjustment parameter, reduce functionality
	M KEY	Cancel out and switching function
	ENT KEY	Identify and save functions

Note: ENT button press 3 seconds long means determine or save function.

### 5.2 Operating mode switching process

JASD ac servo series four function models, there are State display mode、Monitor mode、Parameter set up mode、Auxiliary function mode. Switching mode between them as follow:

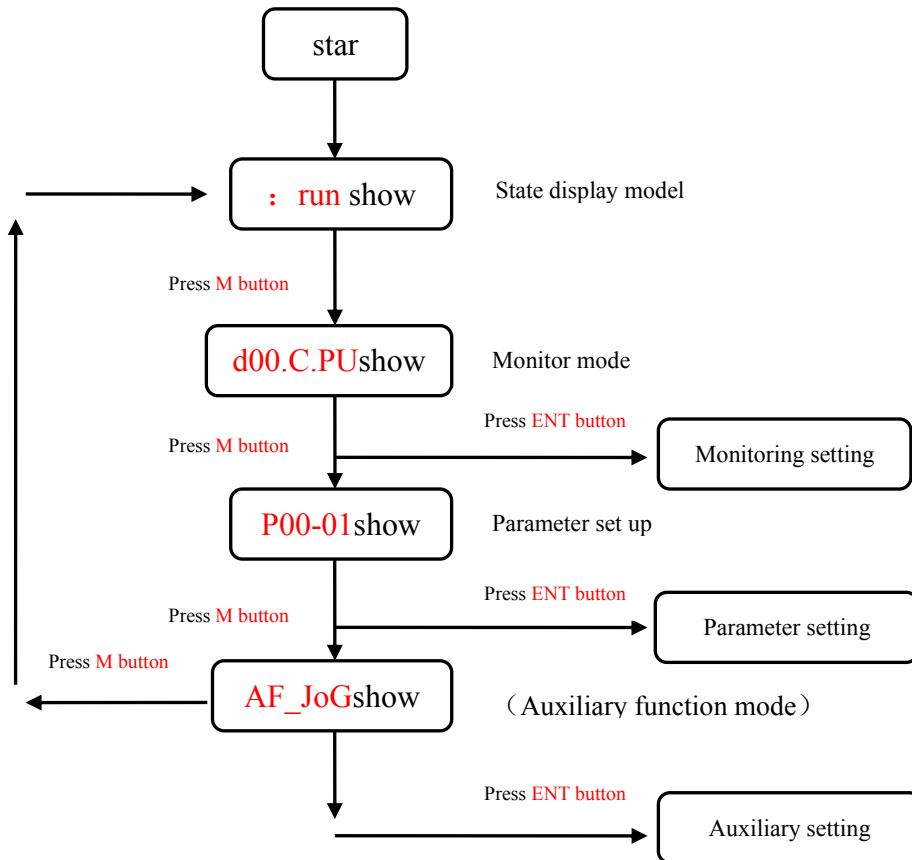

Note: Press ENT button Enter the mode setting and then you can exit mode selection by pressing the M key.

### 5.3 Status display

Display:

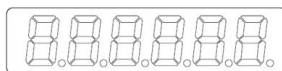

BitData | Symbol

Meaning:

display	meaning	display	meaning
	Control circuit power on		The main circuit power supply ready
	Speed and torque control: velocity matching Position control: Position coincide		Rotation detection
	ON: Motor is power off OFF: Motor is power on		Speed and torque control: Speed command inputting Position control: Position command inputting

The meaning of symbol:

Display	Meaning
	Servo is not ready(Motor is not power on)
	Servo is ready(Motor is not power on)
	Servo is running(Motor is power on)
	Forward drive state is prohibited Meant positive distance signal input port in a valid state
	Reverse drive state is prohibited Meant reverse distance signal input port in a valid state
	Servo fault status

#### 5.4 Write and save method parameter Settings

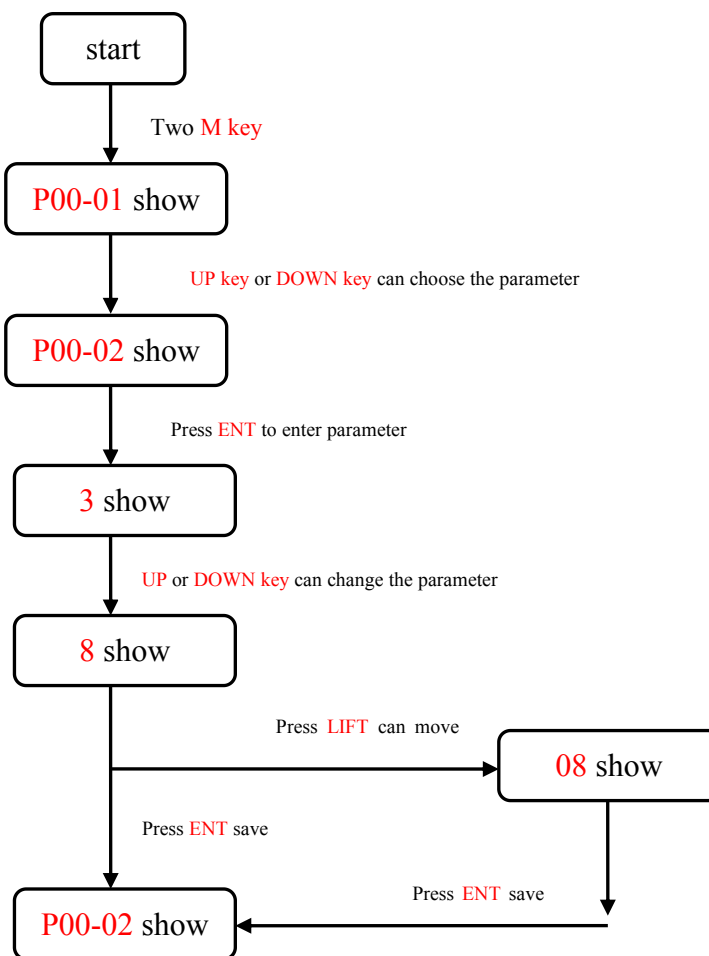

# Chapter6 control mode and setting

## 6.1 Position control

### 6.1.1 Position control wiring diagram

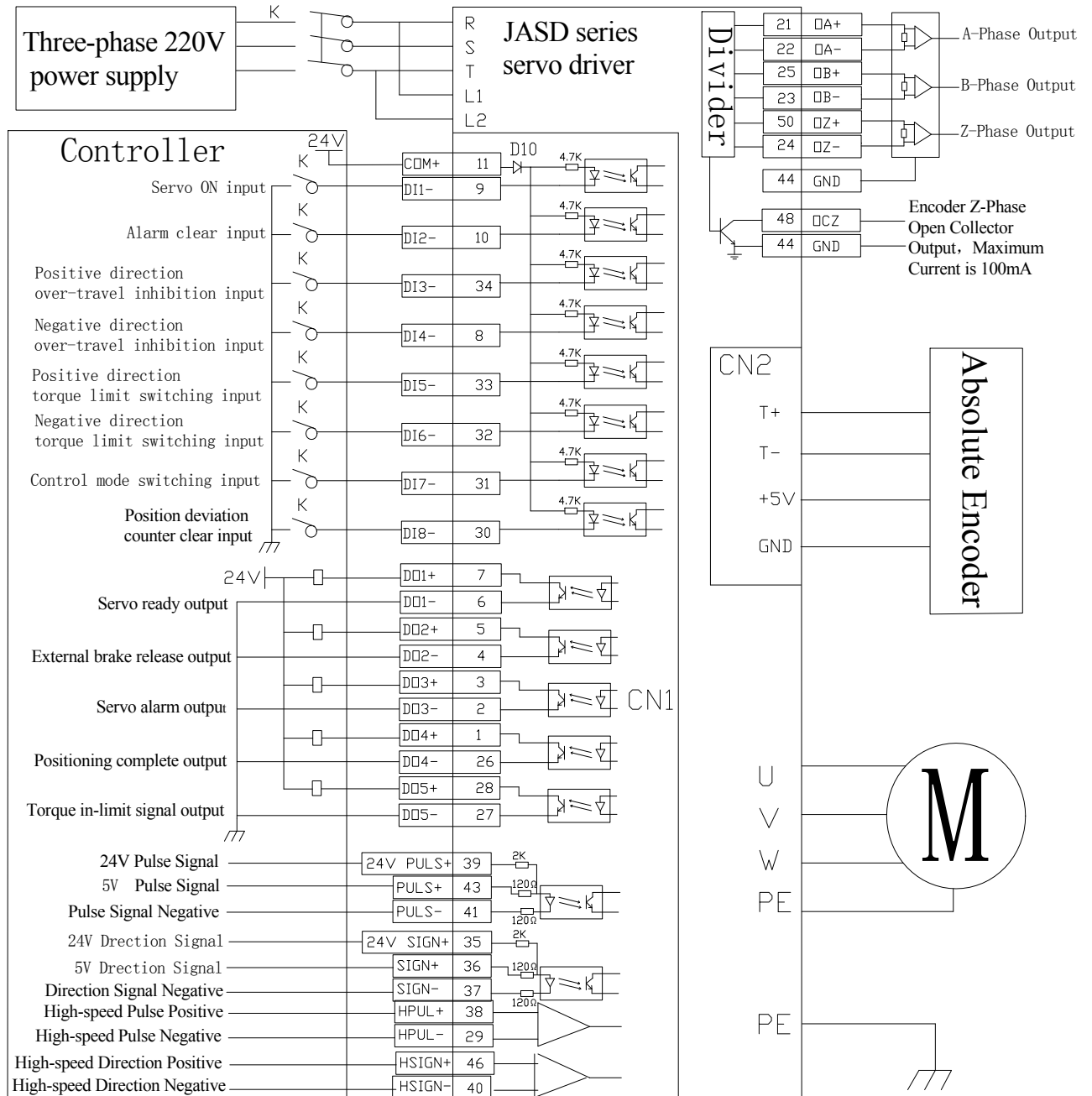



## 6.1.2 Position control command parameter

### 1、 Position control instruction related to motor and drive parameters

Parameter code	Name	Setting range	Factory setting	Instructions
P01-01	Control model setting	0-6	0	0: position mode (Pulse instructions) 1: speed mode (Analog instructions) 2: torque model (Analog instructions) 3: position/speed model 4: position/torque model 5: speed/torque model 6: full closed-loop model
P00-05	Motor pole logarithmic	1-31	4	Specific parameter setting depending on the motor
P0-07	Encoder type	0-3	0	
P00-10	Incremental encoder line number	0-65535	2500	
P03-00	Position command source	0-1	0	0: Pulse instruction 1: Numbers given
P03-01	Command pulse modes	0-3	1	0: Quadrature pulse instruction 1: Signal + pulse instruction 2 or 3: Double pulse instruction
P03-02	Command pulse input terminals	0-1	0	0: Low speed pulse 1: High speed pulse
P03-03	Command pulse invert	0-1	0	Set the motor rotating the initial direction
P03-10	electronic gear 1 molecule	1-65535	1	According to user requirements
P03-11	electronic gear 1 denominator	1-65535	1	

## 6.2 Speed control

### 6.2.1 Speed control wiring diagram

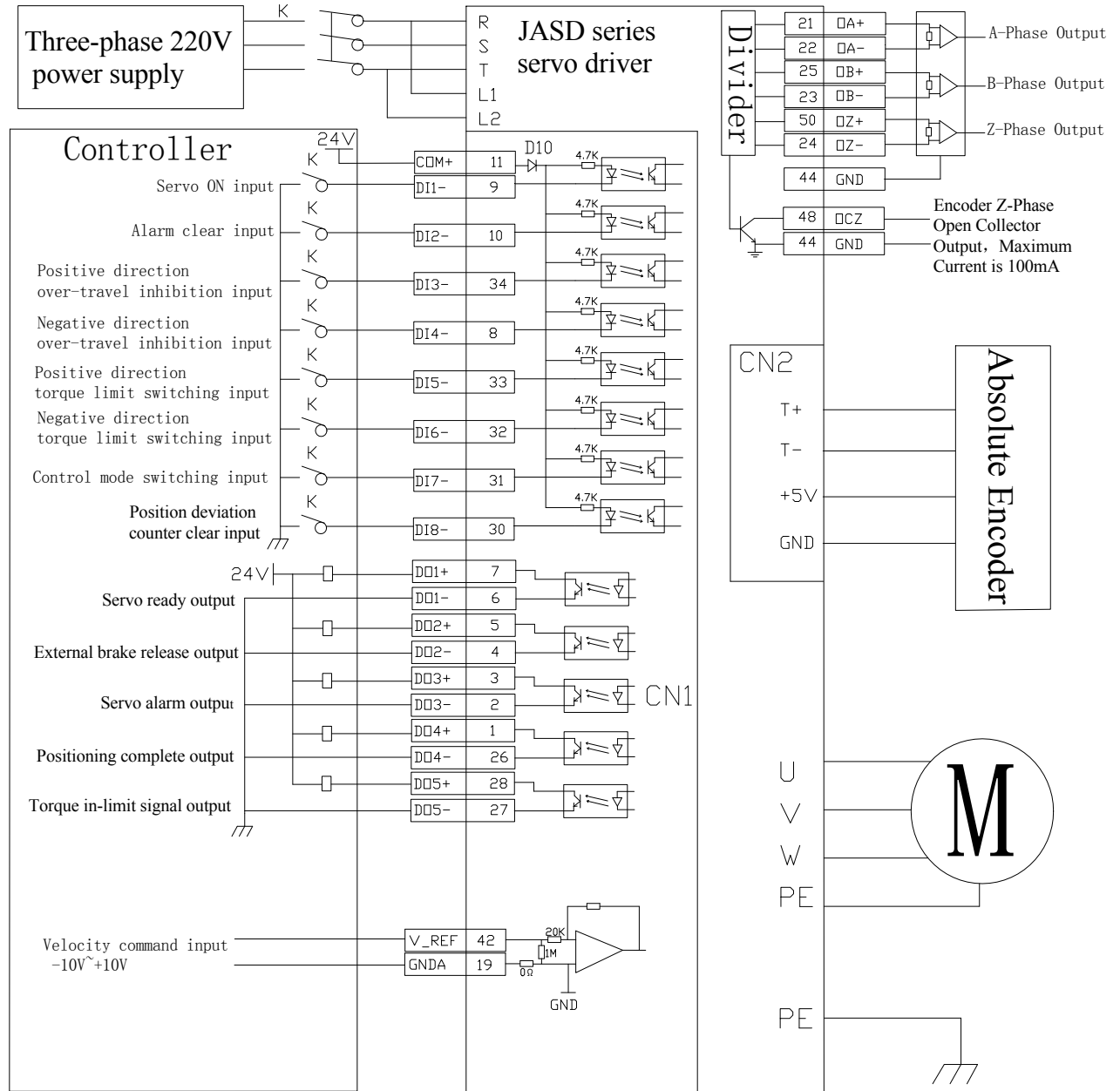

## 6.2.2 Speed control command parameters

### 1、Speed control instruction related to motor and drive parameters

Parameter code	Name	Setting range	Factory setting	Instructions
P01-01	Control mode setting	0-6	1	0: position mode (Pulse instructions) 1: speed mode (Analog instructions) 2: torque mode (Analog instructions) 3: position/speed model 4: position/torque model 5: speed/torque model 6: full closed-loop model
P00-05	Motor pole logarithmic	1-31	---	Specific parameter setting depending on the motor
P00-07	encoder type	0-3	---	
P00-10	Incremental encoder line number	0-65535	---	
P04-00	Source of rotational speed	0-3	0	0: External analog instruction 1: Digital command (parameters) 2: Digital instruction (communication) 3: Internal multiple sets of instructions
P04-01	Speed analog command inverting	0-1	0	Set the motor rotating the initial direction
P04-02	Digital speed command value	0-Max.Speed	0	Set the speed reference
P04-06	Forward speed limit	0-Max.Speed		Positive direction speed limit
P04-07	Reverse speed limit	0-Max.Speed		Reverse rotation speed limit

### 2、speed control instruction related gain parameters

Please refer to the [6.1 Position control of the position control instructions relevant adjusted gain parameter](#)

## 6.3 Torque control

### 6.3.1 Torque control wiring diagram

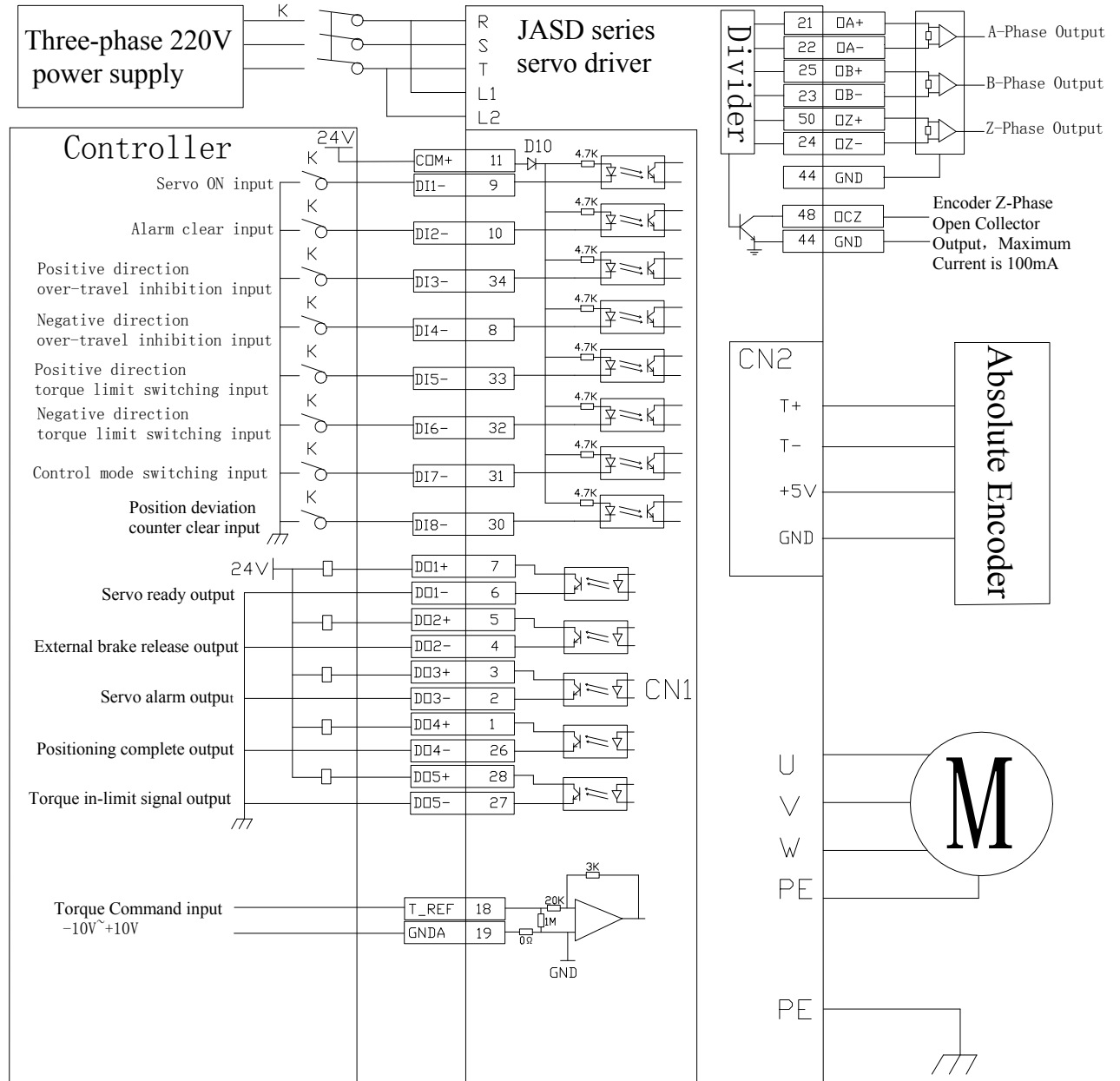

### 6.3.2 The torque control command parameters

#### 1、Torque control instruction related to motor and drive parameters

Parameter code	Name	Setting range	Factory setting	Instructions
P01-01	Control mode setting	0-6	2	0: position mode (Pulse instructions) 1: speed mode (Analog instructions) 2: torque model (Analog instructions) 3: position/speed model 4: position/torque model 5: speed/torque model 6: full closed-loop model
P00-05	Motor pole logarithmic	1-31	4	Specific parameter setting depending on the motor
P00-07	encoder type	0-3	0	
P00-10	Incremental encoder line number	0-65535	2500	
P05-00	Torque command source	0-3	0	0: External analog instruction 1: Digital command (parameters) 2: Digital instruction (communication) 3: Internal multiple sets of instructions
P05-01	Torque analog command inverting	0-1	0	Set the motor rotating the initial direction
P05-02	Torque mode speed limiting value	0-highest speed	1000	Set the highest speed
P05-10	Internal positive direction torque limit	0-300.0	200.0	Limit Positive direction torque
P05-11	Internal negative direction torque limit	0-300.0	200.0	Limit reverse direction torque

#### 2、Torque control instruction related to gain parameters

Please refer to the **6.1 Position control of the position control instructions relevant adjusted gain parameter**

## Chapter7 Trial Running

### 7.1 Inspection before running

In order to avoid damage to the servo drive or mechanism, please remove all the load of the servo motor before running and check the attentions. Then do the no load test. If normal, connect the servo motor's load and do the next test.

Attentions:

Inspection before power on	<ol style="list-style-type: none"><li>1. Check whether the appearance of the servo drive is damaged.</li><li>2. Insulating the wiring terminal.</li><li>3. Check the drive, whether there is a foreign body inside</li><li>4. Don't put the servo drive and motor on the Combustion object.</li><li>5. To avoid the failure of magnetic brake, pls inspect whether the 'immediately stop' and 'cut off the power circuit' can work properly.</li><li>6. Confirm the servo drive's voltage of external power supply is meet the requirement.</li><li>7. Confirm the connection of U, V, W, (motor's power wiring),encoder and signal wiring .(according to the motor's label and manual)</li></ol>
Inspection when power on	<ol style="list-style-type: none"><li>1. When power on(servo drive),whether can hear the sound of relay.</li><li>2. Check whether the display of "power light" and "LED" is normal</li><li>3. Whether the shaft of servo motor is self-locking.</li><li>4. During the running, if the servo motor is vibrate and sound is too large .pls contact the manufacture.</li></ol>

### 7.2 Trial Running with no load.

1.Trial Running with no load in JOG mode, user do not need to connect the additional wiring. For safe, before the test, pls fix the motor's frame .To prevent the danger caused by the counterforce which produced by the change of motor' s rotational speed.

Wiring diagram of JOG mode:

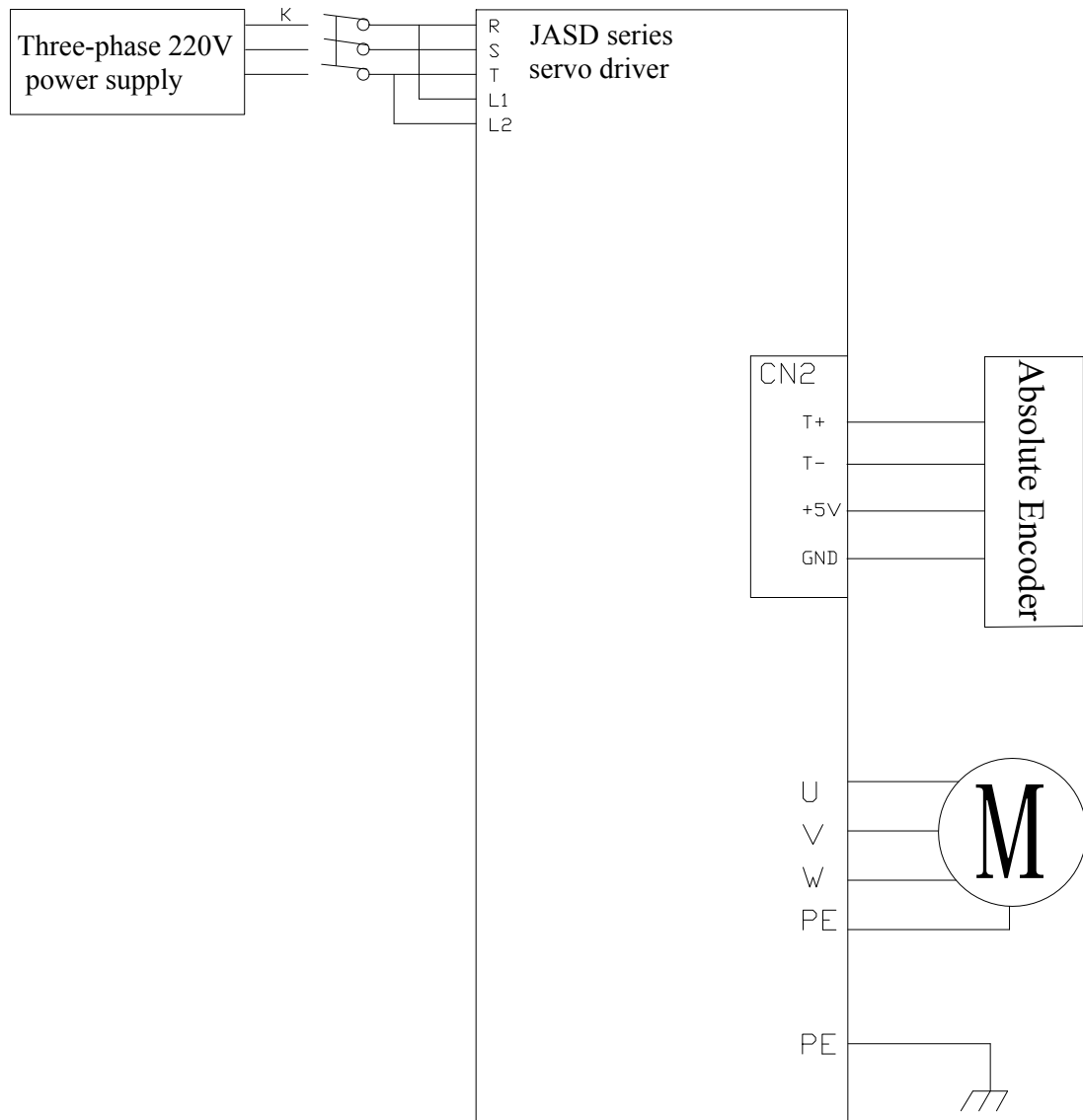

2. Select the JOG mode according to the following flow chart .

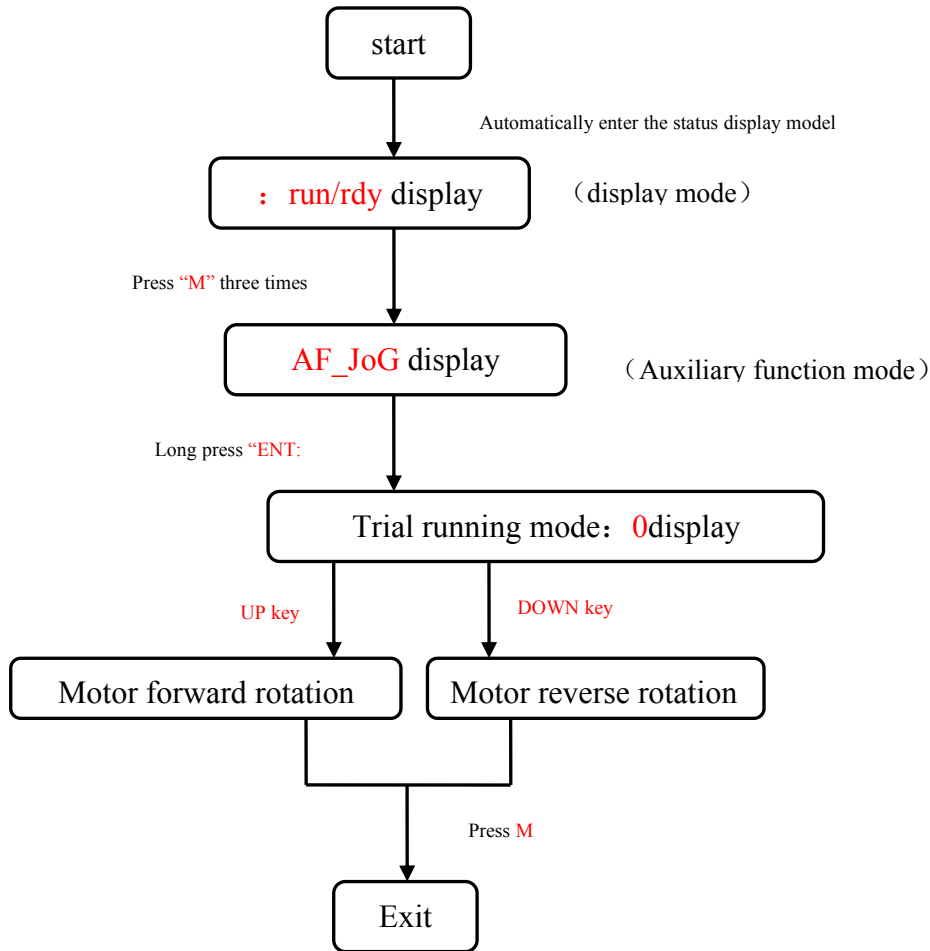



## Chapter8 Parameter and Function

### 8.1 parameter

P00-xx: motor and drive's parameter

P01-xx: Main Control parameter

P02-xx: Gain parameter

P03-xx: Position parameter

P04-xx: Velocity parameter

P05-xx: Torque parameter

P06-xx: I/O parameter

P08-xx: Advanced Function parameter

Parameter No.	Title	Range	Default	Unit	Effective Time
P00-00	Motor SN		---		Power-On again
P00-01	Motor rated speed	1-6000	---	rpm	Power-On again
P00-02	Motor rated torque	0.01-655.35	---	n.m	Power-On again
P00-03	Motor rated current	0.01-655.35	---	Arms	Power-On again
P00-04	Motor rotary inertia	0.01-655.35	---	kg.cm <sup>2</sup>	Power-On again
P00-05	Motor pole numbers	1-31	---	pole pair	Power-On again
P00-07	Encoder type	0-3	---	---	Power-On again
P00-08	Incremental encoder type	0-1	---	---	Power-On again
P00-09	Absolute encoder type	0-1	---	---	Power-On again
P00-10	Incremental encoder PPR	0-65535	---		Power-On again
P00-11	Incremental encoder Z pulse electric angel	0-65535	---		Power-On again
P00-12	Rotor initial angel 1	0-360	---	1degree	Power-On again
P00-13	Rotor initial angel 2	0-360	---	1degree	Power-On again
P00-14	Rotor initial angel 3	0-360	---	1degree	Power-On again
P00-15	Rotor initial angel 4	0-360	---	1degree	Power-On again
P00-16	Rotor initial angel 5	0-360	---	1degree	Power-On again
P00-17	Rotor initial angel 6	0-360	---	1degree	Power-On again
P00-20	Drive SN	---	---	---	Read only
P00-21	RS232 baud rate setup	0-3	0	---	Power-On again
P00-30	Regenerative resistor setup	0-2	2	---	Power-On again
P00-31	External regenerative resistor power	0-65535	0	1W	Power-On again
P00-32	External regenerative resistor's resistance value	0-1000	0	1ohm	Power-On again
P01-00	Rotational direction setup	0-1	0	---	Immediate
P01-01	Control mode setup	0-6	0	---	Immediate
P01-02	Real-time auto-gain tuning mode setup	0-3	1	---	Immediate

P01-03	Real-time auto-gain tuning level setup	0-31	13	---	Immediate
P01-04	Inertia ratio	0-100.00	100	1.00%	Immediate
P01-30	Brake-command-servo off, delay time(brake open delay)	0-255	100	1ms	Immediate
P01-31	Brake release speed setup	0-Max.Speed	30	1rpm	Immediate
P01-32	Mechanical brake action at running setup	0-255	100	1ms	Immediate
P01-40	Lose control alarm Enable	0-1	1	---	Immediate
P02-00	1st gain of position loop	0-3000.0	80.0	1/S	Immediate
P02-01	2nd gain of position loop	0-3000.0	80.0	1/S	Immediate
P02-03	Velocity feed forward gain	0-100.0	30.0	1.0%	Immediate
P02-04	Velocity feed forward filter	0-64.00	0.5	1ms	Immediate
P02-10	1st gain of velocity loop	1.0-2000.0	40.0	1Hz	Immediate
P02-11	1st Velocity integral constant	1.0-1000.0	10.0	1ms	Immediate
P02-12	1st PDFF gain of velocity loop	0-100.0	100.0	1.0%	Immediate
P02-13	2nd gain of velocity loop	1.0-2000.0	45.0	1Hz	Immediate
P02-14	2nd Velocity integral constant	1.0-1000.0	1000.0	1ms	Immediate
P02-15	2nd PDFF gain of velocity loop	0-100.0	100.0	1.0%	Immediate
P02-19	Torque feed forward gain	0-30000	0	1.0%	Immediate
P02-20	Torque feed forward filter	0-64.00	0.8	1ms	Immediate
P02-30	Mode of gain switching	0-10	7	---	Immediate
P02-31	Level of gain switching	0-20000	800	---	Immediate
P02-32	Hysteresis at gain switching	0-20000	100	---	Immediate
P02-33	Delay time of gain switching	0-1000.0	10.0	1ms	Immediate
P02-34	Position gain switching time	0-1000.0	10.0	1ms	Immediate
P02-40	Mode switch setup	0-4	0	---	Immediate
P02-41	Level of mode switch	0-20000	10000	---	Immediate
P02-50	Torque command additional value	-100.0-100.0	0	1.0%	Immediate
P02-51	Positive direction torque compensation value	-100.0-100.0	0	1.0%	Immediate
P02-52	Negative direction torque compensation value	-100.0-100.0	0	1.0%	Immediate
P03-00	Position command source	0-1	0	---	Immediate
P03-01	Command pulse format	0-3	1	---	Immediate
P03-02	Command pulse input terminal	0-1	0	---	Immediate
P03-03	Command pulse rotational direction setup	0-1	0	---	Immediate
P03-05	Positioning complete(In-Position) setup	0-65535	1	---	Immediate
P03-06	Positioning complete(In-Position) range	0-65535	100	Encoder unit	Immediate
P03-10	1st numerator of electronic gear	0-65535	8192	---	Power-On again
P03-11	1st Denominator of electronic gear	0-65535	625	---	Power-On again
P03-15	Position deviation excess setup	0-65535	30000	Encoder	Immediate

				unit *256	
P03-16	Position command smoothing filter	0-1000.0	0	1ms	Immediate
P03-17	Position command FIR filter	0-1000.0	0	1ms	Immediate
P03-20	Position feedback source	0-1	0	---	Immediate
P03-21	Pulse output division enable	0-1	1	---	Immediate
P03-22	Numerator of Pulse output division	0-65535	1	---	Immediate
P03-23	Denominator of Pulse output division	0-65535	1	---	Immediate
P03-25	Output pulse counts per one motor revolution(Absolute Encoder)	0-65535	2048	---	Immediate
P03-30	Linear encoder phase setup	0-1	0	---	Immediate
P03-31	Linear encoder polarity of Z pulse	0-1	1	---	Immediate
P03-40	Pulse output source	0-1	0	---	Immediate
P03-41	Output pulse phase	0-1	0	---	Immediate
P03-42	Output polarity of Z pulse	0-1	1	---	Immediate
P04-00	Selection of speed command	0-3	0	---	Immediate
P04-01	Speed analog command inverting	0-1	0	---	Immediate
P04-02	Digital speed command value	±Max.Speed	0	1rpm	Immediate
P04-03	Speed zero-clamp function setup	0-1	0	---	Immediate
P04-04	Speed zero clamp level	0-Max.Speed	30	1rpm	Immediate
P04-05	Over-speed level setup	0-Max.Speed	6200	1rpm	Immediate
P04-06	Positive speed limit value	0-Max.Speed	5000	1rpm	Immediate
P04-07	Negative speed limit value	0-Max.Speed	5000	1rpm	Immediate
P04-10	Zero-speed	0-200.0	2	1rpm	Immediate
P04-11	Motor speed threshold	0-200.0	30	1rpm	Immediate
P04-12	Speed coincidence range	0-200.0	30	1rpm	Immediate
P04-14	Acceleration time setup	0-10000	0	1ms/1000r	Immediate
P04-15	Deceleration time setup	0-10000	0	pm	Immediate
P04-30	1st speed of speed setup	±Max.Speed	0	1rpm	Immediate
P04-31	2nd speed of speed setup	±Max.Speed	0	1rpm	Immediate
P04-32	3rd speed of speed setup	±Max.Speed	0	1rpm	Immediate
P04-33	4th speed of speed setup	±Max.Speed	0	1rpm	Immediate
P04-34	5th speed of speed setup	±Max.Speed	0	1rpm	Immediate
P04-35	6th speed of speed setup	±Max.Speed	0	1rpm	Immediate
P04-36	7th speed of speed setup	±Max.Speed	0	1rpm	Immediate
P04-37	8th speed of speed setup	±Max.Speed	0	1rpm	Immediate
P05-00	Selection of torque command	0-3	0	---	Immediate
P05-01	Torque analog command inverting	0-1	0	---	Immediate
P05-02	Speed limit in torque control	0-Max.Speed	1000	1rpm	Immediate
P05-10	Internal forward torque limit	0-300.0	200.0	1.0%	Immediate
P05-11	Internal reverse torque limit	0-300.0	200.0	1.0%	Immediate
P05-12	External forward torque limit	0-300.0	100.0	1.0%	Immediate
P05-13	External reverse torque limit	0-300.0	100.0	1.0%	Immediate

P06-00	DI1 logic selection	0-4	0	---	Power-On again
P06-01	DI1 function selection	0-18	1	---	Power-On again
P06-02	DI2 logic selection	0-4	0	---	Power-On again
P06-03	DI2 function selection	0-18	2	---	Power-On again
P06-04	DI3 logic selection	0-4	0	---	Power-On again
P06-05	DI3 function selection	0-18	3	---	Power-On again
P06-06	DI4 logic selection	0-4	0	---	Power-On again
P06-07	DI4 function selection	0-18	4	---	Power-On again
P06-08	DI5 logic selection	0-4	0	---	Power-On again
P06-09	DI5 function selection	0-18	7	---	Power-On again
P06-10	DI6 logic selection	0-4	0	---	Power-On again
P06-11	DI6 function selection	0-18	8	---	Power-On again
P06-12	DI7 logic selection	0-4	0	---	Power-On again
P06-13	DI7 function selection	0-18	5	---	Power-On again
P06-16	DI8 logic selection	0-4	0	---	Power-On again
P06-17	DI8 function selection	0-18	16	---	Power-On again
P06-20	DO1 logic selection	0-1	1	---	Power-On again
P06-21	DO1 function selection	0-11	3	---	Power-On again
P06-22	DO2 logic selection	0/1	1	---	Power-On again
P06-23	DO2 function selection	0-11	2	---	Power-On again
P06-24	DO3 logic selection	0/1	1	---	Power-On again
P06-25	DO3 function selection	0-11	1	---	Power-On again
P06-26	DO4 logic selection	0/1	1	---	Power-On again
P06-27	DO4 function selection	0-11	4	---	Power-On again
P06-28	DO5 logic selection	0/1	1	---	Power-On again
P06-29	DO5 function selection	0-11	8	---	Power-On again
P06-40	Input gain of speed command	10-2000	500	1rpm/V	Immediate
P06-41	Filter of speed command input	0-64.00	0.8	1ms	Immediate
P06-42	Offset of speed command	-10.000 -10.000	0	1V	Immediate
P06-43	Input gain of torque command	0.0-100.0	30	%	Immediate
P06-44	Filter of torque command input	0-64.00	0.8	1ms	Immediate
P06-45	Offset of torque command	-10.000 -10.000	0	1V	Immediate
P08-01	Offline inertia auto-tuning mode selection	0-1	0		Immediate
P08-02	Maximum speed for inertia auto-tuning	100-2000	800	1rpm	Immediate
P08-03	Time constant of acceleration to max speed for inertia auto-tuning	20-800	100	1ms	Immediate
P08-04	Interval after an inertia auto-tuning	50-10000	1000	1ms	Immediate
P08-05	Motor revolution for an inertia auto-tuning			turns	Read only
P08-11	Adaptive filter mode setup	0-4	0	---	Immediate

P08-20	Time constant of torque filter	0-25.00	0.8	1ms	Immediate
P08-25	Disturbance torque compensating gain	0-100.0	0	%	Immediate
P08-26	Disturbance observer filter	0-25.00	0.8	1ms	Immediate
P08-30	1st notch frequency	50-5000	5000	Hz	Immediate
P08-31	1st notch width selection	0-20	2	---	Immediate
P08-32	1st notch depth selection	0-99	0	---	Immediate
P08-33	2nd notch frequency	50-5000	5000	Hz	Immediate
P08-34	2nd notch width selection	0-20	2	---	Immediate
P08-35	2nd notch depth selection	0-99	0	---	Immediate
P08-36	3rd notch frequency	50-5000	5000	Hz	Immediate
P08-37	3rd notch width selection	0-20	2	---	Immediate
P08-38	3rd notch depth selection	0-99	0	---	Immediate
P08-39	4th notch frequency	50-5000	5000	Hz	Immediate
P08-40	4th notch width selection	0-20	2	---	Immediate
P08-41	4th notch depth selection	0-99	0	---	Immediate

## 8.2 Parametric analysis

P00-xx: motor and drive's parameter

Parameter Code	Designation	Introductions
P00-00	Motor No	Factory has been set, no need to set
P00-01	Motor rated speed	Factory has been set, no need to set
P00-02	Motor rated torque	Set according to the motor, the factory has set up
P00-03	Motor rated current	Set according to the motor, the factory has set up
P00-04	Motor moment of inertia	Set according to the motor, the factory has set up
P00-05	Motor pole pairs	Set according to the motor, the factory has set up
P00-07	Encoder selection	0, 1: Incremental encoder 2: Single cycle absolute encoder 3: Multi ring absolute encoder
P00-08	Linear incremental encoder	0: Non provincial line type 1: Provincial line type
P00-09	Absolute value encoder type	0: Tamagawa encoder 1: Nikon encoder
P00-10	Incremental encoder PPR	Set according to the motor, the factory has set up
P00-11	Incremental encoder Z pulse electric angel	
P00-12	Rotor initial angel 1	1degrees
P00-13	Rotor initial angel 2	1degrees
P00-14	Rotor initial angel 3	1degrees
P00-15	Rotor initial angel 4	1degrees
P00-16	Rotor initial angel 5	1degrees
P00-17	Rotor initial angel 6	1degrees

P00-20	Drive's SN	
P00-21	RS232 baud rate selection	0: 9600bps 1: 19200bps 2: 57600bps 3: 115200bps
P00-30	Brake resistor setting	0: Use built-in resistance 1: Using external resistors 2: Do not use the brake resistance
P00-31	External braking resistor power	1W
P00-32	External braking resistor's resistance value	1ohm

#### P01-xx: Main Control parameter

Parameter Code	Designation	Introductions
P01-00	Rotation direction setting	0: Forward direction 1: Reverse direction
P01-01	Control mode setting	0: Position control mode (pulse sequence) 1: Speed control mode (analog command) 2: Torque control mode (analog command) 3: Position and speed control mode 4: Position and torque control mode 5: Speed and torque control mode 6: Full closed loop control mode
P01-02	Real time automatic adjustment mode	0: Manual adjustment of rigidity 1: Automatic adjustment of the standard model. This mode, the parameter P02-00, P02-01, P02-10, P02-11, P02-13, P02-14, P08-20 will automatically according to the rigid hierarchy of P01-03 set, does not make sense to manually adjust these parameters 2: Positioning mode automatically adjust rigidity. This mode, the parameter P02-00, P02-01, P02-10, P02-11, P02-13, P02-14, P08-20 will automatically according to the rigid hierarchy of P01-03 set, does not make sense to manually adjust these parameters. The following parameters will be for a fixed value. P02-03: 30.0% P02-04: 0.50
P01-03	Real time automatic adjustment of rigid setting	Built in 32 kinds of gain parameters, customers can directly call according to the actual situation, the greater the value, the stronger the rigidity. When P01-02 set to 1, or 2 time
P01-04	Rotary inertia ratio	1.00%
P01-30	Brake-command-servo off, delay time(brake open delay)	Range:0-255 Unit:1ms Servo On: when drive can make instruction, after P01-30 time, drive will receive position command.

		Servo off: Motor in the stationary state, perform clearance after enabling instruction, motor into the current state of actual time.
P01-31	brake command output the speed limit value	Range:0-Max.speed Unit:1rpm Motor in rotating condition, the motor speed threshold of the brake output is valid. Instructions below this threshold, the brake effectively, otherwise will wait P01-32 time, brake output instruction is effective.
P01-32	Servo off-waiting time of brake command	Range:0-255 Unit:1ms Motor in rotating condition, The longest waiting time of the brake output.
P01-40	Out of control error	0: Enable 1: Disable

#### P02-xx: Gain parameter

Parameter Code	Designation	Introductions
P02-00	1st gain of Position control	Range:0-3000.0 Unit:1/s <ul style="list-style-type: none"> <li>▸ Position loop proportional gain parameter value is greater, the gain ratio is higher, the greater stiffness, the position tracking error is smaller, quicker response. But the parameters too easily lead to vibration and overshoot.</li> <li>▸ This parameter is aimed at the static response</li> </ul>
P02-01	2nd gain of Position control	Range:0-3000.0 Unit:1/s <ul style="list-style-type: none"> <li>▸ Proportion gain of position loop controller, the greater the parameter value, the higher the gain ratio, the greater the stiffness, the smaller the position tracking error, and the faster response. But the parameters are too large to cause vibration and overshoot.</li> <li>▸ This parameter is aimed at dynamic response</li> </ul>
P02-03	Velocity feed forward gain	Range:0-100.0 Unit:1.0% <ul style="list-style-type: none"> <li>▸ The greater the feed forward gain of the position loop, the greater the parameter value is, the smaller the tracking error of the system is, the faster the response is. When set to 100%, indicates that any frequency of the instruction pulse, the location of the hysteresis is always 0.</li> <li>▸ The feed forward gain ratio of position loop is too large, so that the position loop of the system is unstable and prone to shock, and the feed forward gain ratio of position loop is usually 0.</li> </ul>
P02-04	Velocity feed forward smoothing constant	Range:0-64.00 Unit:1ms This parameter is used to set up the feed forward filter time constant of velocity loop.
P02-10	1st gain of velocity loop	Range:0-2000.0 Unit:1Hz <ul style="list-style-type: none"> <li>▸ The greater the speed ratio gain, the greater the servo stiffness, the faster the speed response, but it is too easy to produce vibration and noise.</li> </ul>

		<ul style="list-style-type: none"> <li>▸ In the system does not produce shock conditions, as far as possible to increase the value of this parameter.</li> <li>▸ This parameter is aimed at the static response</li> </ul>
P02-11	1st Velocity integral constant	<p>Range:0-1000.0 Unit:1ms</p> <ul style="list-style-type: none"> <li>▸ Speed regulator integral time constant, set the value of the smaller, faster integration, the greater the stiffness, too small to produce vibration, noise.</li> <li>▸ In the case of the system does not appear in the shock, as far as possible to reduce the value of this parameter.</li> <li>▸ This parameter is aimed at the static response</li> </ul>
P02-12	1st PDFF gain of velocity loop	<p>Range:0-100.0 Unit:1.0%</p> <ul style="list-style-type: none"> <li>▸ Set to 100.0%, the speed loop PI control, fast dynamic response; Set to zero, the speed loop integral action, can filter the low frequency disturbance, but slow dynamic response.</li> <li>▸ By adjusting the parameter, can make the speed loop has a better dynamic response, at the same time can increase the low frequency interference resistance ability</li> </ul>
P02-13	2nd gain of velocity loop	<p>Range:0-2000.0 Unit:1Hz</p> <ul style="list-style-type: none"> <li>▸ The greater the speed ratio gain, the greater the servo stiffness, the faster the speed response, but it is too easy to produce vibration and noise.</li> <li>▸ In the system does not produce shock conditions, as far as possible to increase the value of this parameter.</li> <li>▸ This parameter is aimed at dynamic response</li> </ul>
P02-14	2nd Velocity integral constant	<p>Range:0-1000.0 Unit:1ms</p> <ul style="list-style-type: none"> <li>▸ Speed regulator integral time constant, set the value of the smaller, faster integration, the greater the stiffness, too small to produce vibration, noise.</li> <li>▸ In the case of the system does not appear in the shock, as far as possible to reduce the value of this parameter.</li> <li>▸ This parameter is aimed at dynamic response</li> </ul>
P02-15	2nd PDFF gain of velocity loop	<p>Range:0-100.0 Unit:1.0%</p> <ul style="list-style-type: none"> <li>▸ Set to 100.0%, the speed loop PI control, fast dynamic response; Set to zero, the speed loop integral action, can filter the low frequency disturbance, but slow dynamic response.</li> <li>▸ By adjusting the parameter, can make the speed loop has a better dynamic response, at the same time can increase the low frequency interference resistance ability</li> </ul>
P02-19	Torque feed forward gain	Set current loop feed forward weighted value. The parameter is weighted by the differential of the speed command, and the current loop is added.
P02-20	Torque feed forward smoothing constant	This parameter is used to set the time constant of the torque feed forward filter.
P02-30	Gain switching mode	



P02-31	The level of gain switching	
P02-32	Gain switching hysteresis	
P02-33	Gain switching delay	1ms
P02-34	Position gain switching time	1ms
P02-40	Model switch selection	
P02-41	Model switch class	
P02-50	Torque command additional value	Range:-100.0-100.0 Unit:1.0% Set up the offset load compensation value usually added to the torque command in control mode except for the torque control mode
P02-51	Forward torque compensation value	Range:-100.0-100.0 Unit:1.0% Set up the dynamic friction compensation value to be added to the torque command when forward position command is fed
P02-52	Reverse torque compensation value	Range:-100.0-100.0 Unit:1.0% Set up the dynamic friction compensation value to be added to the torque command when negative direction position command is fed

#### P03-xx: Position parameter

Parameter Code	Designation	Introductions
P03-00	Location command source	0: pulse command 1: Digital given
P03-01	Command pulse mode	0: Quadrature pulse instruction 1: Signal + pulse instruction 2 or 3: Double pulse instruction
P03-02	Command pulse input terminal	0:low speed pulse 1:high speed pulse
P03-03	Command pulse counter	Used to adjust the counting direction: 0: Normal. 1: Reverse direction
P03-05	Location complete judgment condition	0: Output when position deviation is less than threshold P03-06 1: The position given, and position deviation when the output is less than threshold P03-06 2: The position given complete (filtered), and the position deviation is less than threshold P03-06
P03-06	Positioning complete scope	Encoder unit
P03-10	Molecule of Electronic gear 1	Calculation formula of electronic gear ratio:
P03-11	Denominator of Electronic gear 1	$G = \frac{\text{molecular}}{\text{denominator}}$ $N : \text{Motor rotation laps}$ $C : \text{encoder line number}$ $P : \text{Each lap input pulse number}$

		<p>case : Encoder line number is 2500 ;  Each lap input pulse number is 3200 ,  Electronic gear ratio ?</p> $G = \frac{N \times C \times 4}{P} = \frac{1 \times 2500 \times 4}{3200} = \frac{10000}{3200} = \frac{25}{8}$
P03-15	Position deviation excess setup	Range: 0-65535 Unit:256 Sets the number of pulses that allow the deviation, exceeding the set value of the alarm.
P03-16	Position command smoothing filter	Range: 0-65535, Unit:1ms Set up the time constant of 1st delay filter in response to the position command.
P03-17	Position command FIR filter	1ms
P03-20	Position loop feedback source	
P03-21	Encoder frequency output enable	
P03-22	numerator: incremental encoder output pulse frequency division ratio	
P03-23	Denominator: incremental encoder output pulse frequency division ratio	
P03-25	Output pulse counts per one absolute motor revolution	
P03-30	Linear encoder inverting	
P03-31	Z pulse's polarity of linear encoder	
P03-40	Output pulse resource	
P03-41	Output source inverting	
P03-42	Output Z pulse's polarity	

P04-xx : Velocity parameter

Parameter Code	Designation	Introductions
P04-00	Speed command source	0: External analog instruction 1: Digital instruction (parameter setting) 2: Digital instruction (Communication) 3: Internal multiple instruction
P04-01	Speed analog command inverting	

P04-02	Digital speed command value	1RPM
P04-03	Zero speed position clamping function	
P04-04	Zero speed position clamping velocity threshold	1RPM
P04-05	Alarm value	Setting the maximum speed value, exceeding the set value will alarm.
P04-06	Forward speed limit	Limit motor forward speed value
P04-07	Reverse speed limit	Limiting motor reverse speed value
P04-10	Zero velocity detection value	1RPM
P04-11	Rotation detection value	1RPM
P04-12	Speed uniform range	1RPM
P04-14	Acceleration time	1ms/1000rpm
P04-15	Deceleration time	1ms/1000rpm
P04-30	Internal velocity setting 1	Set up the internal command speed
P04-31	Internal velocity setting 2	Set up the internal command speed
P04-32	Internal velocity setting 3	Set up the internal command speed
P04-33	Internal velocity setting 4	Set up the internal command speed
P04-34	Internal velocity setting 5	Set up the internal command speed
P04-35	Internal velocity setting 6	Set up the internal command speed
P04-36	Internal velocity setting 7	Set up the internal command speed
P04-37	Internal velocity setting 8	Set up the internal command speed

P05-xx : Torque parameter

Parameter Code	Designation	Introductions
P05-00	Torque command source	0: External analog instruction 1: Digital instruction (parameter setting) 2: digital commands (communication) 3: Internal multiple instruction
P05-01	Torque analog command inverting	Used to adjust the torque direction: 0: Normal. 1: Reverse direction
P05-02	Torque mode speed limiting value	1RPM
P05-10	Internal positive direction torque limit	Range: 0-300.0 Unit:1% Limit motor forward torque, 100 means 1 times the rated torque, 300 said 3 times the rated torque.
P05-11	Internal negative direction torque limit	Range: 0-300.0 Unit:1% Limit motor reverse torque, 300 means 3 times the rated torque, 300

		said 3 times the rated torque.
P05-12	External positive direction torque limit	Range: 0-300.0 Unit:1% Limit motor forward torque, 100 means 1 times the rated torque, 300 said 3 times the rated torque.
P05-13	External negative direction torque limit	Range: 0-300.0 Unit:1% Limiti motor reverse torque, 300 means 3 times the rated torque, 300 said 3 times the rated torque.

P06-xx: I/O parameter

Parameter Code	Designation	Introductions
P06-00	DI1 input port effective level	0: Low level active 1: High level active 2: Rising edge active 3: Falling edge active 4: Both rise edge and fall edge active
P06-01	DI1 input port function selection	0: Invalid 1: Servo-ON input 2: Alarm clear input 3: Positive direction over-travel inhibition input 4: Negative direction over-travel inhibition input 5: Control mode switching mode 6: P operation command input 7: Positive direction torque limit switching input 8: Negative direction torque limit switching input 9: Gain switching input 10: Speed zero clamp input 11: Command pulse inhibition input 12: Encoder absolute value data requirements input 13: Selection 1 input of internal command speed 14: Selection 2 input of internal command speed 15: Selection 3 input of internal command speed 16: Position deviation counter clear input 17: Pole detection input 18: Electronic gear switching input
P06-02	DI2 input port effective level	Same with DI1 port active level instructions
P06-03	DI2 input port function selection	Same with DI1 port function instructions.
P06-04	DI3 input port effective level	Same with DI1 port active level instructions
P06-05	DI3 input port function selection	Same with DI1 port function instructions.
P06-06	DI4 input port effective	Same with DI1 port active level instructions

	level	
P06-07	DI4 input port function selection	Same with DI1 port function instructions.
P06-08	DI5 input port effective level	Same with DI1 port active level instructions
P06-09	DI5 input port function selection	Same with DI1 port function instructions.
P06-10	DI6 input port effective level	Same with DI1 port active level instructions
P06-11	DI6 input port function selection	Same with DI1 port function instructions.
P06-12	DI7 input port effective level	Same with DI1 port active level instructions
P06-13	DI7 input port selection function	Same with DI1 port function instructions.
P06-16	DI8 input port effective level	Same with DI1 port active level instructions
P06-17	DI8 input port function selection	Same with DI1 port function instructions.
P06-20	DO1 output port effective level	0: Active low 1: Active high
P06-21	DO1 output port selection function	0: Invalid 1: Servo alarm output 2: External brake release signal 3: Servo ready output 4: Positioning complete output 5: Positioning near output 6: At-speed output 7: Zero-speed detection output signal 8: Torque in-limit signal output 9: Speed in-limit signal output 10: Warning output 11: Command pulse input magnification switching output
P06-22	DO2 output port effective level	0: Active low 1: Active high
P06-23	DO2 output port function selection	Same with DO1 port function instructions.
P06-24	DO3 output port effective level	0: Active low 1: Active high
P06-25	DO3 output port function selection	Same with DO1 port function instructions.
P06-26	DO4 output port effective level	0: Active low 1: Active high
P06-27	DO4 output port function	Same with DO1 port function instructions.

	selection)	
P06-28	DO5 output port effective level	0: Active low 1: Active high
P06-29	DO5 output port function selection	Same with DO1 port function instructions.
P06-40	Input gain of speed command	Range: 10-2000, Unit: 1rpm/v Based on the voltage applied to the analog speed command, set up the conversion gain to motor command speed. Default setup of 500 represents 500rpm/1V
P06-41	Filter of speed command input	Range:0-64.00 Unit:1ms
P06-42	Offset of speed command	1V
P06-43	Input gain of torque command	Range: 0-100.0, Unit: 1% Based on the voltage applied to the analog torque command, set up the conversion gain to torque command. Default setup of 30.0 represents 30%/1V
P06-44	Filter of torque command input	Range:0-64.00 Unit:1ms
P06-45	Offset of torque command	1V

#### P08-xx : Advanced Function parameter

Parameter Code	Designation	Introductions
P08-01	Offline inertia auto-tuning mode selection	
P08-02	Maximum speed for inertia auto-tuning	Range: 10-2000, Unit:1rpm
P08-03	Time constant of acceleration to max speed for inertia auto-tuning	Range: 20-800, Unit:1ms
P08-04	Interval after an inertia auto-tuning	Range: 50-10000, Unit:1ms
P08-05	Motor revolution for an inertia auto-tuning	Rev
P08-11	Adaptive filter mode setup	0: Third, fourth notch filter parameters are no longer automatically updated, but allow manual input 1: 1 adaptive notch filters are available, and the parameters of the third notch filters are automatically updated, which can not be entered manually. 2: 2 adaptive notch filters are available, third, four notch filter parameters are updated automatically, and the manual input is not available. 3: Only to detect the resonance frequency

		4: Clear third, four notch filter parameters, return to the factory settings
P08-20	Time constant of torque filter	Range: 0-25.00, Unit:1ms Set up the time constant of the delay filter inserted in the torque command portion.
P08-25	Disturbance torque compensating gain	Range: 0-100.0, Unit:1% Set up 0 to 100% compensating gain against disturbance torque. After setting up P08-26, increase P08-25. The disturbance suppressing capability increases by increasing the gain, but it is associated with increasing volume of operation noise. This means that well balanced setup can be obtained by adjusting P08-25 and P08-26.
P08-26	Disturbance observer filter	Range: 0-25.00, Unit:1ms Set up the filter time constant according to the disturbance torque compensation.
P08-30	1st notch frequency	Range: 50-5000, Unit:1Hz Set the center frequency of the 1st notch filter The notch filter function will be invalidated by setting up this parameter to "5000".
P08-31	1st notch width selection	Range: 0-20 Set the width of notch at the center frequency of the 1st notch filter Higher the setup, larger the notch width you can obtain. Use with default setup in normal operation.
P08-32	1st notch depth selection	Range: 0-99 Set the depth of notch at the center frequency of the 1st notch filter Higher the setup, shallower the notch depth and smaller the phase delay you can obtain.
P08-33	2nd notch frequency	Range: 50-5000, Unit:1Hz Set the center frequency of the 2nd notch filter The notch filter function will be invalidated by setting up this parameter to "5000".
P08-34	2nd notch width selection	Range: 0-20 Set the width of notch at the center frequency of the 2nd notch filter Higher the setup, larger the notch width you can obtain. Use with default setup in normal operation.
P08-35	2nd notch depth selection	Range: 0-99 Set the depth of notch at the center frequency of the 2nd notch filter Higher the setup, shallower the notch depth and smaller the phase delay you can obtain.
P08-36	3rd notch frequency	Range: 50-5000, Unit:1Hz Set the center frequency of the 3rd notch filter The notch filter function will be invalidated by setting up this parameter to "5000".
P08-37	3rd notch width selection	Range: 0-20

		Set the width of notch at the center frequency of the 3rd notch filter Higher the setup, larger the notch width you can obtain. Use with default setup in normal operation.
P08-38	3rd notch depth selection	Range: 0-99 Set the depth of notch at the center frequency of the 3rd notch filter Higher the setup, shallower the notch depth and smaller the phase delay you can obtain.
P08-39	4th notch frequency	Range: 50-5000, Unit:1Hz Set the center frequency of the 4th notch filter The notch filter function will be invalidated by setting up this parameter to “5000”.
P08-40	4th notch width selection	Range: 0-20 Set the width of notch at the center frequency of the 4th notch filter Higher the setup, larger the notch width you can obtain. Use with default setup in normal operation.
P08-41	4th notch depth selection	Range: 0-99 Set the depth of notch at the center frequency of the 4th notch filter Higher the setup, shallower the notch depth and smaller the phase delay you can obtain.

### 8.3 Monitoring projects list

Display number	Display item	Description	Unit
d00.C.PU	Position Command pulse sum	This parameter can monitor Number of pulses sent by the user to the Servo drive, To confirm whether it's missing pulse	User units
d01.F.PU	Position feedback pulse sum	This parameter can monitor Number of pulses Servo drive feedback	User units
d02.E.PU	Position deviation number of pulses	This parameter can monitor the number of pulse delay in the operation of the Servo drive	User units
d03.C.PE	Position given pulse sum	This parameter can monitor Number of pulses sent by the user to the Servo drive, To confirm whether it's missing pulse	Encoder unit
d04.F.PE	Position feedback pulse sum	This parameter can monitor Number of pulses Servo drive feedback	Encoder unit
d05.E.PE	Position deviation pulse sum	This parameter can monitor the number of pulse delay in the operation of the Servo drive	Encoder unit
d06.C.Fr	Pulse command input frequency	This parameter can monitor the input frequency of pulse command	KPPS
d07.C.SP	speed reference		rpm



d08.F.SP	Actual motor speed	This parameter can monitor the rotational speed of servo motor	rpm
d09. C.tQ	Internal torque reference		%
d10. F.tQ	Torque feedback value	This parameter can monitor the torque of servo motor's run-time feedback	%
d11.AG.L	Average torque	This parameter can monitor the Average torque of servo motor	%
d12.PE.L	Peak torque	This parameter can monitor the Peak torque of servo motor	%
d13.oL	over load rate	This parameter can monitor the usage of servo motor's load	%
d14.rG	Regenerate Load Ratio		%
d16.I.Io	Monitored DI status	This parameter can monitor CN1 state of output port. On the vertical bar represents the light coupling cut-off, the vertical bar represents the light coupling conduction	Binary system
d17.o.Io	Monitored DO status	This parameter can monitor CN1 state of output port. On the vertical bar represents the light coupling conduction, the vertical bar represents the light coupling cut-off	Binary system
d18.AnG	Mechanical angle of the motor	this parameter can monitor the mechanical angle of motor, one circle is 360 degrees	0.1 degree
d19.HAL	Motor UVW Hall phase-sequence		
d20.ASS	Absolute encoder Single turn values		0-0xFFFF
d21.ASM	Absolute encoder multi-turn value		
d22.J-L	Inertia ratio		%
d23.dcp	Main loop voltage	This parameter can monitor the input voltage of main power supply	V
d24.Ath	Drive temperature	This parameter can monitor the temperature of the drive	°C
d25.tiE	Accumulative Total running time	This parameter can monitor drive's running time	S
d26.1.Fr	Resonance frequency 1		Hz
d28.2.Fr	Resonance frequency 2		Hz
d30.Ai1	Analog command 1 Input Voltage ( V_REF )	This parameter can monitor CN1 analog instruction input voltage value	0.01V
d31.Ai2	Analog command 2 Input Voltage ( T_REF )	This parameter can monitor CN1 analog instruction input voltage value	0.01V

## 8.4 Auxiliary function List

Serial No.	Display No.	Project function	operation
1	AF_JoG	JOG test run	<p>1. Press operation panel of the M button, switch to the auxiliary mode AF_XXX, the Up/Down buttons to AF_JOG, press the ENT key, enter the JOG mode. The default speed is 300 RPM.</p> <p>2. Press the Up button, the motor will forward at a speed of 300 r/min. Press the Down button, the motor reversal at a speed of 300 r/min</p> <p>3. Press ENT button, enter the edit menu. Through the Up key, the Down and the Left button to edit the speed, long press ENT button after editing, back into the JOG mode. The set speed is not saved when exit the JOG mode.</p> <p>4. Press M button to exit the JOG mode</p>
2	AF_run	Force enable run	<p>1. Press operation panel of the M button, switch to the auxiliary mode AF_XXX, the Up/Down buttons to AF_RUN, press the ENT key, enter this mode.</p> <p>2. Press the Up button, the shaft forward, long press the Up button, the motor speed will continue to improve; Press the Down button, the shaft reverse, long press the Down button, motor speed will continue to improve.</p> <p>3. Press M button to exit this mode</p>
3	AF_oF1	Analog input 1 offset automatic calibration ( VCMD )	<p>1. Press operation panel of the M button, switch to the auxiliary mode AF_XXX, the Up/Down buttons to AF_oF1, press the ENT key, enter this mode and will display clc.Ai1.</p> <p>2. Long press ENT key, until a " Finish " flashing, analog input 1 offset automatic calibration is completed</p> <p>3. Press M button to exit this mode</p>
4	AF_oF2	Analog input 2 offset automatic calibration ( TCMD )	Same with AF_oF1
5	AF_oF3	U , W Current offset automatic calibration	Same with AF_oF1
6	AF_En0	Absolute encoder fault clearance	<p>1. Press operation panel of the M button, switch to the auxiliary mode AF_XXX, the Up/Down buttons to AF_En0, press the ENT key, enter this mode and will display clc_Err.</p> <p>2. Long press ENT key, until a 'Finish' flashing, absolute encoder fault clearance is completed</p> <p>3. Press M button to exit this mode</p>
7	AF_En1	Absolute encoder multiturn value clearance	Same with AF_En0
8	AF_ini	Restore factory parameters	contact the manufacture

9	AF_Err	Error Records display	
10	AF_uEr	Version display	<p>1. Press operation panel of the M button, switch to the auxiliary mode AF_XXX, the Up/Down buttons to AF_uEr, press the ENT key. The Led will display the version.</p> <p>2. Press M button to exit this mode</p>
11	AF_unL	Relieve lock	<p>1. Press operation panel of the M button, switch to the auxiliary mode AF_XXX, the Up/Down buttons to AF_unL, press the ENT key. Then edit the lock level. 0: All parameter lock, 1: Lock P00-XX parameter, 2: Donot lock parameter.</p> <p>2. Press M button to exit this mode</p>
12	AF_Io	Force output port level	<p>1. Press operation panel of the M button, switch to the auxiliary mode AF_XXX, the Up/Down buttons to AF_Io, press the ENT key.</p> <p>2. Press M button to exit this mode, Output output port to restore to its original state</p>

## Chapter9 Fault Analysis and treatment

### 9.1 Failure alarm information list

Alarm Type	Alarm Code	Alarm contents
hardware fault	AL.051	Eeprom parameter abnormal
	AL.052	Programmable Logic configuration fault
	AL.053	Initialization Failed
	AL.054	System abnormal
	AL.060	Product model Select fault
	AL.061	Product matching fault
	AL.062	Parameter storage fault
	AL.063	over current checkout
	AL.064	Servo power on , Self-Test find out the output short circuit fault
	AL.065	servo unit built-in Fan stop
	AL.066	servo unit control power supply low voltage
	AL.070	AD Sample fault1
	AL.071	Current sample fault
	AL.100	Parametric combination abnormal
	AL.101	AI Setting fault
	AL.102	DI distributing fault
	AL.103	DO distributing fault
	AL.105	Electronic gear Configuration error
	AL.106	Frequency splitting pulse output Setting abnormal
	AL.110	Need to power-on again after the parameter setting
AL.120	Servo ON Instruction invalid	
operational faults	AL.400	power line lack Phase
	AL.401	Under voltage
	AL.402	Over voltage
	AL.410	Overload(instantaneous Maximum load)
	AL.411	Drive overload
	AL.412	Motor overload ( Continuous maximum load )
	AL.420	Over speed
	AL.421	Lose Control check out
	AL.422	runaway fault
	AL.425	AI collect sample over voltage
	AL.430	Regeneration of Abnormal
	AL.431	Regeneration of overload
	AL.432	Regeneration of Short circuit Open circuit
	AL.435	Stroke current Limited overload resistance
	AL.436	DB overload
	AL.440	Radiator overheat

	AL.441	Motor overheat fault
	AL.500	Output frequency division over speed
	AL.501	Position deviation is too large
	AL.502	Full closed loop encoder position and Motor position error are too large
	AL.505	Pulse Command input pulse abnormal
	AL.550	Inertia identification failure fault
	AL.551	back to origin Point timeout fault
	AL.552	Angle Identification failure fault
Encoder fault	AL.600	Encoder output power short circuit fault
	AL.610	Incremental encoder gets out of line
	AL.611	Incremental encoder Z signal loss
	AL.620	Absolute Encoder gets out of line
	AL.621	Read and write motor encoder EEPROM parameter abnormal
	AL.622	motor encoder EEPROM data parity error
	AL.640	Absolute encoder overspeed
	AL.641	Absolute encoder overheat
	AL.642	Absolute encoder Battery low voltage alarm
	AL.643	Absolute encoder Battery low voltage fault
	AL.644	Absolute encoder multi-turn fault
	AL.645	Absolute encoder multi-turn overflow fault
	AL.646	Absolute encoder communication error 1
	AL.647	Absolute encoder count error 2
	AL.648	Absolute encoder communication error 3
	AL.649	Absolute encoder communication error 4
	AL.650	Absolute encoder communication error 5
	AL.651	Absolute encoder communication error 6
AL.652	Absolute encoder multi-turn Multiple faults	
Warning	AL.900	Location deviation is too large
	AL.901	When servo ON, Location deviation is too large
	AL.910	Motor overload
	AL.912	Drive overload
	AL.920	Regeneration of overload
	AL.921	DB overload
	AL.925	External regeneration bleeder resistor is too small
	AL.930	Absolute encoder's battery Fault
	AL.941	Need to power-on again after Parameters changing
	AL.942	Write EEPROM frequent warnings
	AL.950	Over run Warning
	AL.951	Absolute encoder angle initialization warning
	AL.971	Under voltage warning
	AL.990	Radiator overheat warning
	AL.991	Input phase loss warning

## 9.2 Causes and Treatment of fault alarm

### AL51 : EEPROM parameter abnormal

Causes of fault alarm	Fault alarm checking	Disposal measures
servo unit EEPROM data abnormal	Check connection	Correct connection , reconnect power, If always appear, then change a drive

### AL52 : Programmable logical configuration fault

Causes of fault alarm	Fault alarm checking	Disposal measures
Master control MCU power-on initialization exception, Serial port baud rate setting is too high	Check connections, Check the baud rate of serial communication parameters P00-21	Reduce the baud rate of Serial Communication, If always appear, then change a drive

### AL53 : Initialization Failed

Causes of fault alarm	Fault alarm checking	Disposal measures
Master control MCU power-on initialization failed	check connections reconnect power	If always appear, then change a drive

### AL54 : System error

Causes of fault alarm	Fault alarm checking	Disposal measures
Master control MCU operation abnormal	check connections reconnect power	If always appear, then change a drive

### AL60 : Product model selection fault

Causes of fault alarm	Fault alarm checking	Disposal measures
Product parameter setting does not match the actual hardware	Check the product parameters and hardware models	correct product settings , if it always appears, Contact the manufacturer

### AL61 : Products matching fault

Causes of fault alarm	Fault alarm checking	Disposal measures
servo unit and servo motor does not match	Detect whether the servo unit can support the motor	Replace the matching motor and servo units

### AL63 : Overcurrent detection

Causes of fault alarm	Fault alarm checking	Disposal measures
The servo control unit power current is too high	U,V,W wiring whether is short circuit	Correct connection , If always appear, then change a drive

### AL66 : Servo Unit controls the power supply voltage is low

Causes of fault alarm	Fault alarm checking	Disposal measures
Control power supply L,N power voltage is too low	check connections Measure L, N , whether the voltage is lower than 140VAC	Correct connection , If always appear, then change a drive

### AL.71 : Current collect sample fault

Causes of fault alarm	Fault alarm checking	Disposal measures
abnormal collect sample data in	check connections whether is	Correct connection , If always

current sensor	correct	appear, then change a drive
----------------	---------	-----------------------------

AL.103 : DI allocation Fault

Causes of fault alarm	Fault alarm checking	Disposal measures
At least have 2 functions of input port ,parameter selections are the same	Check port input function select parameters	Set the correct parameters, Reconnect power to the drive

AL.106 : Frequency division pulse output settings abnormal

Causes of fault alarm	Fault alarm checking	Disposal measures
Frequency division pulse output settings out of range	check frequency division pulse output setting parameters P03-22 , P03-23 P03-25	Correct setting frequency division pulse output parameters. Incremental encoder P03-22<P03-23 Absolute encoder P03-25<32768 Reconnect power to the drive

AL.110 : Need to reconnect power after set parameters

Causes of fault alarm	Fault alarm checking	Disposal measures
Need to reconnect power to take effect After Servos Set parameter	Reconnect power to the drive	Reconnect power to the drive

AL.120 : Servo ON Instruction invalid alert

Causes of fault alarm	Fault alarm checking	Disposal measures
servo ON instruction executed accessibility function R,S,T Voltage ports do not supply power	check connections	Correct connection, Reconnect power to the drive

AL.400 : Power line lose phase

Causes of fault alarm	Fault alarm checking	Disposal measures
Drive power cord error	Check the power cord connected to the drive	According to manual's the wiring instructions ,reseat the power cord

AL.401 : Undervoltage

Causes of fault alarm	Fault alarm checking	Disposal measures
The main circuit input voltage lower than the rated voltage value or No input voltage	Check main circuit of input R,S,T Voltage wiring whether is correct and what is the value of voltage volts	Make sure the wiring is correct, Use the correct voltage source or connect with regulator in Series

AL.402:Overvoltage

Causes of fault alarm	Fault alarm checking	Disposal measures
Main loop Input voltage is higher than the rated voltage	Test the input voltage of main loop with a voltmeter is correct	Use the correct voltage source or Series connection regulator
Drive hardware fault	After confirm the correct input voltage still overvoltage alarm	Please return back to the dealer or Original factory service

No connection with Regenerative Resistor or connect with wrong Regenerative Resistor	Confirm P00-30 setting is 0 or 1	Correct setting and regeneration of external resistors
--	----------------------------------	--

AL.412 : Motor overload ( Continuous maximum load )

Causes of fault alarm	Fault alarm checking	Disposal measures
Over drive rated load continuous use	Can monitor Through monitoring mode d13.oL.	Change motor or reduce the load
Control System parameters are set improperly	1、 Mechanical system is installed or not 2、 Acceleration setting constants is too fast 3、 Gain parameters are set correctly or not	1、 Adjust the gain control circuits 2、 slow down the acceleration and deceleration setting time
Motor wiring error	Check U、 V、 W wiring	Correct wiring

AL.420 : Over speed

Causes of fault alarm	Fault alarm checking	Disposal measures
Input speed Command is too high	check input signals whether is working properly or not by signal detection meter	Adjust the frequency of the input signal
over Speed determine the parameter setting is incorrect	Check P04-05 ( over speed alarm value )Whether it setting reasonable	Setting P04-05 ( over speed alarm value ) correctly

AL.421 : Lose Control detected

Causes of fault alarm	Fault alarm checking	Disposal measures
Motor power line U,V,W wiring error	Check wiring	Correct wiring
Motor parameter settings are not correct	Check P00-05 and encoder parameter settings are correct or not	Set the parameters correctly

AL.430 :regeneration exception AL.431 :regeneration overload AL.432 :Regeneration short circuit , open loop

Causes of fault alarm	Fault alarm checking	Disposal measures
select wrong Regenerative resistor or No connect with external regeneration resistance	Check the connection status of regenerative resistor	If the connection is correct, Please return back the drive to the original factory service
parameter setting error	Please Confirm P00-30 , P00-31 , P00-32 parameter setting	Setting Parameter Values correctly

AL.501:Location deviation is too large

Causes of fault alarm	Fault alarm checking	Disposal measures
Location deviation is too large ,parameter setting is too small	Confirm P03-15 ( Location deviation setting is too large ) parameter setting	increaseP03-15 ( Position deviation setting is too large ) setting value
Gain value setting is too small	Confirm the gain parameter setting whether is reasonable	Properly readjust the gain type parameter



Internal torque limit value setting is too small	Confirm the internal torque limit value	Correctly readjust the internal torque limit value
External load is too large	Check the external load	Decrease the external load or change a large power motor

AL.505 : P Command input pulse abnormal

Causes of fault alarm	Fault alarm checking	Disposal measures
Pulse command frequencies higher than the rated input frequency	check input frequency whether is higher than rate input frequency by frequency survey meter	Correctly setting the input pulse frequency

AL.600 : Encoder Output power supply fault

Causes of fault alarm	Fault alarm checking	Disposal measures
Encoder power supply wiring errors	Check the encoder power supply +5V and GND if is Opposite connecting	Correct wiring

AL.610 : Incremental Encoder gets out of line

Causes of fault alarm	Fault alarm checking	Disposal measures
Incremental encoder HallU, HallV, HallW signal abnormal	Check the encoder connection	Correct wiring

AL.620 : Bus-based Encoder gets out of line

Causes of fault alarm	Fault alarm checking	Disposal measures
Bus-based Encoder communication failure	Check the encoder connection	Correct wiring

AL.640:Bus-based Encoder over speed

Causes of fault alarm	Fault alarm checking	Disposal measures
Bus-based encoder value more than 6000rpm	Check encoder connection, Confirm the encoder shielded cable is connected properly	reduce the speed

AL.642, AL.643 : Bus-based Encoder battery fault

Causes of fault alarm	Fault alarm checking	Disposal measures
when Bus-based Encoder setting is multiturn value, External battery voltage is too low	Check the voltage of encoder external battery ,Confirm it more than 3.0V	replace battery

AL.645 : Bus-based Encoder multiturn overflow errors

Causes of fault alarm	Fault alarm checking	Disposal measures
Set P00-09 to 1 Bus-based Encoder Rotation number is out of range		Can use the command AF_En1 Clear up multi - circle values

AL.647 : Bus-based encoder Count abnormal

Causes of fault alarm	Fault alarm checking	Disposal measures
Separate encoder installation	Check the encoder	Properly install encoders

position deviation is too large		
---------------------------------	--	--