

EXTERNAL ESTOP & TOOL CHANGE

This control circuit will prevent the spindle and servo motors from starting when Estop is pressed or manual change tool is requested. For soft estop it uses the enable pin of motion component it also uses a redundant hardwired external circuit Estop. The interface between the software Estop and the hardwired circuit is done through an interface board, using 2 digital inputs and 2 digital outputs.

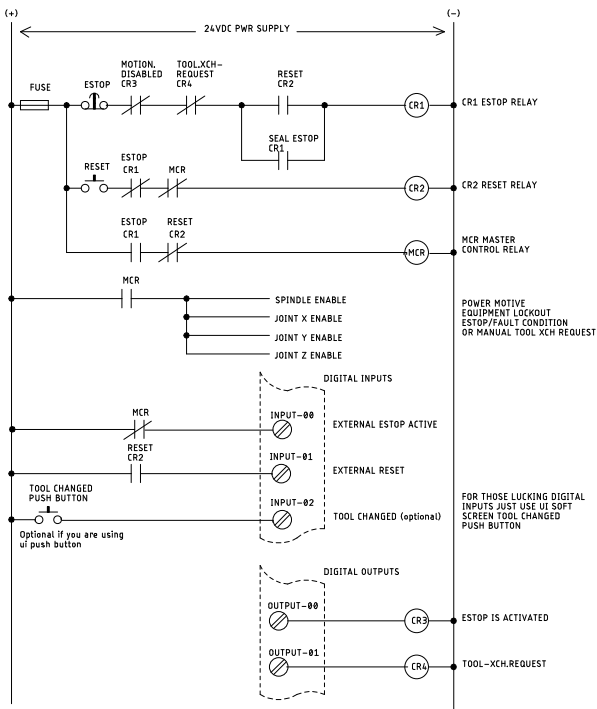

POSTGUI HAL BLOCK DIAGRAM

