



---

---

*SERVO DRIVE*

---

---

# UM Series DC Servo Control

Installation & Operating Manual

# Table of Contents

---

<b>Section 1</b>	
<b>General Information</b> .....	1-1
Limited Warranty .....	1-1
Product Notice .....	1-2
Safety Notice .....	1-2
<b>Section 2</b>	
<b>Product Overview</b> .....	2-1
<b>Section 3</b>	
<b>Receiving and Installation</b> .....	3-1
Receiving & Inspection .....	3-1
Location Considerations .....	3-1
Mechanical Installation .....	3-1
Electrical Installation .....	3-2
Electrical Noise Considerations .....	3-2
Input Power Transformer .....	3-4
Power Wiring .....	3-5
Signal Wiring .....	3-6
Optional Input Connections .....	3-8
<b>Section 4</b>	
<b>Adjustments and Start-Up</b> .....	4-1
Overview .....	4-1
Initial Settings .....	4-1
Start-Up Velocity Mode .....	4-2
Start-Up Torque Mode .....	4-3
Test Points .....	4-3
<b>Section 5</b>	
<b>Troubleshooting</b> .....	5-1
Overview .....	5-1
Maintenance .....	5-1
Initial Checks .....	5-1
Reset the Servo Control .....	5-1
<b>Section 6</b>	
<b>Specifications &amp; Product Data</b> .....	6-1
<b>Appendix A</b>	
<b>Personality Module</b> .....	A-1
Jumper and Personality Module Settings .....	A-1
Personality Module Current Settings .....	A-1
Peak and Continuous Current Levels .....	A-2
Record of “Set Up” Configuration .....	A-3



# Section 1

## General Information

---

Copyright Baldor © 1999. All rights reserved.

This manual is copyrighted and all rights are reserved. This document may not, in whole or in part, be copied or reproduced in any form without the prior written consent of Baldor.

Baldor makes no representations or warranties with respect to the contents hereof and specifically disclaims any implied warranties of fitness for any particular purpose. The information in this document is subject to change without notice. Baldor assumes no responsibility for any errors that may appear in this document.

### **Limited Warranty**

For a period of two (2) years from the date of original purchase, BALDOR will repair or replace without charge controls and accessories which our examination proves to be defective in material or workmanship. This warranty is valid if the unit has not been tampered with by unauthorized persons, misused, abused, or improperly installed and has been used in accordance with the instructions and/or ratings supplied. This warranty is in lieu of any other warranty or guarantee expressed or implied. BALDOR shall not be held responsible for any expense (including installation and removal), inconvenience, or consequential damage, including injury to any person or property caused by items of our manufacture or sale. (Some states do not allow exclusion or limitation of incidental or consequential damages, so the above exclusion may not apply.) In any event, BALDOR's total liability, under all circumstances, shall not exceed the full purchase price of the control. Claims for purchase price refunds, repairs, or replacements must be referred to BALDOR with all pertinent data as to the defect, the date purchased, the task performed by the control, and the problem encountered. No liability is assumed for expendable items such as fuses.

Goods may be returned only with written notification including a BALDOR Return Authorization Number and any return shipments must be prepaid.

---

## **Product Notice**

Intended use:

These drives are intended for use in stationary ground based applications in industrial power installations according to the standards EN60204 and VDE0160. They are designed for machine applications that require variable speed controlled three phase brushless AC motors.

These drives are not intended for use in applications such as:

- Home appliances
- Medical instrumentation
- Mobile vehicles
- Ships
- Airplanes

Unless otherwise specified, this drive is intended for installation in a suitable enclosure. The enclosure must protect the control from exposure to excessive or corrosive moisture, dust and dirt or abnormal ambient temperatures. The exact operating specifications are found in Section 6 of this manual.

The installation, connection and control of drives is a skilled operation, disassembly or repair must not be attempted.

In the event that a control fails to operate correctly, contact the place of purchase for return instructions.

## **Safety Notice:**

This equipment contains high voltages. Electrical shock can cause serious or fatal injury. Only qualified personnel should attempt the start-up procedure or troubleshoot this equipment.

This equipment may be connected to other machines that have rotating parts or parts that are driven by this equipment. Improper use can cause serious or fatal injury. Only qualified personnel should attempt the start-up procedure or troubleshoot this equipment.

- System documentation must be available at all times.
- Keep non-qualified personnel at a safe distance from this equipment.
- Only qualified personnel familiar with the safe installation, operation and maintenance of this device should attempt start-up or operating procedures.
- Always remove power before making or removing any connections to this control.

**PRECAUTIONS:** Classifications of cautionary statements.

 **WARNING:** Indicates a potentially hazardous situation which, if not avoided, could result in injury or death.

 **Caution:** Indicates a potentially hazardous situation which, if not avoided, could result in damage to property.

---

**PRECAUTIONS:**

- ⚠ WARNING:** Do not touch any circuit board, power device or electrical connection before you first ensure that power has been disconnected and there is no high voltage present from this equipment or other equipment to which it is connected. Electrical shock can cause serious or fatal injury.
- ⚠ WARNING:** Be sure that you are completely familiar with the safe operation of this equipment. This equipment may be connected to other machines that have rotating parts or parts that are controlled by this equipment. Improper use can cause serious or fatal injury.
- ⚠ WARNING:** Be sure all wiring complies with the National Electrical Code and all regional and local codes or CE Compliance. Improper wiring may cause a hazardous condition.
- ⚠ WARNING:** Be sure the system is properly grounded before applying power. Do not apply AC power before you ensure that grounds are connected. Electrical shock can cause serious or fatal injury.
- ⚠ WARNING:** Do not touch any electrical component for at least five (5) minutes after AC power is disconnected to allow capacitors to discharge. Electrical shock can cause serious or fatal injury.
- ⚠ WARNING:** Improper operation of control may cause violent motion of the motor shaft and driven equipment. Be certain that unexpected motor shaft movement will not cause injury to personnel or damage to equipment. Peak torque of several times the rated motor torque can occur during control failure.
- ⚠ WARNING:** Motor circuit may have high voltage present whenever AC power is applied, even when motor is not rotating. Electrical shock can cause serious or fatal injury.
- ⚠ WARNING:** If a motor is driven mechanically, it may generate hazardous voltages that are conducted to its power input terminals. The enclosure must be grounded to prevent a possible shock hazard.
- ⚠ WARNING:** When operating a motor with no load coupled to its shaft, remove the shaft key to prevent injury if it were to fly out when the shaft rotates.
- ⚠ WARNING:** The motor shaft will rotate during the autotune procedure. Be certain that unexpected motor shaft movement will not cause injury to personnel or damage to equipment.
- ⚠ WARNING:** The user must provide an external hard-wired emergency stop circuit to disable the control in the event of an emergency.
- ⚠ Caution:** Suitable for use on a circuit capable of delivering not more than the RMS symmetrical short circuit amperes listed here at rated voltage.

<u>Horsepower</u>	<u>RMS Symmetrical Amperes</u>
1–50	5,000
- ⚠ Caution:** To prevent equipment damage, be certain that the input power has correctly sized protective devices installed as well as a power disconnect.

Continued on next page.

- 
- ⚠ Caution:** Avoid locating control immediately above or beside heat generating equipment, or directly below water or steam pipes.
  - ⚠ Caution:** Avoid locating control in the vicinity of corrosive substances or vapors, metal particles and dust.
  - ⚠ Caution:** For UL installations, do not connect any resolver cable shields to the motor frame. At a minimum, resolver signal integrity will be compromised and damage to the control may result.
  - ⚠ Caution:** Do not connect AC power to the control terminals U, V and W. Connecting AC power to these terminals may result in damage to the control.
  - ⚠ Caution:** Baldor recommends not using “Grounded Leg Delta” transformer power leads that may create ground loops and degrade system performance. Instead, we recommend using a four wire Wye.
  - ⚠ Caution:** Logic signals are interruptible signals; these signals are removed when power is removed from the drive.
  - ⚠ Caution:** Controls are intended to be connected to a permanent main power source, not a portable power source. Suitable fusing and circuit protection devices are required.
  - ⚠ Caution:** The safe integration of the drive into a machine system is the responsibility of the machine designer. Be sure to comply with the local safety requirements at the place where the machine is to be used.
  - ⚠ Caution:** Controls must be installed inside an electrical cabinet that provides environmental control and protection. Installation information for the drive is provided in this manual. Motors and controlling devices that connect to the drive should have specifications compatible to the drive.
  - ⚠ Caution:** Violent jamming (stopping) of the motor shaft during operation may damage the motor and control.
  - ⚠ Caution:** Do not tin (solder) exposed wires. Solder contracts over time and may cause loose connections.
  - ⚠ Caution:** Electrical components can be damaged by static electricity. Use ESD (electro-static discharge) procedures when handling this control.
  - ⚠ Caution:** Ensure that motor and tachometer wires are properly connected. Incorrect installation may result in improper rotation or incorrect commutation.

## Section 2

# Product Overview

---

### Overview

The Baldor UM series high frequency DC servo control provides performance with attention to economy. It is designed to operate a wide variety of Baldor DC brush type permanent magnet servo motors. The UM series control is a key component in motion control applications and provides 1 to six axes control. It precisely controls both the current and velocity at the motor. Several configurations are available to suit most application requirements.

Current mode operation is useful in applications where commanded motor torque must be proportional to a voltage at the signal input. Since torque is proportional to motor current, constant current must be provided to the motor to develop constant torque. The current mode operation differs from velocity mode operation in that the velocity loop is basically disabled (gain is reduced from 6000 A/V to approximately 6 A/V). The current loop controls the output current proportional to the input voltage (VCS).

Typical applications requiring current mode operation are:

- Web controls
- Brake applications
- Bolt tightening

Current mode operation is also useful if a Baldor motion controller is precisely controlling the velocity loop. In this configuration tachometer feedback is not required.

**“UM” and “LD” series servo circuit boards are not interchangeable.**

### Motors

Baldor servo controls are compatible with many motors from Baldor and other manufacturers. Baldor compatible motors include:

- M2200 –Series motors
- M3300 –Series motors
- M4000 –Series motors
- M4500 –Series motors

Refer to the BR1202 catalog or contact your local Baldor distributor or sales representative for assistance with motor sizing and compatibility.

### Features

- Fault Protection Latch or Current Foldback
- 20kHz “Inaudible” Switching
- Test Points to aid during setup
- Jumper Selections to quickly tailor an application
- Standard  $\pm 10$ VDC command input signal
- Velocity / Current Configuration
- Decoupled current sense (monitor absolute or actual value)
- Left and Right Limit – over travel limit
- Interlock (disable output to motor)
- Pushbutton Reset

### Status Indicators

- External Reset Input
- Voltage Error (VE)
- Excess Current (EC)
- Thermal Protection (EC)
- Ground Fault (GF)
- Surge Current (SC) and Short Circuit Protection
- Logic Voltage Status (MV, PV) or (-15V, +15V)
- Bus Voltage Status (PB) or (BUS)
- AC Input Voltage Status (AC)



---

## **Functional Description**

The servo control consists of a power amplifier, a velocity control amplifier, and fault logic circuitry.

### **Power Amplifier**

The power section of a PWM bridge normally acts as a low output impedance voltage source. However, if an analog signal representing motor current is applied to the input of the amplifier and a current command is present, the impedance of the PWM bridge then becomes high. These high impedance bridges exhibit a unique characteristic referred to as current sourcing. That is, motor current (and therefore motor torque) becomes proportional to commanded input current.

#### **Current Sense Coupler**

The current sense coupler of the power amplifier serves as the current loop feedback mechanism. The unit isolates the high voltage motor signal from the low voltage control circuitry.

#### **Switching Configuration**

The power amplifier contains a transistor bridge output stage that conditions the voltage and current that is applied to the motor.

### **Velocity Control Amplifier**

The high gain front end velocity control amplifier accepts a speed command (Signal) and a tachometer voltage (Tach). The VCA clamped error signal (C adjustment) is applied to the power amplifier as a current command.

### **Fault Logic Circuitry**

The Fault Logic Circuitry functions are described in the following paragraphs.

#### **Excess Current Limit**

A comparator checks motor current for overload conditions beyond rated output. If the comparator is tripped, it disables the control, lights the EC indicator, and pulls the interlock line "low" (if P4 is in latch position). The control must be reset.

#### **Surge Current Sensor**

The surge current sensor pulls the interlock line low internally if the peak output current is exceeded. The control must be reset.

#### **Overheat Sensor**

If the thermal switch on the heatsink indicates the temperature exceeded a preset level, the switch sets the EC (Excess Current) latch, which operates the EC fault indicator. The fault is cleared when the heat sink temperature decreases.

#### **Left Limit, Right Limit**

Limit switches are typically mounted on machinery to restrict the load from moving into over-travel conditions. When a limit switch is activated, travel in that direction is not allowed. However, the motor can be reversed to move the load.

#### **Decoupled Current Sense (DCS)**

The Decoupled Current Sense (DCS) pin is isolated from the high voltage motor lines. Therefore, motor current is evaluated safely by connecting an oscilloscope or voltmeter to the DCS pin of the input connector and common (TPI).

#### **Tachometer Filter**

The tachometer filter rejects tachometer commutator noise by reducing the tach path bandwidth so that the high gain velocity control amplifier can be responsive yet reject tachometer noise.

## Section 3

# Receiving and Installation

---

**Receiving & Inspection** Baldor Controls are thoroughly tested at the factory and carefully packaged for shipment. When you receive your control, there are several things you should do immediately.

1. Observe the condition of the shipping container and report any damage immediately to the commercial carrier that delivered your control.
2. Remove the control from the shipping container and remove all packing materials. The container and packing materials may be retained for future shipment.
3. Verify that the part number of the control you received is the same as the part number listed on your purchase order.
4. Inspect the control for external physical damage that may have been sustained during shipment and report any damage immediately to the commercial carrier that delivered your control.
5. If the control is to be stored for several weeks before use, be sure that it is stored in a location that conforms to published storage humidity and temperature specifications stated in this manual.

**Location Considerations** The location of the control is important. Installation should be in an area that is protected from direct sunlight, corrosives, harmful gases or liquids, dust, metallic particles, and vibration. Exposure to these can reduce the operating life and degrade performance of the control.

Several other factors should be carefully evaluated when selecting a location for installation:

1. Clearance must be provided for air flow.
2. **Altitude derating.** Up to 3300 feet (1000 meters) no derating required. Derate the continuous and peak output current by 3% for each 1000 feet (305 meters) above 3300 feet up to 10,000 feet (3050 meters) maximum.
3. **Temperature derating.** From 0°C to 40°C ambient no derating required. Above 40°C, derate the continuous and peak output current by 2.5% per °C above 40°C. Maximum ambient is 50°C.

**Mechanical Installation** See Figure 3-1.

Refer to Section 7 for the dimensions and layout of the chassis. Layout and drill the four holes for mounting the chassis. Cut any openings in the cabinet for wiring. debur all edges.

1. Mount the control to the mounting surface. The control must be securely fastened to the mounting surface by the four control mounting holes.
2. Use one of the mounting holes to attach a ground wire to earth or the central system ground.
3. Open the servo control card shipping box and remove each circuit board. Remove the protective bag and install each board on the chassis using the two phillips head machine screws (module mounting screws) located in each slot position of the chassis. Tighten each screw using a long phillips screwdriver.
4. Locate the large bus connector of the prewired harness and connect it to J6.
5. Locate the smaller connector of the same harness and connect it to J5.

Note: Be careful not to bend connector pins and be sure pins are aligned before pushing onto the connector.

**Figure 3-1 Installing the Circuit Boards**

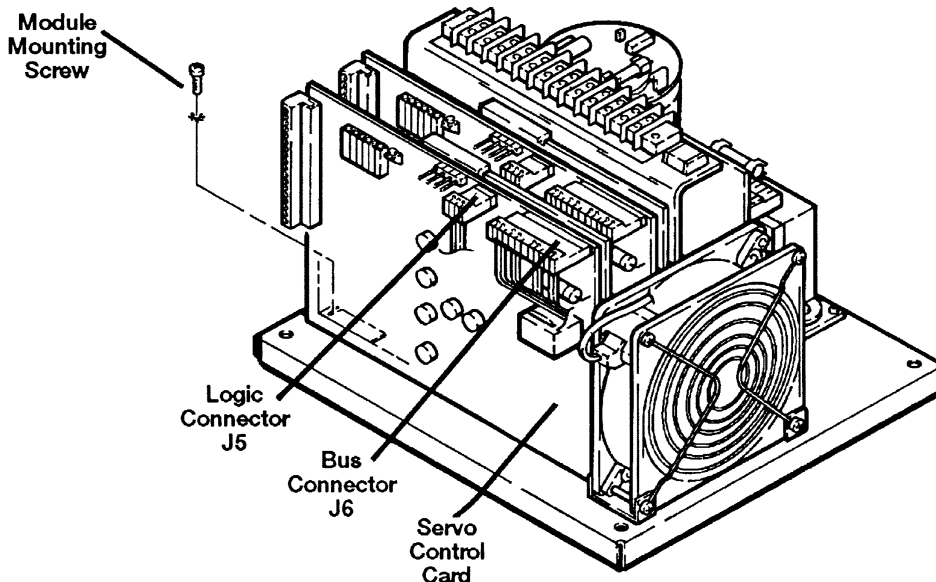

### **Electrical Installation**

All interconnection wires between the control, AC power source, motor, host control and any operator interface stations should be in metal conduits. Use listed closed loop connectors that are of appropriate size for wire gauge being used. Connectors are to be installed using crimp tool specified by the manufacturer of the connector. Only class 1 wiring should be used.

All wiring must be performed to the requirements of the National Electrical Code (NEC) and local requirements.

### **Electrical Noise Considerations**

All electronic devices are vulnerable to significant electronic interference signals (commonly called "Electrical Noise"). At the lowest level, noise can cause intermittent operating errors or faults. From a circuit standpoint, 5 or 10 millivolts of noise may cause detrimental operation. For example, analog speed and torque inputs are often scaled at 5 to 10VDC maximum with a typical resolution of one part in 1,000. Thus, noise of only 5 mV represents a substantial error.

At the extreme level, significant noise can cause damage to the drive. Therefore, it is advisable to prevent noise generation and to follow wiring practices that prevent noise generated by other devices from reaching sensitive circuits. In a control, such circuits include inputs for speed, torque, control logic, and speed and position feedback, plus outputs to some indicators and computers.

### **Relay and Contactor Coils**

Among the most common sources of noise are the coils of contactors and relays. When these highly inductive coil circuits are opened, transient conditions often generate spikes of several hundred volts in the control circuit. These spikes can induce several volts of noise in an adjacent wire that runs parallel to a control-circuit wire. Figure 3-2 illustrates noise suppression for AC and DC relay coils.

---

**Figure 3-2 AC and DC Coil Noise Suppression**

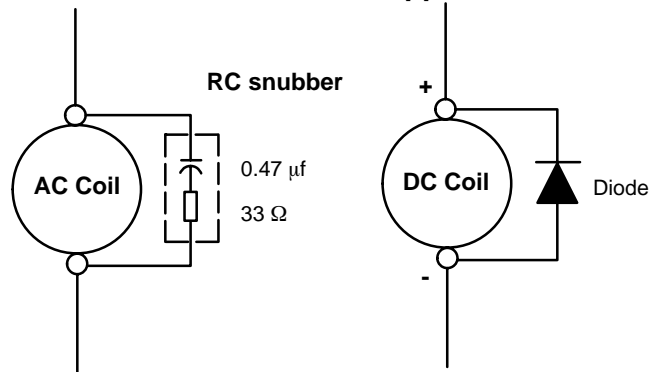

### **Control Enclosures**

Motor controls mounted in a grounded enclosure should also be connected to earth ground with a separate conductor to ensure best ground connection. Often grounding the control to the grounded metallic enclosure is not sufficient. Usually painted surfaces and seals prevent solid metallic contact between the control and the panel enclosure. Likewise, conduit should never be used as a ground conductor for motor power wires or signal conductors.

### **Special Motor Considerations**

Motor frames must also be grounded. Motors must be grounded directly to the control and plant ground with as short a ground wire as possible. Capacitive coupling within the motor windings produces transient voltages between the motor frame and ground. The severity of these voltages increases with the length of the ground wire.

### **Analog Signal Wires**

Analog signals generally originate from speed and torque controls, plus DC tachometers and process controllers. Reliability is often improved by the following noise reduction techniques:

- Use shielded twisted-pair wires with the shield grounded at the drive end only.
- Route analog signal wires away from power or control wires (all other wiring types).
- Cross power and control wires at right angles (90°) to minimize inductive noise coupling.

## Input Power Transformer

The UM series servo control requires an external isolation transformer that provides an ungrounded AC power source.

- UM controls with a 100VDC bus require 70VAC<sub>RMS</sub> nominal.
- UM controls with a 150VDC bus require 105VAC<sub>RMS</sub> nominal.

To determine the proper size transformer (kVA rating), use this guideline:  
(Rated Continuous Current) X (Bus Voltage) X (# of Axes) = kVARating

### Example:

UM4-100-2 with 3 UM3015HS-100  
(15A) X (100VDC) X (3 Axes) = 4.5kVA

This method of transformer sizing is safe and it may be a little oversized. In most cases, servo controls are not continuously operating at full voltage and current all the time. It is common practice to use a smaller transformer that is sized just larger than to actual continuous voltage and current consumed by the motor(s).

Baldor has several transformers to suit your application. Identification of these transformers is shown in Figure 3-3. ±5% output voltage taps are provided to accommodate variations in incoming AC voltage.

**Figure 3-3 Input Transformer Identification**

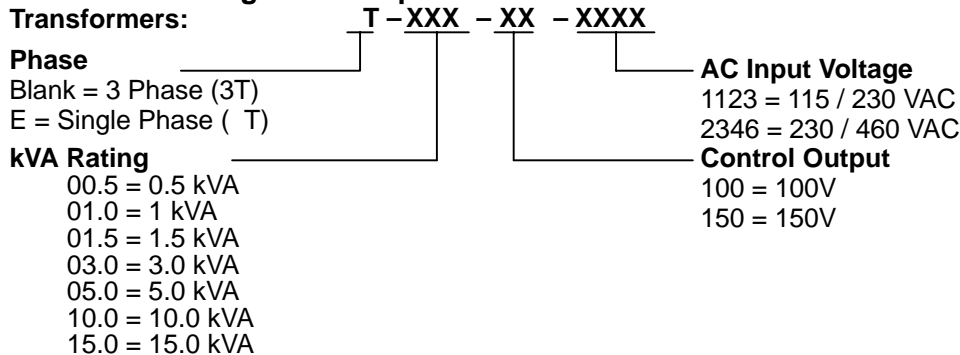

**Table 3-1 Current and Voltage Rating By Control**

Control # of Motors	Input Voltage		70 VAC <sup>†</sup>	105 VAC <sup>†</sup>	AC Input Power Wire Size	
	Bus Voltage		100 VDC	150 VDC		
	Output Current Amps		Catalog Number	Catalog Number	AWG	mm <sup>2</sup>
One	6	15	UM2-100-1-10S	-	14	2.5
	15	30	UM2-100-1-01S	UM2-150-1-01S	12	2.5
Two	6	15	UM2-100-1-20S	-	14	2.5
	15	30	UM2-100-1-02S	UM2-150-1-02S	12	2.5
Three	6	15	UM4-100-2-30S	-	14	2.5
	15	30	UM4-100-2-03S	UM4-150-2-03S	12	2.5
Four	6	15	UM4-100-2-40S	-	14	2.5
	15	30	UM4-100-2-04S	UM4-150-2-04S	12	2.5
Five	6	15	UM6-100-2-50S	-	14	2.5
	15	30	UM6-100-2-05S	UM6-150-2-05S	12	2.5
Six	6	15	UM6-100-2-60S	-	14	2.5
	15	30	UM6-100-2-06S	UM6-150-2-06S	12	2.5

Note: <sup>†</sup> An isolation transformer is required to provide these voltages.

**Power Wiring** Be sure to use the correct size wire for each connection. AC Input Power wires, Motor and the main ground wire should be the size stated in Table 3-1. The logic and fan power lines should be 16 AWG.

**1 to 4 Axis Procedure** (Refer to Figure 3-4).

1. Be sure all voltage sources are turned off.
2. Connect AC power from the isolation transformer to AC Bus Power Input L1, L2, L3. Single phase use L1, L2.
3. Connect 115VAC power to logic and fan input terminals 11 and 12 of the terminal block.

**For UMX-XXX-5 or UMX-XXX-6, use 240 VAC 50 Hz nominal to supply logic and fan power.**

4. Connect the negative and positive wires from each servo motor to the terminal block as shown in the figure.

**Figure 3-4 1 to 4 Axis Power Wiring**

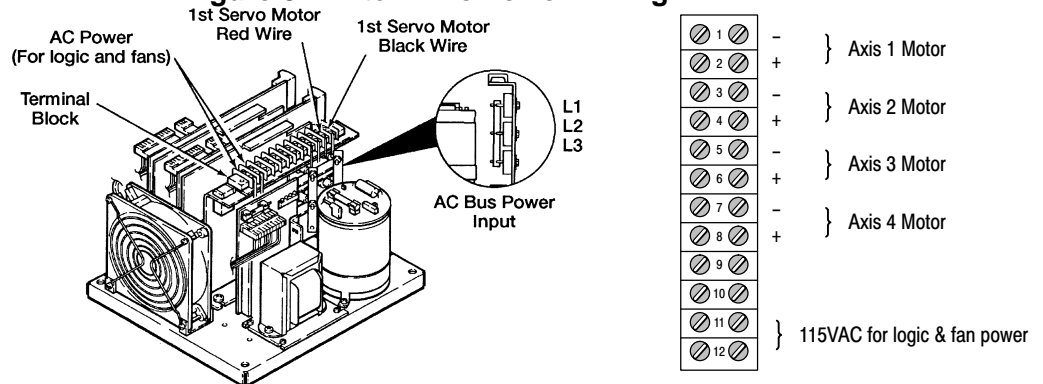

**6 Axis Procedure** (Refer to Figure 3-5).

1. Be sure all voltage sources are turned off.
2. Connect AC power from the isolation transformer to AC Bus Power Input L1, L2, L3. Single phase use L1, L2.
3. Connect 115VAC power to logic and fan input terminals of the 2 position terminal block to the right of the 12 position terminal block.

**For UMX-XXX-5 or UMX-XXX-6, use 240 VAC 50 Hz nominal to supply logic and fan power.**

4. Connect the negative and positive wires from each servo motor to the terminal block as shown in the figure.

**Figure 3-5 6 Axis Power Wiring**

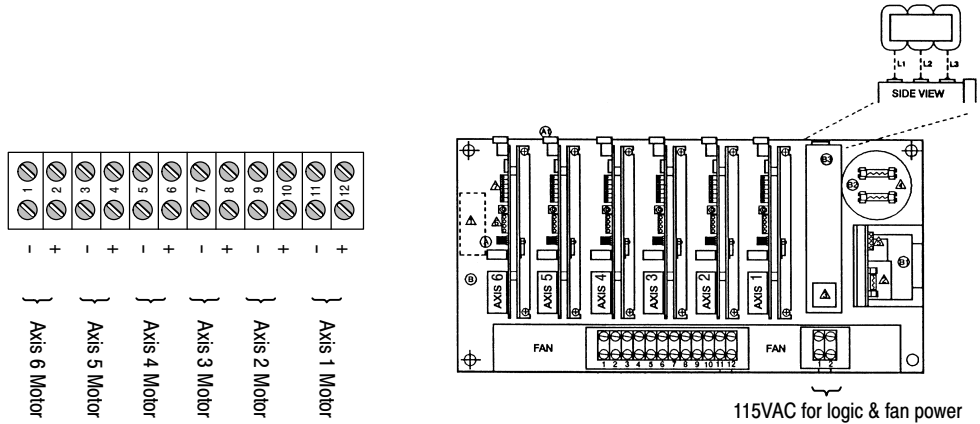

**Signal Wiring**

**Input Signals** (Refer to Figure 3-6).

1. Connect the positive (+) tachometer wire (of the first servo motor) to the Tach (+) input (pin 5) of the Phoenix Connector for Axis 1.
2. Connect the negative (-) side tachometer wire (of the first servo motor) to the Tach (-) input (pin 6) of the Phoenix Connector for Axis 1.
3. Connect the tachometer cable shield to (pin 11) common.
4. Connect the - lead of a VOM to (Test Point) TP-1 and the + lead to TP-6. Rotate the tachometer by hand and observe the VOM. Clockwise rotation (facing the shaft) should cause a positive voltage measurement.

**Figure 3-6 Input Signal Connector**

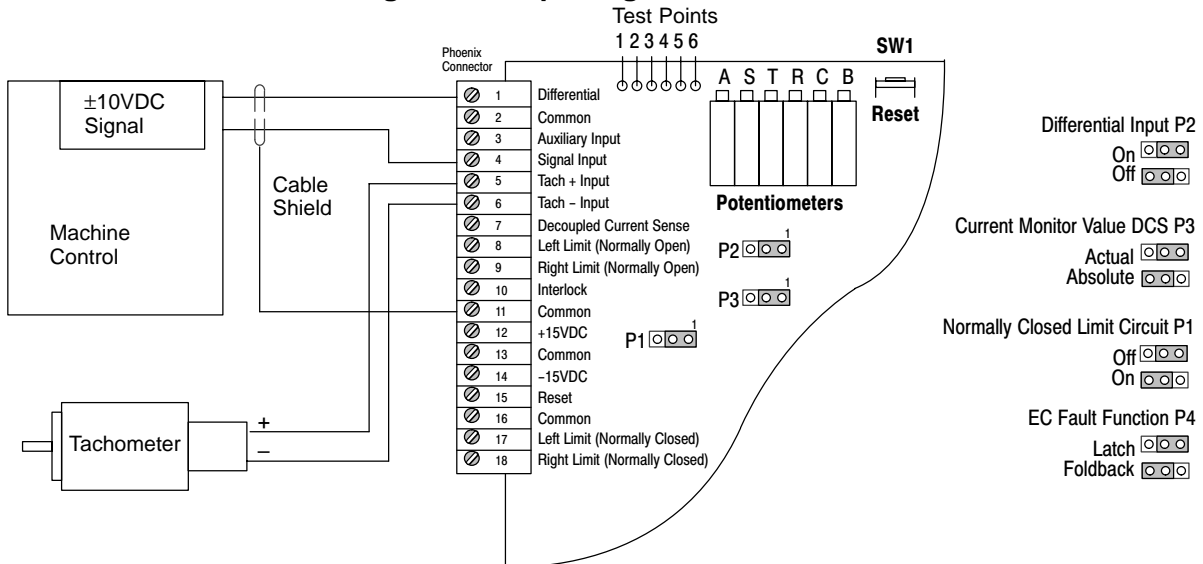

5. Repeat steps 1, 2, 3 and 4 for each of the tachometers and be sure to use the Phoenix Connector for the correct Axis.
6. Differential Command Input – Connect the input Velocity Command Signal to pin 1 and its return to pin 4. Ensure that jumper P2 is in its right most position (pins 1 and 2).  
Single Ended Command Input – Connect the Velocity Command Signal to pin 4 and its return to pin 2. Ensure that jumper P2 is in its left most position (pins 2 and 3).
7. Repeat for each axis and be sure to use the Phoenix Connector for the correct Axis.

### Limit, Interlock and Reset Switches (Refer to Figure 3-7).

When the left or right limit is activated, motor rotation in that direction is not allowed. An activated limit switch disables the amplifier and the motor will coast to a stop. This function can be used for an axis over-travel limit to prevent further operation in the inhibited direction, but it does allow the control to back out of the limit (rotate in the opposite direction).

1. Connect a normally open switch to pins 8 & 9. Or, if you use normally closed switches, connect these to pins 17 & 18.
2. Set jumper P1 for normally open or closed operation.

Note: If PI is in the left position (normally closed) and no limit switches are connected, the control will assume the limit switch has opened and disable its output in that direction (i.e. the control will not operate).

3. Connect the switch common to pin 16.
- Steps 4 and 5 are optional input connections.
4. Connect the interlock switch to pin 10.
5. Connect the reset switch to pin 15.
6. Repeat steps 1, 2, 3, 4 and 5 for each axis.

**Figure 3-7 Limit, Reset and Interlock Connections**

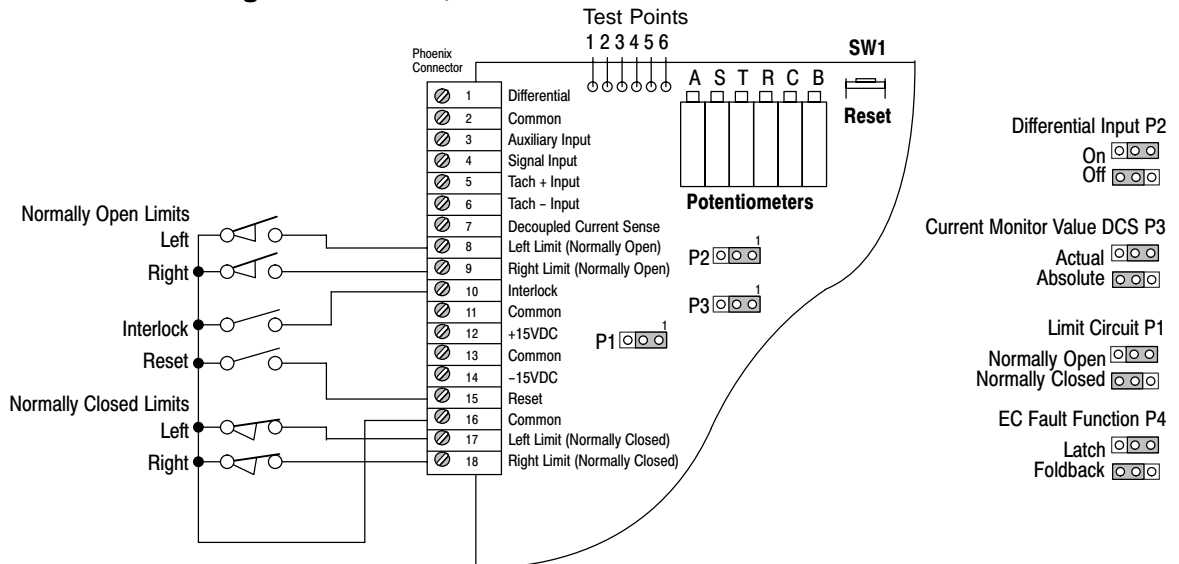



---

## Optional Input Connections

### **Current Monitor Interface** (Connections are made at pins 7 and 11).

Decoupled current sense (DCS) is an analog representation of amplifier current. Using an oscilloscope, a technician can look at output current of the amplifier. An analog output voltage of 1 volt peak to peak represents approximately 1/10 of peak current. If you have a UM3015HS-100 amplifier card and your DCS voltage is 1.5V peak, amplifier output current is:

- 30 amps peak  $1/10 \times (1.5) = 4.5$  amps OR
- 3 x DCS voltage = output current (for UM3015)
- 1.5 x DCS voltage = output current (for UM1506)

### **Interlock** (Connection is made at pin 10, see Figure 3-8).

The interlock is bidirectional. That is, it can be closed to common internally or externally to disable the control. The internal interlock activates for:

- High bus or low bias voltage. (VE Indicator ON).
- Ground Fault current. (GF Indicator ON).
- Excess I<sup>2</sup>T current or overtemp (in latch mode). (EC indicator ON).
- Excessive bus surge current. (SC Indicator ON).

Refer to Section 5 Troubleshooting for corrective action.

The interlock function can be used to tie multiple servo control cards together, locking all the cards together. In this configuration, a fault on one axis card will interrupt all the other cards, the output stages of all the servo control cards will be disabled (i.e., motors will coast to a stop with no holding torque). An emergency stop could also be wired to the interlock line.

### **Reset** (Connection is made at pin 15, see Figure 3-9).

The reset line is used to externally reset the servo control. When the reset signal is closed to common temporarily and then released, the control will be enabled (restarted) if a fault condition is not present. If activated, the reset line will totally disable the servo control card until it released. The Reset button, SW1, a momentary switch was added for your convenience and will provide the same results (see Figures 3-6 and 3-7).

### **±15VDC** (Connection is made at pin 12 and 13, see Figure 3-7).

This is ±15VDC at 50mA power source. This output can be used by external devices or can be used with a voltage divider network to provide the signal input to the servo control card.

## Emergency Stop

Some applications require a positive stop to disconnect the motor in the event of an emergency. A relay with 4 sets of contacts can be connected as shown in Figure 3-10 to provide the E stop function.

**Figure 3-10 Emergency Stop Connection**

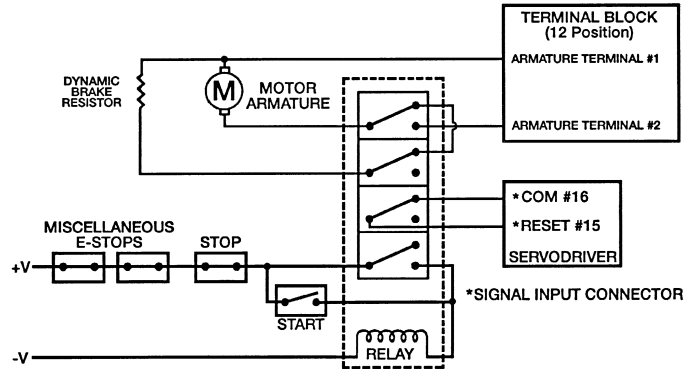



# Section 4 Adjustments and Start-Up

## Overview

The start-up information provided in this section contains the procedures necessary to get each axis running and properly tuned using the 6 adjustment potentiometers on each servo control board. Each axis should be started independently to minimize problems.

The following procedure is for operating the UM series servo control in a velocity loop with a tachometer. To operate in current (torque) mode, refer Start-Up Torque Mode.

## Initial Settings

Before power is applied, the potentiometers on each servo control board should be set as shown in Table 4-1. (See Figure 4-1 for locations).

**Table 4-1 Initial Potentiometer Settings**

Potentiometer	Position	Condition
A (Auxiliary)	Fully counterclockwise	Off
S (Signal)	Fully counterclockwise	Off
T (Tachometer)	Fully clockwise	Low
R (Response)	Fully counterclockwise	Low
C (Current Limit)	One turn clockwise	Low
B (Balance)	Leave as shipped	Center

Note: All pots have a 15 turn range and are without a hard stop. You may hear a 'click' when the end is reached.

**Figure 4-1 Jumper P6 Location**

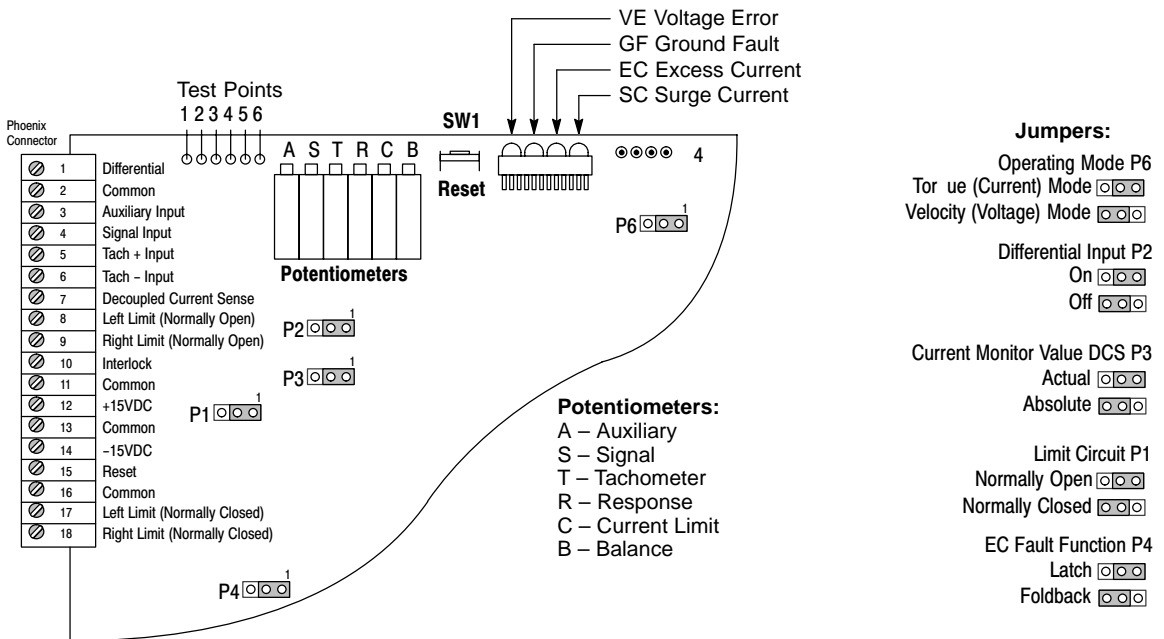

---

## **Start-Up Velocity Mode** (Power On)

1. Decouple all loads from the motors.
2. Disconnect all axes except the first (axis 1)
3. Switch on the Logic and Fan AC power input.
4. Observe that the fan starts and three of the green LED's on the logic power supply (+ 15V, - 15V and AC) are ON.
5. Apply the AC input power to the external isolation transformer and verify that the fourth green LED labeled "BUS" is ON.
6. Observe that the servo motor does not rotate. If the servo motor runs up to a high speed at an uncontrolled rate, reverse the tachometer or armature leads.
7. Apply a signal step input command between 0 and 10VDC at terminals 1 and 4 on the signal input connector. A 5VDC input voltage is recommended.
8. Slowly rotate the (S) Signal pot 4 turns clockwise, observing that the motor shaft rotates at a reasonably controlled rate. Be careful with this step because if a tachometer is miswired, the motor can runaway.
9. Slowly rotate the (C) Current pot 4 turns clockwise, observing that the motor shaft speed may increase and stabilize.
10. If the motor shaft rotates in the wrong direction for a given polarity input voltage, reverse both the tachometer wires and the red and black armature wires at the terminal block.
11. Verify that the Left and Right limit switches properly inhibit the axis travel in the direction defined.
12. Slowly rotate the (S) pot clockwise to increase the motor shaft speed to full speed.
13. If a high output voltage tachometer is used, it may be necessary to turn the (T) pot a few turns counterclockwise to achieve the desired speed.
14. Slowly rotate the (C) pot to the fully clockwise position if the servo control's peak current is less than the rated peak current of the motor. If the peak motor current is less than that of the servo control, a reduced current must be maintained.
15. Slowly turn the (R) pot clockwise until the axis becomes unstable and then turn the pot back one turn counterclockwise. This adjustment is best done with a step input command (refer Figure 4-2 for typical responses).
16. If the motor shaft rotates with the signal input voltage at zero, slowly adjust the (B) pot to eliminate any motor shaft rotation.
17. If the motor shaft overshoots when stopping, slowly adjust the (T) pot counterclockwise, be careful not to turn it to fully counterclockwise. Fully counterclockwise adjustment of the (T) pot may cause the speed of the motor shaft to become uncontrollable.
18. The (S) pot can now be adjusted to optimize the maximum response for the given signal input voltage range.
19. Turn off AC input power to the external isolation transformer and AC input power to the Logic & Fan input.

20. Connect the motor for the next axis.
21. Repeat steps 3 through 20 for each axis.
22. Turn off AC input power to the external isolation transformer and AC input power to the Logic & Fan input.
23. Connect the loads to each motor and turn power ON.
24. Repeat steps 15 through 18 for each axis with the loads connected to the motor shafts. This is the final fine tuning.

**Figure 4-2 Typical Response**

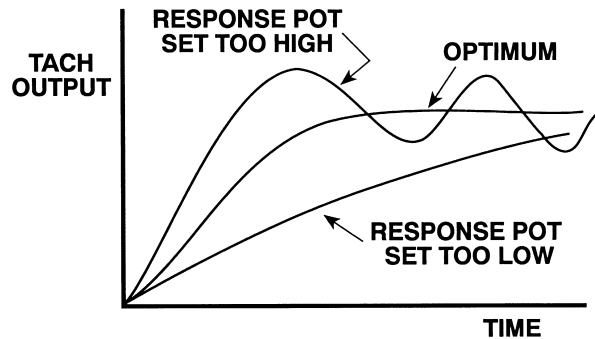

### Test Points

There are six test points to help with set up. After a card is tuned, the potentiometer's resistance can be measured and recorded for future reference. Other cards can be preset to these values to minimize the adjustment procedure.

<u>Test Point</u>	<u>Description</u>
TP1	Common
TP2	"A" Pot Wiper Resistance
TP3	"S" Pot Wiper Resistance
TP4	"T" Pot Wiper Resistance
TP5	"R" Pot Wiper Resistance
TP6	Tach monitor (measures actual tach voltage)

### Start-Up Torque Mode (Power On)

1. Select current mode operation by placing jumper P6 in its right most position (pins 1 & 2). Refer to Figure 4-1.
2. Set the T pot fully counterclockwise.
3. Set the S pot fully clockwise.

Note: If the pot A is used, set it fully clockwise and pot S counterclockwise.

4. Switch on the Logic and Fan AC power input.



# Section 5

## Troubleshooting

---

### **Overview**

This troubleshooting guide describes the symptoms and provides information to check the causes of a fault and restore operation. Most of the faults can be identified by observing the four LED fault indicators on each servo control card and using a VOM.

Unless the cause of a malfunction is obvious and readily correctable, replace the servo control card with a new one. This will get the system running most quickly and reduce the equipment's down time. Under no circumstances should you modify or replace any card components. This could compound the problem and will void the equipment warranty.

In addition, if a problem develops in a system that was previously operating well, do not make any adjustments without first diagnosing the cause or causes. To arbitrarily readjust the unit will only compound the problem.

### **Maintenance**

The servo control requires little maintenance. Adjustments are readily accessible near the top edge of the circuit board. LED indicators provide immediate indication of servo control status and fault indication.

Check the control and ensure that it is clean to allow proper cooling. If cleaning is required, disconnect power and wait for the bus voltage to bleed down to zero volts (approximately 5 minutes). Then, carefully vacuum away any loose dirt or use clean compressed air can to blow away dust and dirt.

### **Initial Checks**

Begin your troubleshooting with a systematic and complete check of power lines and input signals to the servo control.

1. Check the input speed command signals. Determine that the signals reach the servo control input connector.
2. Check the external limit switches, if used, to determine that they are functioning properly.
3. Check the logic power and the DC bus voltages to determine that both have the correct voltages present (refer to Section 6 for specifications).
4. Check for open fuses and circuit breakers.
5. Check for correct jumper positions.
6. Check for damaged control or equipment wiring.
7. Check for abnormally hot components.
8. Check for loose or broken terminals.
9. Check for burned insulation or components.

### **Reset the Servo Control**

To reset a servo control with a fault, the following procedure must be performed.

1. Check the servo control and wiring for obvious problems.
2. Review Table 5-1 for a possible explanation of the cause and corrective action to be taken.
3. Reset the axis or all axes by one of three means; remove and reapply logic power to the chassis, temporarily close the reset line on the signal input connector to common, or press the reset button on each card.



**Table 5-1 Troubleshooting**

<b>Symptom</b>	<b>Corrective Action</b>
No torque in one direction.	Check left or right limit switch wires to insure that they are not tied to common. Verify that the proper limit switches are used. Verify jumper P1 position.
No output in either direction.	Check interlock and reset wires to insure that they are not tied to common. Perform setup procedure and verify all connections. Observe whether all 4 green LEDs are lit on logic supply. If all 4 LEDs are not lit, perform start-up procedures in Section III and recheck all steps. Verify jumper P1 is not missing. If only (bus) LED is lit, check AC logic fuse on top of unit to verify it is good and in the holder. (Remove incoming AC power before changing any fuse. To change the fuse, press the fuse holder cover to the side and lift up. You will find a spare fuse underneath the main fuse. Install the new fuse and press the cover down securely, noting that it snaps back in place. Reapply incoming AC power.)
Motor runs at uncontrolled speeds.	Verify that servo control is not set for current mode. Verify P6 position. Verify that (T) pot is not set full CCW. Reverse tach leads and verify that tach voltage is present at signal input connector when motor is running.
Oscillation in motor seen as instability or rocking of motor shaft. Motor may have a growling sound.	Refer to Start-Up and Adjustment Procedures for proper setting of (R) and (T) pots.
Motor exhibits a "dead zone" when responding to a signal input.	Verify that the bus voltage is sufficient for the motor. Verify that inductance is not too high (see Section 6). Refer to Section 4 for proper setting of (R) pot.

**Table 5-1 Troubleshooting** Continued

<b>Symptom</b>	<b>Corrective Action</b>
<p>VE Low output voltage from logic power supply.</p> <p>Bus Voltage too high.</p>	<p>Check incoming power to logic power supply and verify that it is in specified range. If in range, disconnect any external load on logic power and reset servo control.</p> <p>Check fuse on overvoltage protector. If open, replace before resetting servo control.</p> <p>Recheck voltage and if problem still exists, disconnect power to each servo control individually and isolate which servo control is drawing excess current.</p> <p>Check to insure (T) pot is turned too far CCW.</p> <p>Reset servo control and cycle axis. Watch, for VE indicator to light during deceleration of axis. If VE indicator lights, increase the deceleration time reset, and cycle equipment until problem is resolved.</p>
<p>EC RMS current output is exceeded.</p> <p>Over-temperatures</p>	<p>Check axis for instability (oscillations. Correct by turning (R) pot CCW.</p> <p>If not instability, look for high tach noise (over 5% p-p) by using an oscilloscope. If present, check tach shielding.</p> <p>If overloading is suspected, a larger servo control may be required. Contact your supplier for alternatives.</p> <p>Verify that adequate air circulation is present. Check for overload using oscilloscope on the DCS line to determine current to motor. 1 volt is approximately 1/10 of the peak rated output current. If not overloaded, unit should be returned for repair.</p>
<p>GF Current flow is detected at ground potential.</p>	<p>Check fuse on logic power supply. If open, replace before reset. This problem can be caused by a short across logic power. Reset servo control card. If problem still exists, the control may require service since parts may be damaged.</p> <p>This problem can also be caused by a short to ground. Remove armature connections and check for short to ground. If none exists, remove servo control card and reset unit. If problem is resolved, the servo control card should be returned for repair.</p>
<p>SC Rated peak current has been exceeded.</p>	<p>Verify that motor has sufficient inductance. Refer to Specifications in Section 6. Reset servo control card and see if problem immediately reappears. If so, check for short in motor. If motor is not shorted, unit has an internal short and should be returned for repair.</p> <p>If upon resetting the servo control card, the unit does not fault, cycle equipment while watching for a fault during acceleration. If fault occurs, increase the acceleration time, reset and cycle until problem is eliminated.</p>



# Section 6 Specifications & Product Data

---

## Identification

### Complete Servo Control

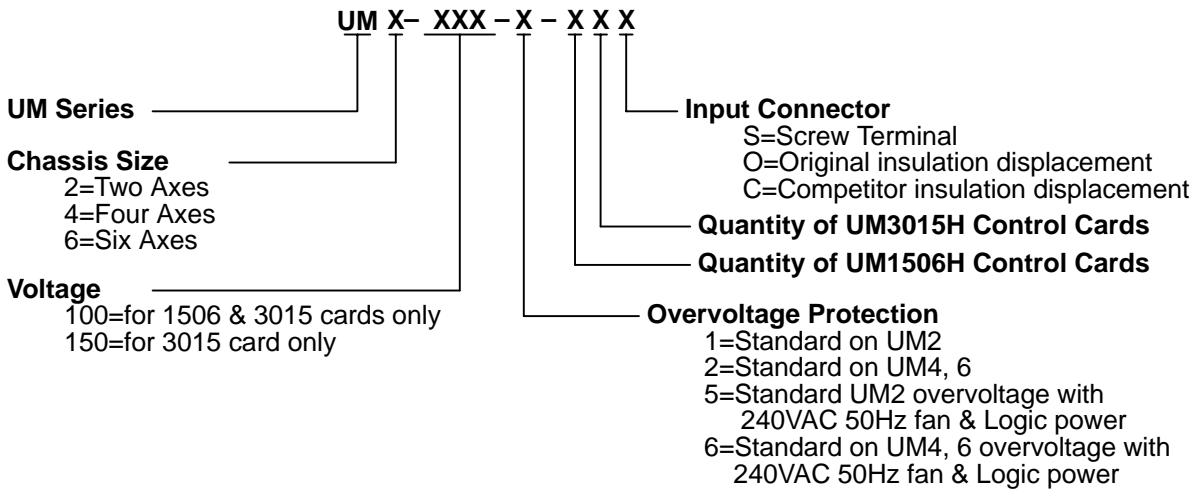

### Chassis (Including Power Supply)

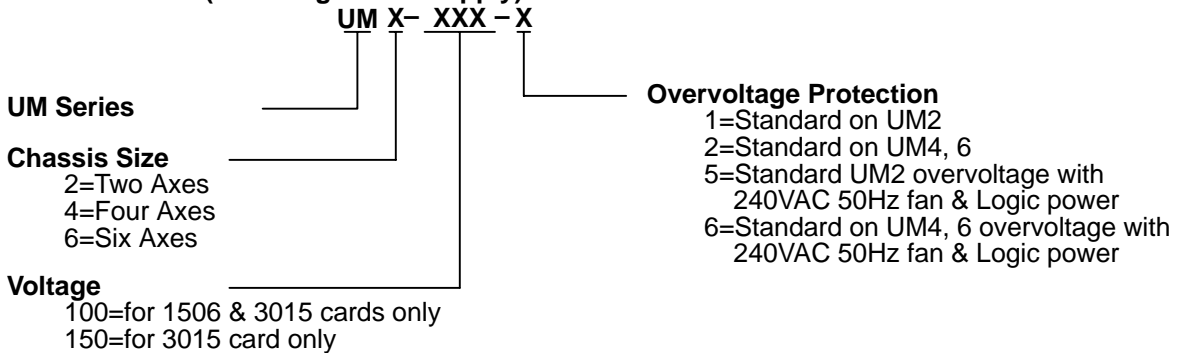

### Control Card only

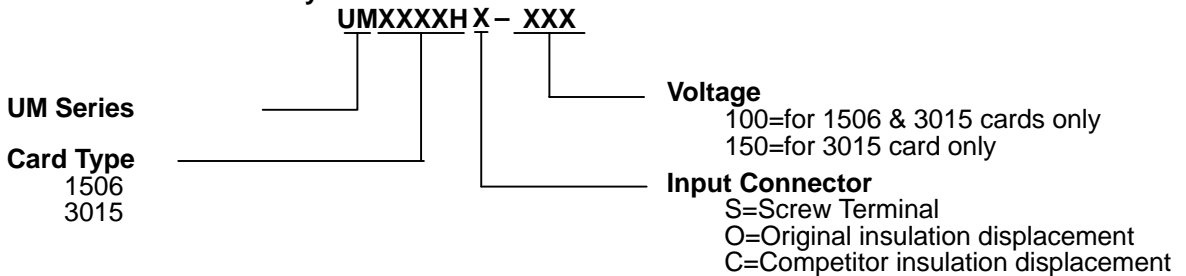

### Chassis/Power Supply Assemblies

Description	Unit	UM2		UM4		UM6	
		-100	-150	-100	-150	-100	-150
Rated Bus Input Nominal	VAC	70	105	70	105	70	105
Rated Bus Input Range	VAC	20-77	20-115	20-77	20-115	20-77	20-115
Number of Phases		1	1	1 or 3	1 or 3	1 or 3	1 or 3
Logic & Fan Power	VAC	105-125	105-125	105-125	105-125	105-125	105-125
Nominal Output Voltage	VDC	100	150	100	150	100	150
Voltage Output Range	VDC	28-109	28-162	28-109	28-162	28-109	28-162
Max. Cont. Current	A	27	27	27/50	27/50	27/50	27/50
Maximum Power	kW	1.89	2.86	1.89/4.3	2.86/6.45	1.89/4.3	2.86/6.45
Rated Bus Volt.	VDC	100	150	100	150	100	150
+15 VDC (Internal)	A	1	1	1	1	2	2
-15 VDC (Internal)	A	1	1	1	1	2	2
Operating Temp.	°C	0-50	0-50	0-50	0-50	0-50	0-50
Weight	lbs.	14	14	20.6	20.6	25	25
Continuous Rating	watts	250	250	500	500	500	500
Peak Rating (W)	watts	2200	4000	4400	8000	4100	8000
Clamp Rating	VDC	118	185	118	185	118	185
Shut Down Point typical	VDC	130	200	130	200	130	200

### Servo Control Card

Description	Unit	6 amp control	15 amp control	15 amp control
Rated Bus output voltage	VDC	100	100	150
Cont. Current	A	6	15	15
Peak Current (max time 1.5 sec)	A	15	30	30
Max. time	sec.	1.5	1.5	1.5
Switching Freq.	kHz	20	20	20
Form Factor		1.01	1.01	1.01
Min. Inductance	MHz	1.0	1.0	2.0
Freq. Response	kHz	2.5	2.5	2.5
Drift	μV/°C	10	10	10
Overall Gain	A/V	0-6000	0-6000	0-6000
Input Impedance	kΩ	20	20	20
Bus nominal	VDC	100	100	150
Bus range	VDC	28-109	28-109	28-162
-15 VDC	mA	50	50	50
+15 VDC	mA	250	250	250
Operating Temp.	°C	0-50	0-50	0-50
Humidity (non-condensing)	%	5-95	5-95	5-95
Weight	lbs.	1.4	1.4	1.4

## UM2, UM4 Installation Instruction Drawing

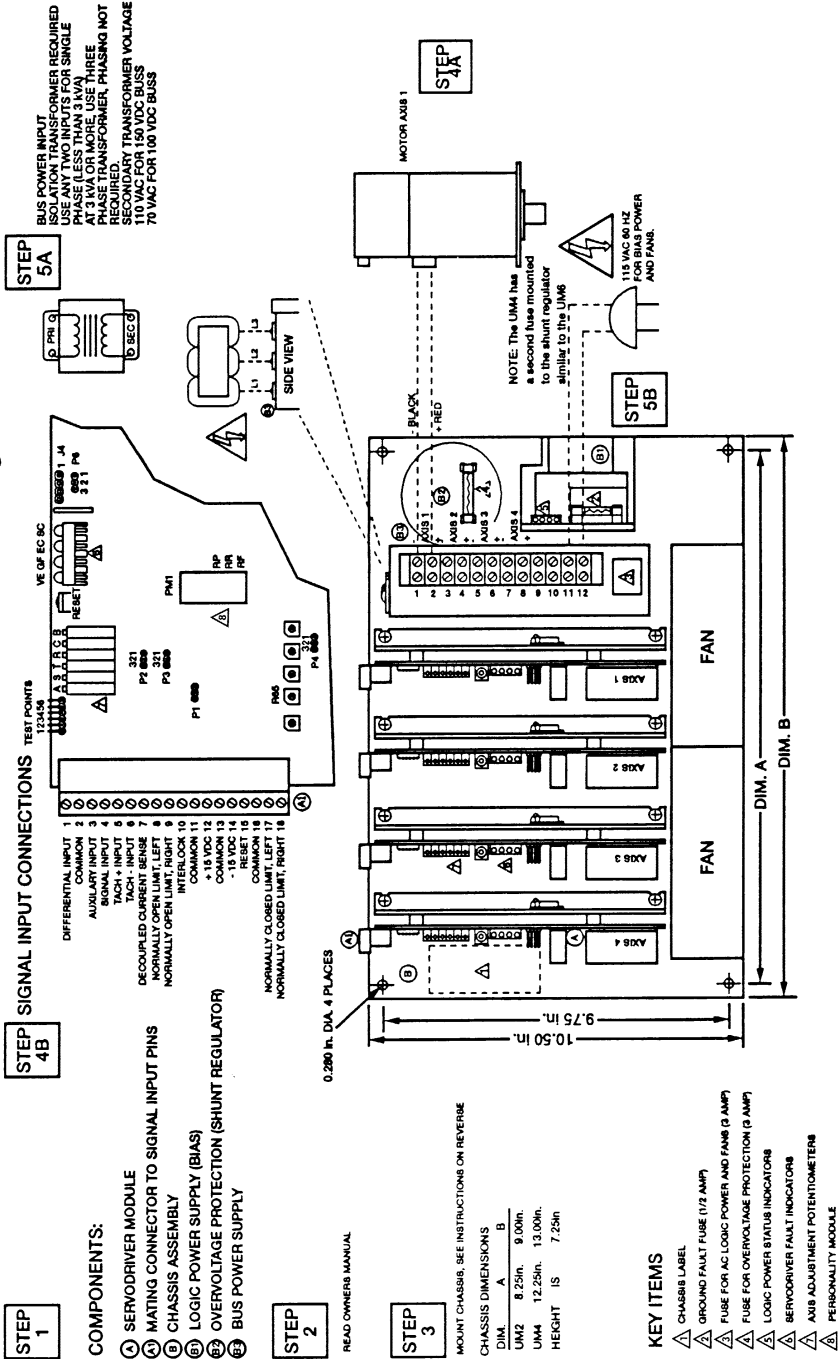

# UM6 Installation Instruction Drawing

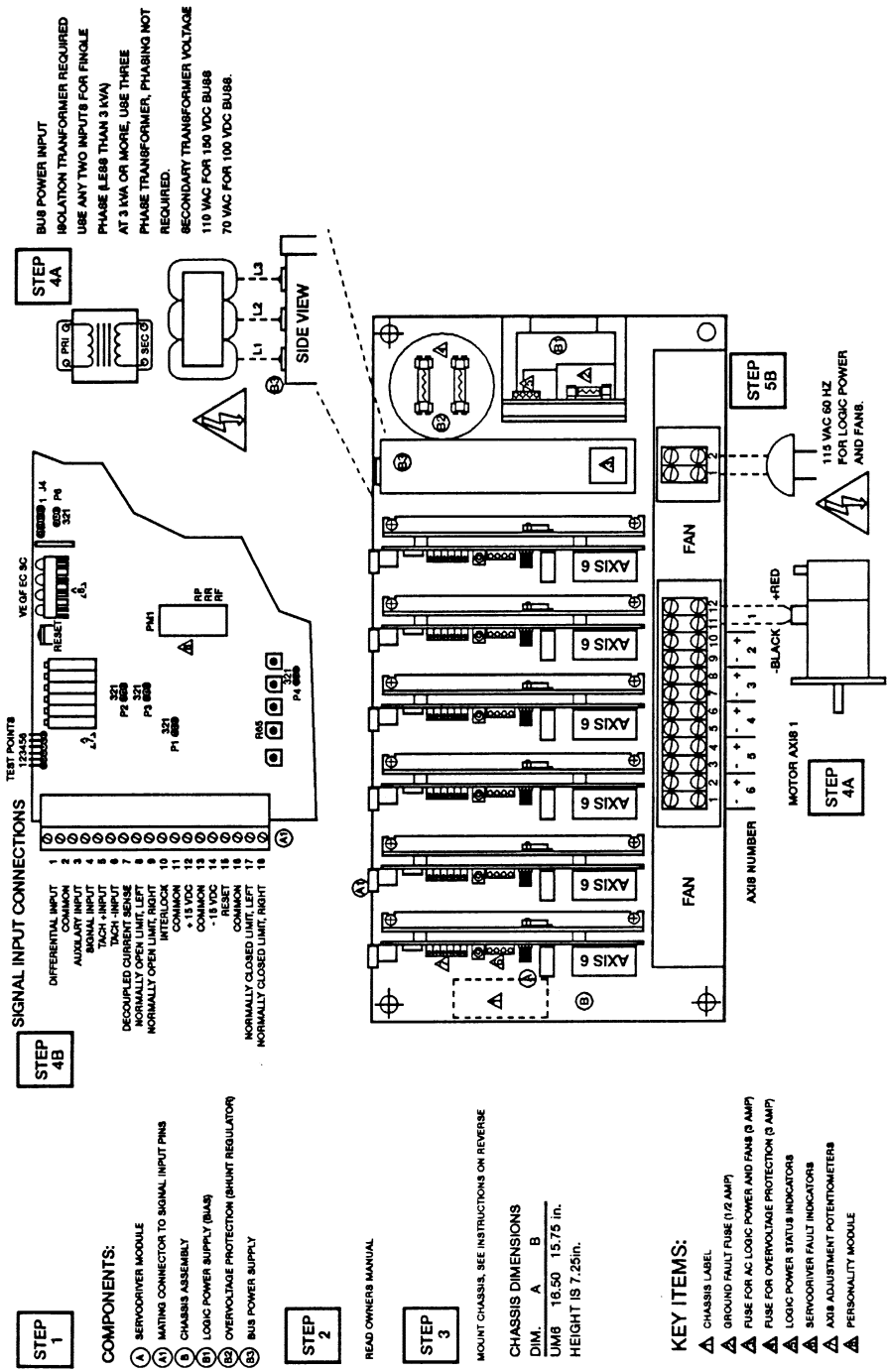

**STEP 1**

**COMPONENTS:**

- ① SERVO/DRIVER MODULE
- ② MATING CONNECTOR TO SIGNAL INPUT PINS
- ③ CHASSIS ASSEMBLY
- ④ LOGIC POWER SUPPLY (BUS)
- ⑤ OVERVOLTAGE PROTECTION (BURNT REGULATOR)
- ⑥ BUS POWER SUPPLY

**STEP 2**

READ OWNERS MANUAL

**STEP 3**

MOUNT CHASSIS, SEE INSTRUCTIONS ON REVERSE

**CHASSIS DIMENSIONS**

DIM.	A	B
UM6	18.50	15.75 in.
	HEIGHT IS 7.25in.	

**KEY ITEMS:**

- ▲ CHASSIS LABEL
- ▲ GROUND FAULT FUSE (1/2 AMP)
- ▲ FUSE FOR AC LOGIC POWER AND FANS (3 AMP)
- ▲ FUSE FOR OVERVOLTAGE PROTECTION (3 AMP)
- ▲ LOGIC POWER STATUS INDICATORS
- ▲ SERVO/DRIVER FAULT INDICATORS
- ▲ AXIS ADJUSTMENT POTENTIOMETERS
- ▲ PERSONALITY MODULE

Dimensions – Inches (mm)

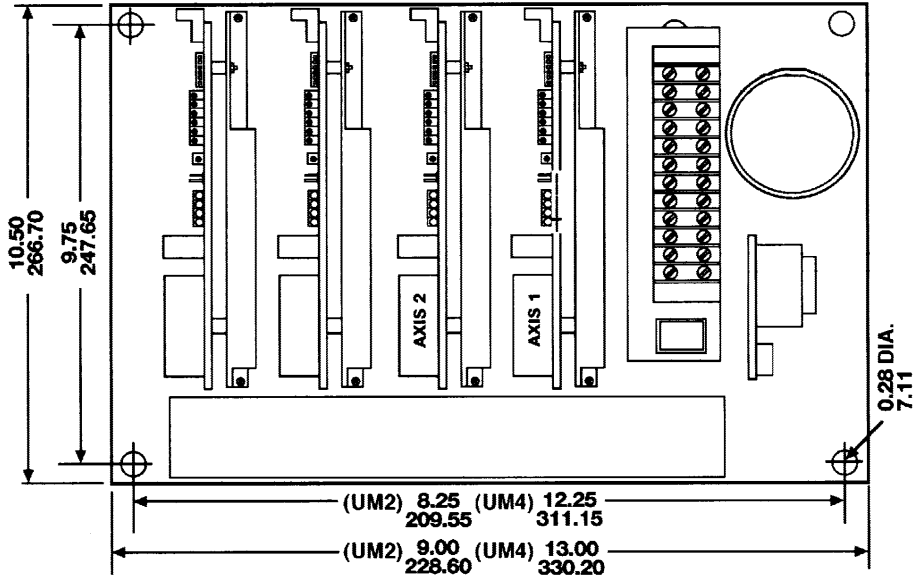

UM4 shown.  
Height = 7.25 (184.15)





# Appendix A

## Personality Module

### Jumper and Personality Module Settings

**Personality Module Current Settings** Refer to Figure A-1.

The personality module allows you to calibrate the servo control. Resistors can be soldered to the module to select the upper limit values of the following:

- Peak Current
- Continuous Current
- Foldback Current

**Figure A-1 Personality Module**

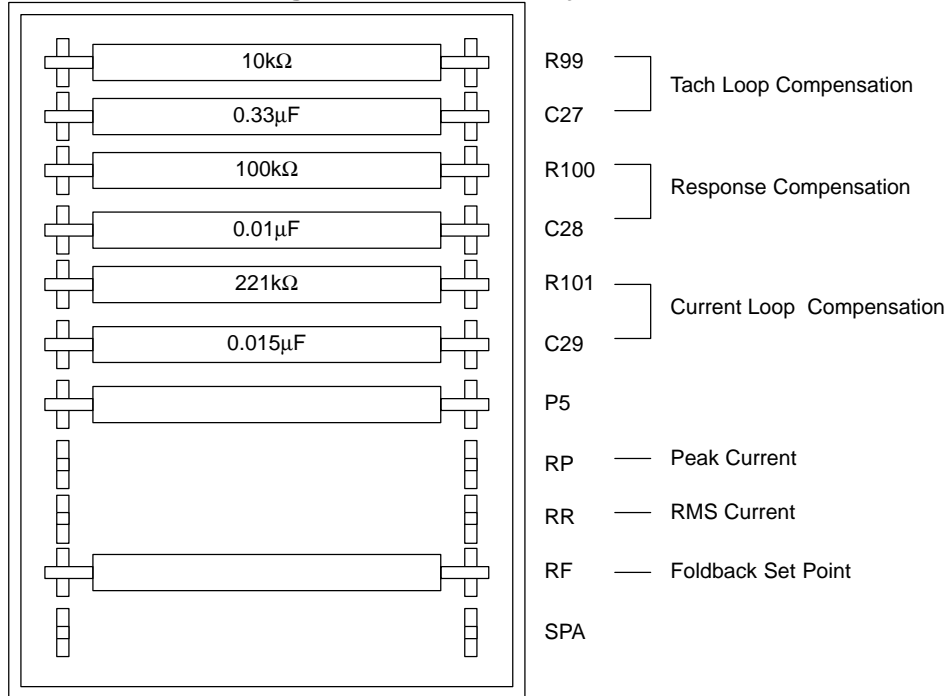

## Peak and Continuous Current Levels

Adding a resistor reduces the set values from the specifications in Section 6.

### Peak / Continuous Current Levels

Peak		Continuous	
I <sub>peak</sub> (Amps)	RP (Ohms)	I <sub>RMS</sub> (Amps)	RR (Ohms)
<b>UM1506HS-100</b>			
15	OPEN	7	OPEN
14	42.2k	6	68.4k
13	17.4k	5	26.7k
12	10.2k	4	12.1k
11	6.81k	3	6.19k
10	4.99k	2	3.01k
9	3.65k	1	1.00k
<b>UM3015HS-100/150</b>			
30	OPEN	15	OPEN
28	14.0k	14	475k
26	8.87k	13	97.6k
24	6.19k	12	59.0k
22	4.64k	11	31.6k
20	3.57k	10	23.2k
18	2.74k	9	16.2k
16	2.15k	8	11.3k
14	1.8k	5	4.32k

### Foldback Levels

UM1506		UM3015	
Foldback Current (Amperes)	Foldback Resistance (RF Ohms)	Foldback Current (Amperes)	Foldback Resistance (RF Ohms)
2	453	5	453
2.5	715	7	715
3	1.0k	9	1.0k
4	1.37k	11	1.37k
5	1.82k	13	1.82k
6	2.43k	15	2.43k

## Record of “Set Up” Configuration

It is highly recommended that a record be kept of the set up details for future reference. This will come in quite handy for new units, field replacements, and diagnostic aid.

Using recorded values from similar set-ups will reduce installation time, and service can be conducted faster. These charts provide a common diagnostic communication tool for the builder or system integrator.

Jumper	Jumper Function	Jumper Identification
P1	Normally closed limit circuit	ON $\begin{matrix} 3 & 2 & 1 \\ \text{---} & \text{---} & \text{---} \\ \text{---} & \text{---} & \text{---} \end{matrix}$ OFF
P2	Differential Input	OFF $\begin{matrix} 3 & 2 & 1 \\ \text{---} & \text{---} & \text{---} \\ \text{---} & \text{---} & \text{---} \end{matrix}$ ON
P3	Current monitor value DCS	Absolute $\begin{matrix} 3 & 2 & 1 \\ \text{---} & \text{---} & \text{---} \\ \text{---} & \text{---} & \text{---} \end{matrix}$ Actual
P4	EC Fault Function	Foldback $\begin{matrix} 3 & 2 & 1 \\ \text{---} & \text{---} & \text{---} \\ \text{---} & \text{---} & \text{---} \end{matrix}$ Latch
P6	Amplifier Mode	Velocity $\begin{matrix} 3 & 2 & 1 \\ \text{---} & \text{---} & \text{---} \\ \text{---} & \text{---} & \text{---} \end{matrix}$ Current

Potentiometer Settings			Axis			
	POT	TP	#1	#2	#3	#4
Auxiliary Input	A	2				
Signal Input	S	3				
Tach Gain	T	4				
Response	R	5				

Measure ohm readings for the four compensation potentiometers and record them in the chart above. Take your resistance measurements between common (TP1) and the appropriate pot test point.

Note: Power down the servo control and disconnect the signal input connector before making any measurements.



# **BALDOR<sup>®</sup>** **MOTORS AND DRIVES**

**BALDOR ELECTRIC COMPANY**  
**P.O. Box 2400**  
**Ft. Smith, AR 72902-2400**  
**(501) 646-4711**  
**Fax (501) 648-5792**  
**[www.baldor.com](http://www.baldor.com)**

<b>CH</b> TEL: +41 52 647 4700 FAX: +41 52 659 2394	<b>D</b> TEL: +49 89 90 50 80 FAX: +49 89 90 50 8491	<b>UK</b> TEL: +44 1342 31 5977 FAX: +44 1342 32 8930	<b>F</b> TEL: +33 145 10 7902 FAX: +33 145 09 0864
<b>I</b> TEL: +39 11 562 4440 FAX: +39 11 562 5660	<b>AU</b> TEL: +61 29674 5455 FAX: +61 29674 2495	<b>CC</b> TEL: +65 744 2572 FAX: +65 747 1708	<b>MX</b> TEL: +52 47 61 2030 FAX: +52 47 61 2010

МН1213

***UM Series DC Servo Control***

**MN1213**