

MATERIALS & PARTS LIST				
NO.	QTY	DESCRIPTION	MATL	REMARKS
1	1	1.5 X 3 X 7.2	CR 1018	FACE ALL SIDES
2	1	CL-4-SCA CAM CLAMP	-	IN STOCK @ T.R. GOLDSMITH 877-452-6462
3	1	.5" FREE LENGTH SPRING Ø .062 WIRE	-	USE STANDARD FIXTURE SPRING

- GENERAL NOTES:
1. TO SCALE, ALL DIMENSIONS NOT SHOWN
 2. FOR INFORMATION NOT SHOWN WORK TO TOOLMAKERS STANDARD PRACTICE
 3. LOCATE ALL SCREWS AND DOWELS TO SUIT

- USAGE:
1. RAZE CLAMP HANDLE TO VERTICAL
 2. SLIDE STRAP BACK TO STOP
 3. LOWER BUTT PLATE BLANK OVER PIN
 4. SLIDE STRAP FORWARD TO STOP
 5. LOWER CAM TO HORIZONTAL

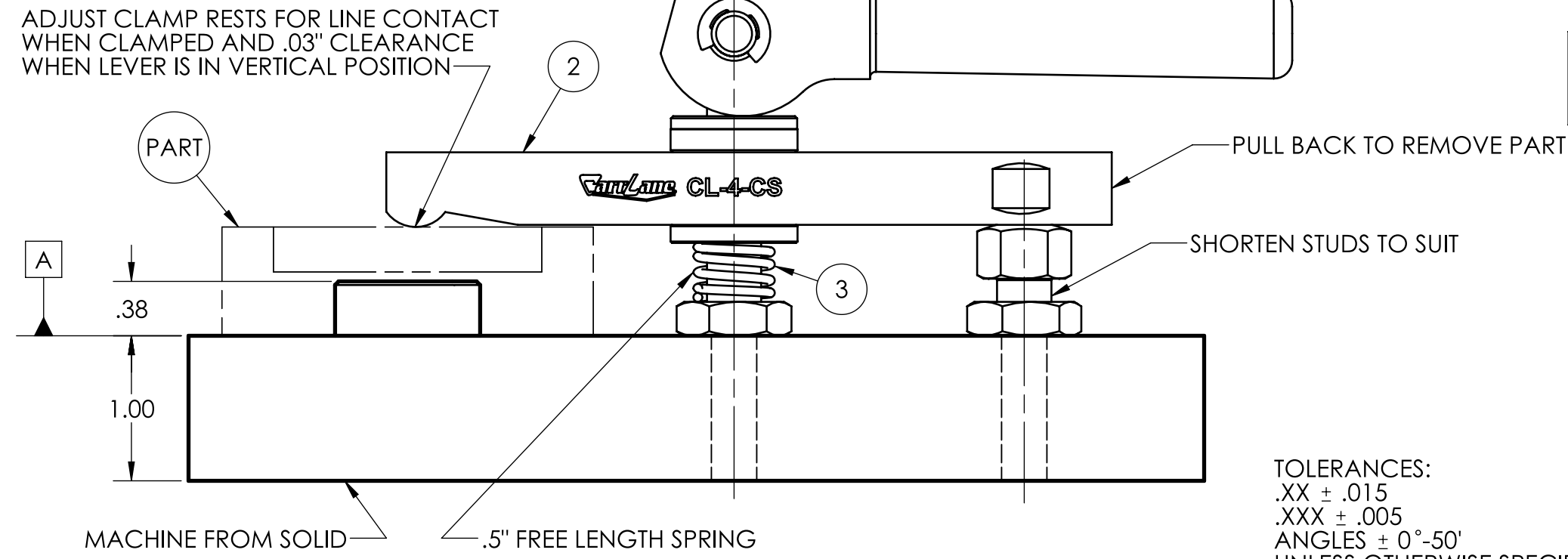
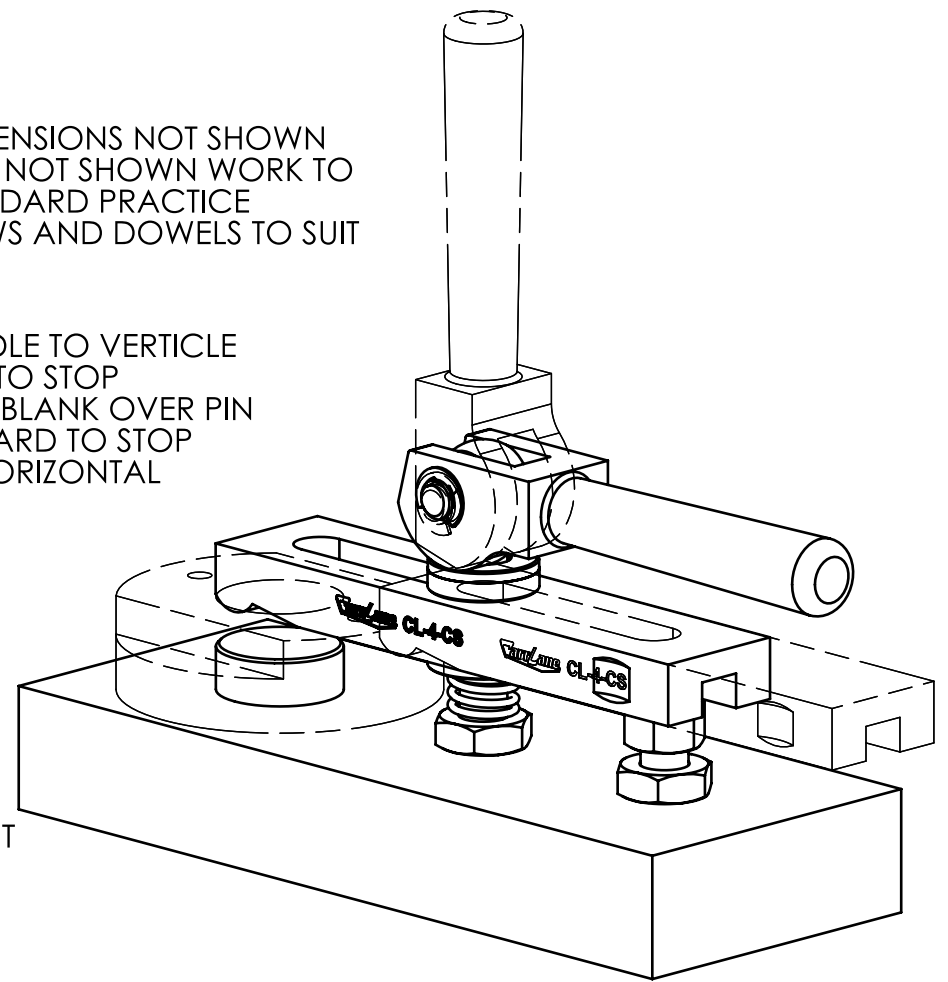

TOLERANCES:
 .XX ± .015
 .XXX ± .005
 ANGLES ± 0°-50'
 UNLESS OTHERWISE SPECIFIED

SPSU SOUTHERN POLYTECHNIC STATE UNIVERSITY

VICE HELD BUTT PLATE FIXTURE

DR. BY: KURT JACOBSON	MET3331	SHEET NO.
DATE: 10/10/2016	SCALE: 1:1	1 OF 1