

# HITACHI WJ200 Inverter Wiring

## Source Type Logic

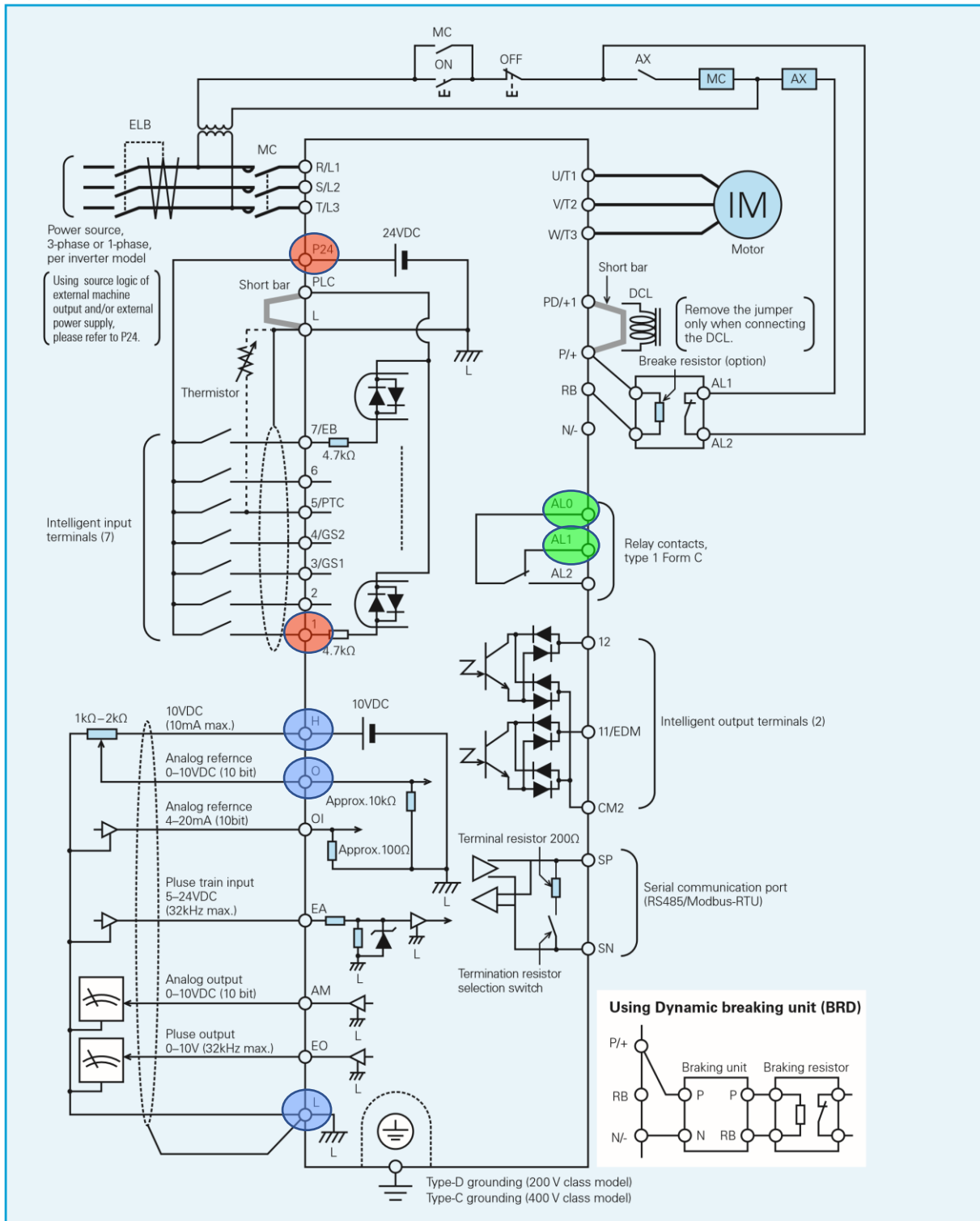

### Spindle enable:

**P24** – TB4.6 Enable 24V+ | Input 1 – TB4.5 Enable -

### Spindle speed Target value 0-10V:

**H** 10V + – TB4.3 | **O** Target 0-10V – TB4.2 | **L** GND – TB4.1

### E-Stop Alarm Relay NC:

**AL0** 24V+ | **AL1** hm2\_7i76e.0.7i76.0.0.input-10-not



HITACHI WJ200 Inverter Wiring

