

* For 5V , please connects with wires directly.
For 12V, please series connects with the resistance of 1K(≥1/4 W).
For 24V, please series connects with the resistance of 2K(≥1/2 W).

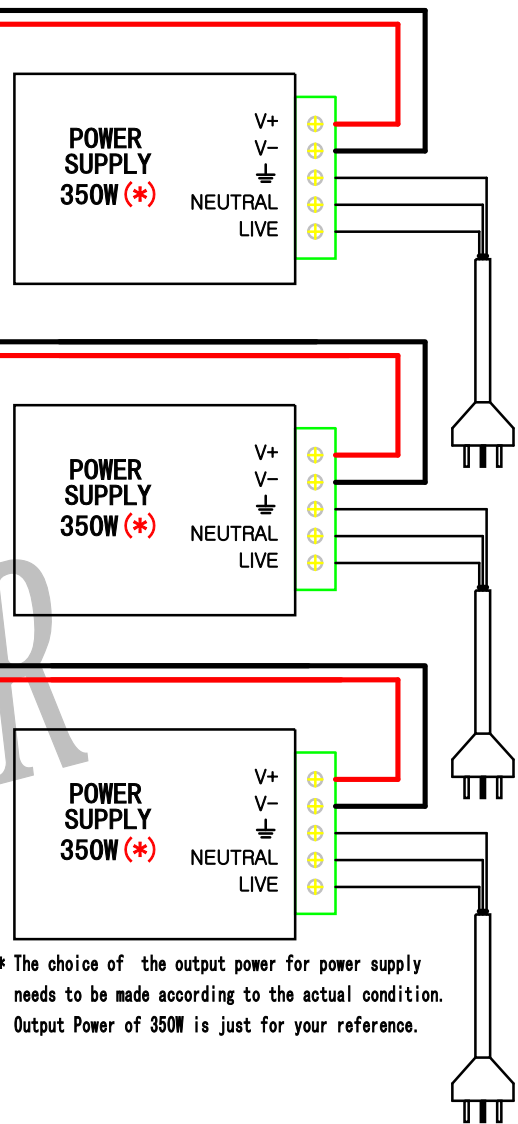

* The choice of the output power for power supply needs to be made according to the actual condition. Output Power of 350W is just for your reference.

NOTE: when you don't use enbl ports, no need to connect enbl ports

旧底图号

底图总号

日期 签名

格式 (1)

				BREAK OUT BOARD+860*3-8-2			CHANGZHOU LONGS MOTOR CO., LTD WWW.LONGS-MOTOR.COM		
更改标记	更改单号	签名	日期	等级标记	重量	比例			
设计	LEO		2016.4.8						
审核									
更新	LEO		2018.7.31	1	共	张			
标准化									
批准									

制图:

插图:

幅面: 3#