

LOWRIDER2 CNC PLASMA CONTROL PANEL

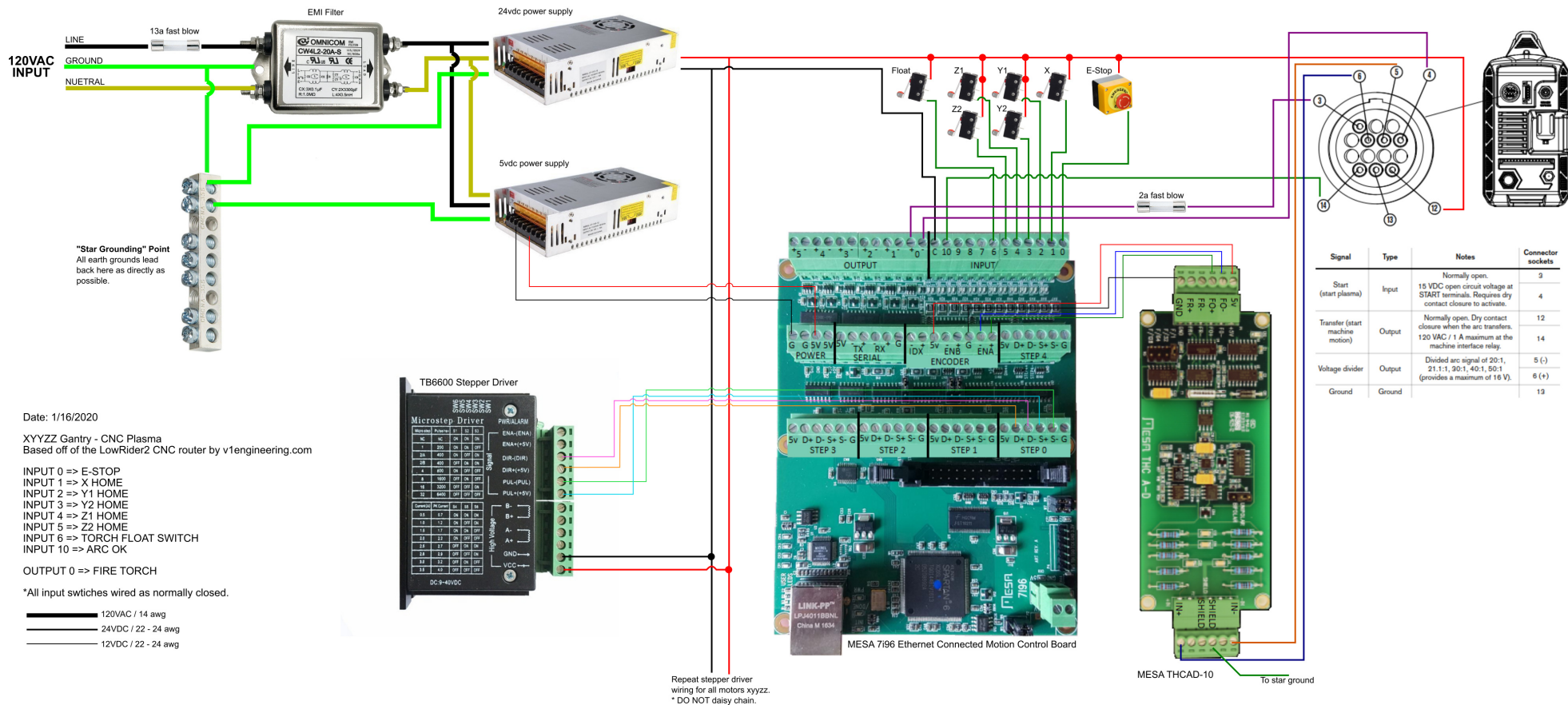

Date: 1/16/2020

XYZZ Gantry - CNC Plasma
Based off of the LowRider2 CNC router by v1engineering.com

INPUT 0 => E-STOP
INPUT 1 => X HOME
INPUT 2 => Y1 HOME
INPUT 3 => Y2 HOME
INPUT 4 => Z1 HOME
INPUT 5 => Z2 HOME
INPUT 6 => TORCH FLOAT SWITCH
INPUT 10 => ARC OK

OUTPUT 0 => FIRE TORCH

*All input switches wired as normally closed.

— 120VAC / 14 awg
— 24VDC / 22 - 24 awg
— 12VDC / 22 - 24 awg

Repeat stepper driver wiring for all motors xyzzyz.
* DO NOT daisy chain.