

RM08 super small non-contact rotary encoder

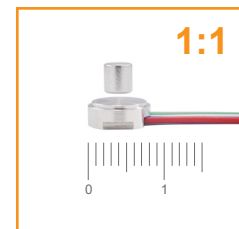
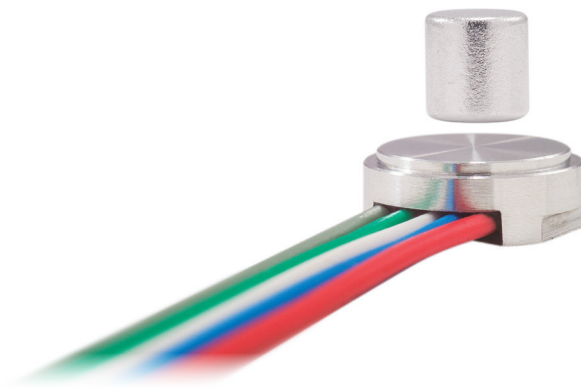

The RM08 is a compact, sealed, super small, high speed rotary magnetic encoder designed for use in space limited applications. The non-contact two part design removes the need for seals or bearings ensuring long-term reliability and simple installation.

The encoder consists of a magnet and a separate sensor board. Rotation of the magnetic actuator is sensed by a custom encoder chip within the body, and processed to give analogue, incremental, SSI or linear voltage outputs.

The encoder chip processes the signals received to provide resolutions up to 12 bit (4,096 counts per revolution) with high operational speeds.

The compact encoder body is just 8 mm in diameter and provides degree of protection to IP68.

The RM08 encoder has been designed for direct integration into high volume OEM applications and can be used in a wide range of applications including motor control and industrial automation.

The RM08 encoders use the sensor AM4096, for details refer to [AM4096 data sheet](#).

Product range

RM08A

Analogue sine/cosine, one period/revolution.

RM08I

Incremental with 8 to 1,024 pulses per revolution (up to 4,096 counts per revolution).

RM08S

Synchro serial with 5 to 12 bit resolution (up to 4,096 positions per revolution).

RM08V

Linear voltage with ramp from 0 V to 5 V.

- Super small size – 8 mm diameter body
- Non-contact, frictionless design
- 3.3 V or 5 V power supply versions
- High speed operation up to 30,000 rpm
- Industry standard analogue sinusoidal, incremental, SSI and linear voltage output formats
- Accuracy up to $\pm 0.3^\circ$

Dimensions

Dimensions and tolerance in mm.

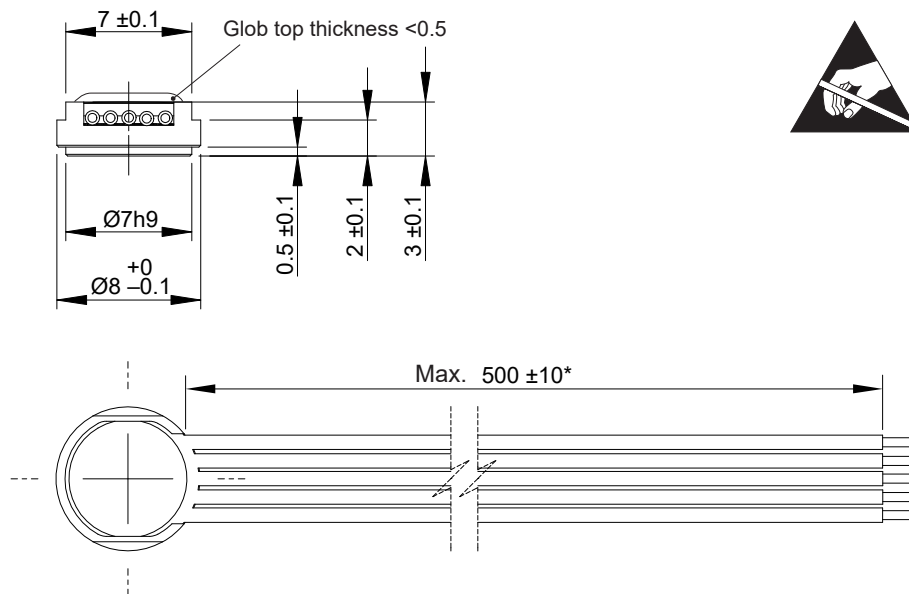

NOTE: Number of wires depends on output type.

* For cable lengths above 0.5 m, see [FAQ](#)

Mounting instructions

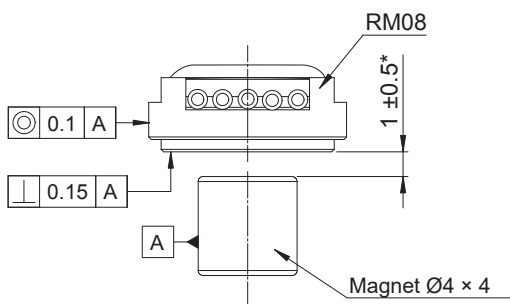

* $0.5 \text{ mm} \pm 0.2 \text{ mm}$ for $\text{Ø}3 \times 1 \text{ mm}$ magnet
(more info: see part numbering on page 10).

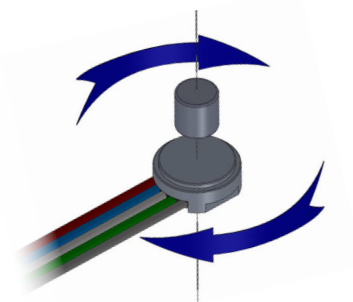

Clockwise rotation of magnet.

Technical specifications

Mechanical data	
Encoder housing material	Aluminium
Encoder mass	< 2 g (with 200 mm long wires)
Wire thickness	AWG30
Magnet material	SmCo ($\text{Sm}_2\text{Co}_{17}$), NiCuNi coated
Magnet mass	0.4 g
Shock	Half-sine 100 g, according to IEC 60068-2-27, Ed. 4
Steady-state acceleration	700 g, according to IEC 60068-2-27, Ed. 2
Environmental data	
IP protection	IP68
Operating and storage temperature	-40 °C to $+85 \text{ °C}$

RM08AC - Analogue sinusoidal

Two sinusoidal output signals (90° phase shifted, single ended)

Power supply	$V_{dd} = 5\text{ V or } 3.3\text{ V} \pm 5\%$
Current consumption	Typ. 26 mA
Sinusoidal outputs	
Signal amplitude (A)	$0.8\text{ V} \pm 0.2\text{ V}$
Signal offset (Agnd)	$1.55\text{ V} \pm 5\text{ mV}$
Phase difference	$90^\circ \pm 0.2^\circ$
Maximum speed	30,000 rpm
Temperature	$-40\text{ }^\circ\text{C to } +85\text{ }^\circ\text{C}$

* Valid for $\varnothing 4 \times 4\text{ mm}$ magnets only.

Connections

Signal	Colour
V_{dd}	Red
GND	Blue
Sin	White
Cos	Grey

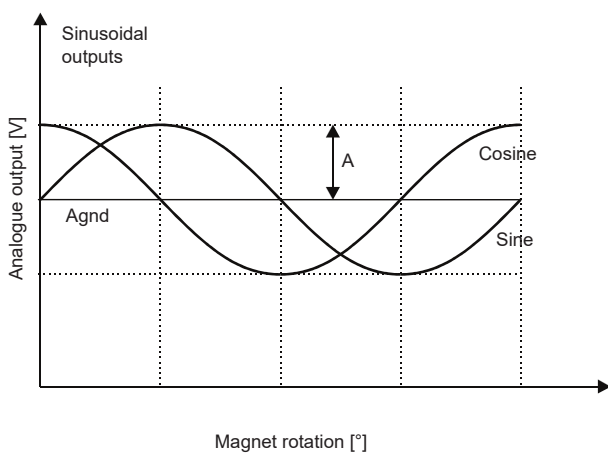

Fig. 1: Timing diagram for clockwise rotation of magnet

RM08ID - Incremental output, single ended, 5 V

Power supply	$V_{dd} = 5\text{ V or }3.3\text{ V} \pm 5\%$
Current consumption	Typ. 26 mA
Output signals	A, B, Z (single ended)
Resolution	32, 64, 128, 256, 512, 1,024, 2,048, 4,096 cpr
Max. speed	30,000 rpm
Accuracy*	$\pm 0.3^\circ$
Hysteresis	0.17°
Temperature	-40 °C to +85 °C

Connections

Signal	Colour
V_{dd}	Red
GND	Blue
Z	White
B	Green
A	Grey

* Valid for $\varnothing 4 \times 4$ mm magnets only.

There are three signals for the incremental output: A, B and Z. Signals A and B are quadrature signals, shifted by 90°, and Z signal is a reference mark. The reference mark signal is produced once per revolution. The width of the Z pulse is 1/4 of the quadrature signal period and it is synchronised with the A and B signals. The position of the reference mark is at zero. Figure 2 shows the timing diagram of A, B and Z signals with clockwise rotation of the magnet. B leads A for clockwise rotation.

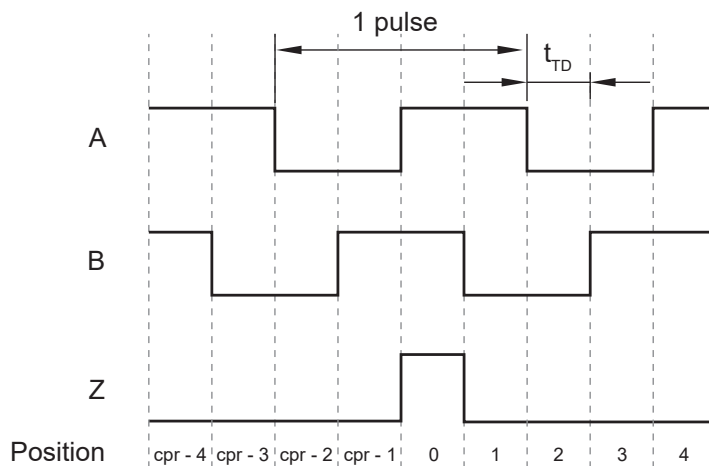

Fig. 2: Timing diagram for incremental output

The transition distance time (t_{TD}) is the time between two output position changes. The transition distance time is limited by the interpolator and the limitation is dependent on the output resolution. The counter must be able to detect the minimum transition distance to avoid missing pulses.

With incremental outputs it is important to know the difference between ppr (pulses per revolution) and cpr (counts per revolution = $4 \times \text{ppr}$). **Pulses per revolution** is the number of periods on one of the quadrature signals in one revolution. **Counts per revolution** is the number of changes of state on both channels in one revolution and is achieved by electronically multiplying by four, using both the rising and the falling edges on both channels.

RM08IC - Incremental output, RS422

Power supply	$V_{dd} = 5\text{ V or }3.3\text{ V} \pm 5\%$
Current consumption	Typ. 26 mA
Output signals	A+, B+, Z+, A-, B-, Z-
Resolution	32, 64, 128, 256, 512, 1,024, 2,048, 4,096 cpr
Max. speed	30,000 rpm
Accuracy*	$\pm 0.3^\circ$
Hysteresis	0.17°
Temperature	-25 °C to +85 °C (limited by LDB01)

* Valid for $\varnothing 4 \times 4$ mm magnets only.

RM08 with line driver board (LDB01)

Dimensions and tolerance in mm.

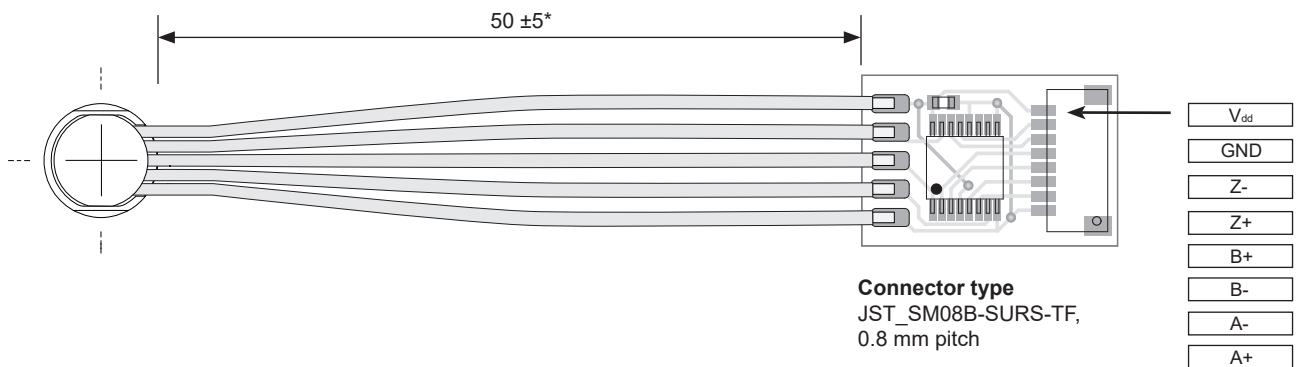

* Differential output available with soldered LDB01 and added strain relief on 50 mm distance from the RM08.

RM08SD - Synchro serial interface (SSI), single ended, 5 V

Output code	Natural binary
Power supply	$V_{dd} = 5\text{ V or } 3.3\text{ V} \pm 5\%$
Current consumption	Typ. 26 mA
SSI Data output	Data (single ended)
SSI Clock input	Clock (single ended)
Resolution	32, 64, 128, 256, 512, 1,024, 2,048, 4,096 cpr
Max. speed	30,000 rpm
Clock frequency	$\leq 4\text{ MHz}$
Accuracy*	$\pm 0.3^\circ$
Hysteresis	0.17°
Temperature	$-40\text{ }^\circ\text{C to } +85\text{ }^\circ\text{C}$

Connections

Signal	Colour
V_{dd}	Red
GND	Blue
Clock	White
Data	Green

* Valid for $\varnothing 4 \times 4\text{ mm}$ magnets only.

Serial output data is available in up to 12 bit natural binary code through the SSI protocol. With the clockwise magnet rotation, the value of the output data increases.

Parameter	Symbol	Min.	Typ.	Max.	Unit
Clock period	t_{CL}	0.25		$2 \times t_m$	μs
Clock high	t_{CHH}	0.1		t_m	μs
Clock low	t_{CLO}	0.1		t_m	μs
Monoflop time	t_m	15	19	25	μs

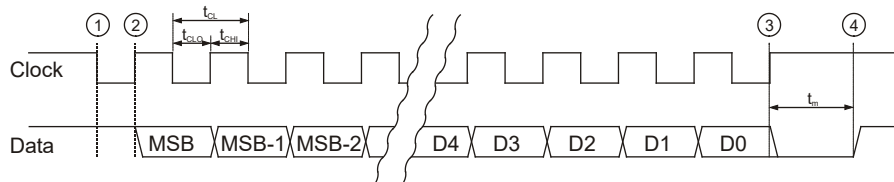

Fig. 3: Timing diagram for SSI output

The controller interrogates the encoder for its positional value by sending a pulse train to the Clock input. The Clock signal must always start from high. The first high/low transition (point 1) stores the current position data in a parallel/serial converter and the monoflop is triggered. With each transition of the Clock signal (high/low or low/high) the monoflop is retriggered. At the first low/high transition (point 2) the most significant bit (MSB) of the binary code is transmitted through the Data pin to the controller. At each subsequent low/high transition of the Clock the next bit is transmitted to the controller. While reading the data the t_{CHH} and t_{CLO} must be less than t_{mMin} to keep the monoflop set. After the least significant bit (LSB) is output (point 3) the Data goes to low. The controller must wait longer than t_{mMax} before it can read updated position data. At this point the monoflop time expires and the Data output goes to high (point 4).

If the controller continues sending the Clock pulses after the data is read without waiting for t_m , the same data will be output again and between the two outputs one logic zero will be output. The length of the data depends on the resolution of the encoder.

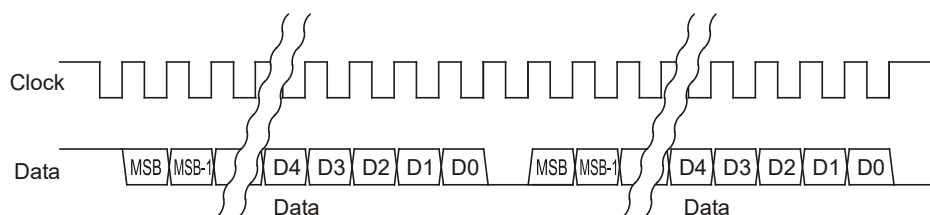

Fig. 4: SSI multi-read of the same position data

RM08SC - Synchro serial interface (SSI), RS422

Output code	Natural binary
Power supply	$V_{dd} = 5\text{ V or }3.3\text{ V} \pm 5\%$
Current consumption	Typ. 26 mA
SSI Data output	Data (RS422)
SSI Clock input	Clock (RS422)
Resolution	32, 64, 128, 256, 512, 1,024, 2,048, 4,096 cpr
Max. speed	30,000 rpm
Clock frequency	$\leq 4\text{ MHz}$
Accuracy*	$\pm 0.3^\circ$
Hysteresis	0.17°
Temperature	$-25\text{ }^\circ\text{C to }+85\text{ }^\circ\text{C}$ (limited by LDB02)

* Valid for $\varnothing 4 \times 4$ mm magnets only.

RM08 with line driver board (LDB02)

Dimensions and tolerance in mm.

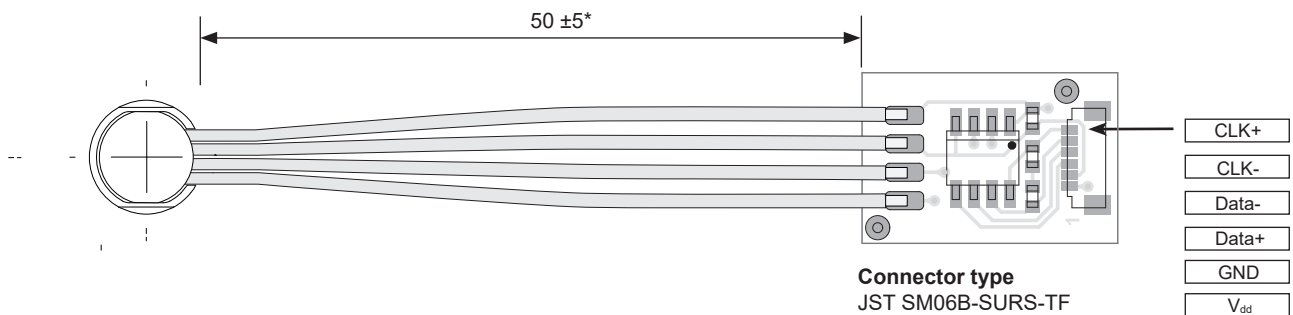

* Differential output available with soldered LDB02 and added strain relief on 50 mm distance from the RM08.

RM08Vx - Linear voltage, 5 V

Power supply	$V_{dd} = 5\text{ V} \pm 5\%$
Current consumption	Typ. 26 mA
Output voltage	0 V to V_{dd}
Output load	Max. 2 mA
Resolution of DAC	10 bit
Max. speed	30,000 rpm
Nonlinearity*	1 %
Temperature	-40 °C to +85 °C

* Valid for $\varnothing 4 \times 4$ mm magnets only.

The digital relative angular position information is converted into linear voltage with a built-in 10 bit D/A converter. The linear output voltage swing ranges from 0 V and V_{dd} (5 V). The number of periods within one revolution (N_{period}) can be 1, 2, 4 or 8, representing one full swing over an angle (φ_{period}) of 360°, 180°, 90° or 45° respectively. The signal is made up of steps which represent the angular movement needed to register a change in the position (φ_{step}) and the resulting change in the output voltage (V_{step}). The number of steps in one period (N_{step}) is given in the table below.

For clockwise rotation of the magnetic actuator, the output voltage increases. For counterclockwise rotation, the output voltage decreases.

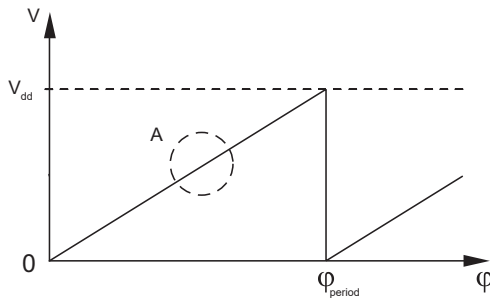
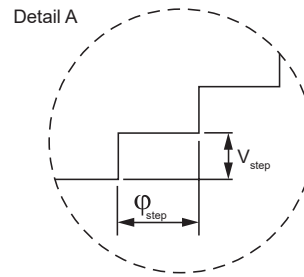

Fig. 5: Timing diagram for linear voltage output

Connections

Signal	Colour
V_{dd}	Red
GND	Blue
V_{out}	Green



$$\varphi_{\text{step}} = \frac{\varphi_{\text{period}}}{N_{\text{step}}} \quad V_{\text{step}} = \frac{V_{dd}}{N_{\text{step}}}$$

- φ_{period} = Angle covered in one period (one sawtooth)
- V_{period} = Output voltage range for one period
- φ_{step} = Step angle (angular movement needed to register a change in the position)
- V_{step} = Output voltage range for one step
- N_{period} = Number of periods in one revolution
- N_{step} = Number of steps in one period

φ_{period}	N_{period}	N_{step}	φ_{step}
360°	1	1024	0.35°
180°	2	1024	0.18°
90°	4	1024	0.09°
45°	8	512	0.09°

Output type and electrical variant

φ_{period}	360°	180°	90°	45°
Rotation				
Clockwise	VA	VB	VC	VD
Counterclockwise	VE	VF	VG	VH

Part numbering

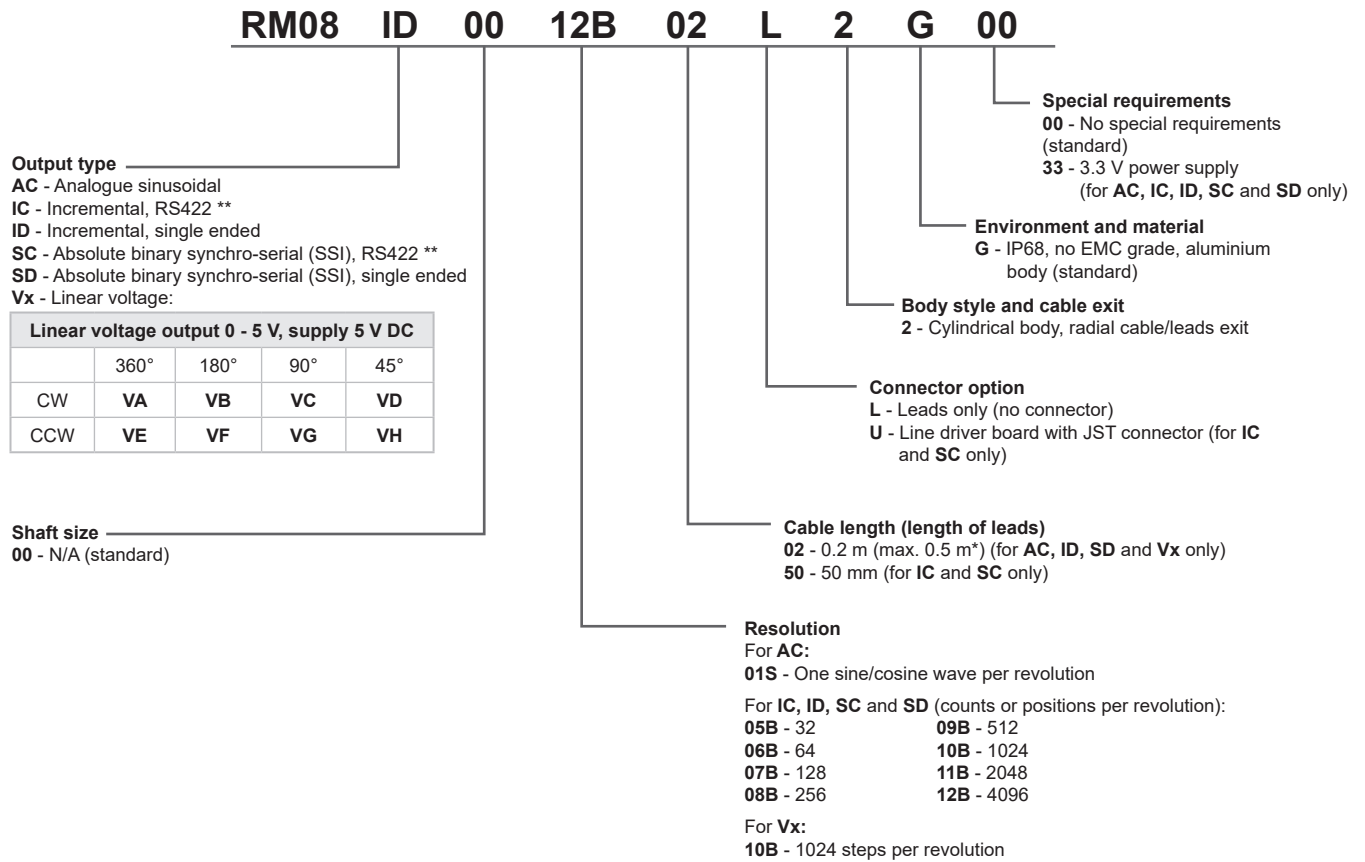

* For cable lengths above 0.5 m, see [FAQ](#).

** Differential output available with soldered LDB01/LDB02 and added strain relief on 50 mm distance from the RM08. See image below.

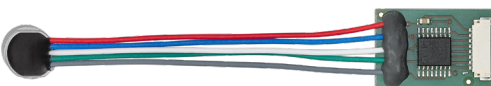

Magnet ordering information

Magnet for direct recessing in non-ferrous shafts

Fixing: Glue (recommended - LOCTITE 648 or LOCTITE 2701)

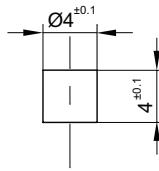

Part numbers:

For resolutions up to 9 bit absolute (512 cpr incremental)
RMM44A2A00 (individually packed) – for sample quantities only
RMM44A2C00 (packed in tubes)

For resolutions from 10 bit absolute (800 cpr incremental) and above
RMM44A3A00 (individually packed) – for sample quantities only
RMM44A3C00 (packed in tubes)

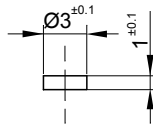

Part number:

RMM3010A1B00

NOTE: RMM3010 magnets are only tested (not graded). Specified accuracy cannot be achieved by using magnet RMM3010.

Accessories part numbering

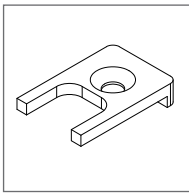

Mounting bracket
ACC014

Mounting bracket dimensions

Dimensions and tolerance in mm.

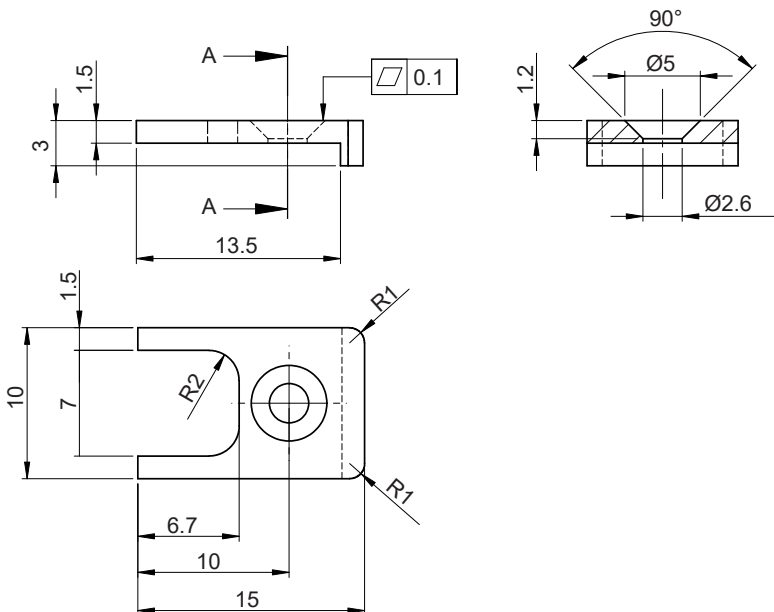

Accessories part numbering continued

Line driver board part numbers



Line driver board for
incremental output
LDB01

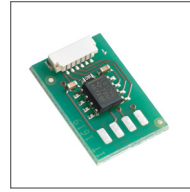

Line driver board for
SSI output
LDB02

Line driver board dimensions

Dimensions and tolerance in mm.

LDB01

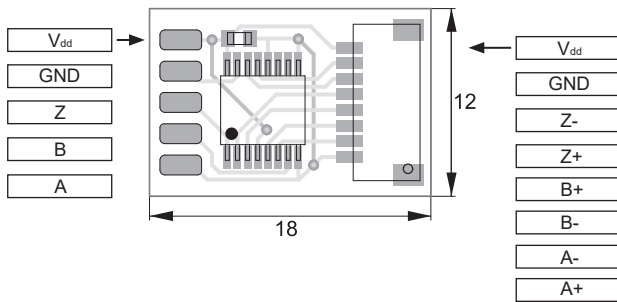

LDB02

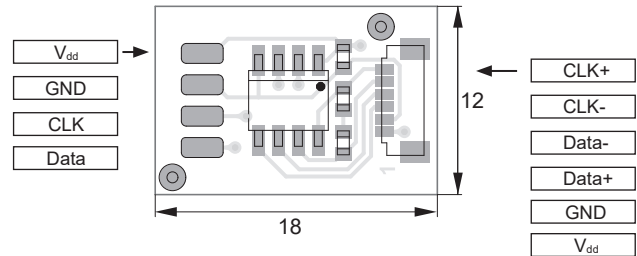

Cable assembly for LDB01
ACC033, ACC034

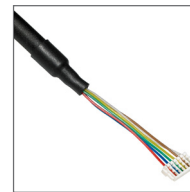

Cable assembly for LDB02
ACC031, ACC032

Cables specifications

Cable specifications	M-9693-2350-01-C
Configuration	10 × 0.0320 mm ²
Sheath color	Black
Rated voltage	30 V
Temperature range	From -40 °C to +90 °C

Cables dimensions

Dimensions and tolerance in mm.

ACC033, ACC034

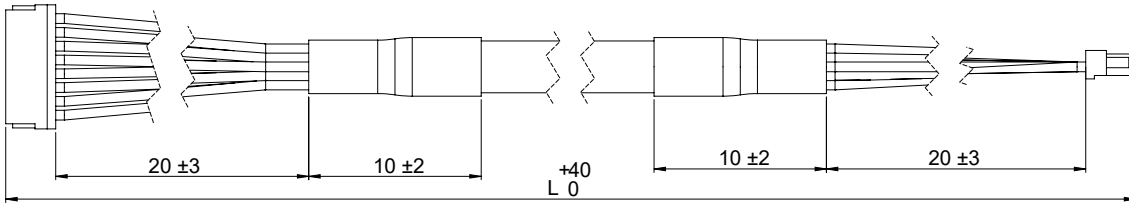

Part number	Cable length (L)
ACC033	1 m
ACC034	0.5 m

Pin	Wire color
1	Grey
2	Pink
3	Yellow
4	Green
5	White
6	Brown
7	Blue
8	Red

ACC031, ACC032

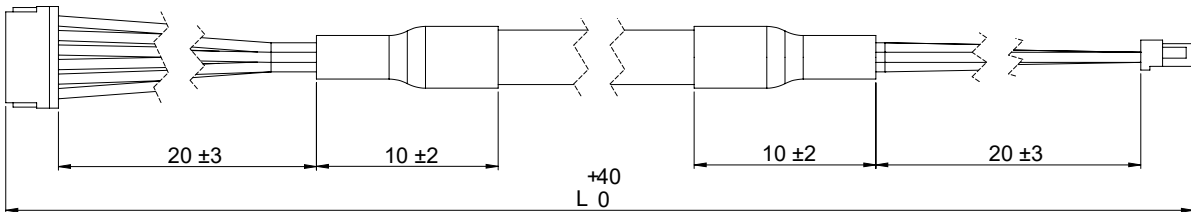

Part number	Cable length (L)
ACC031	1 m
ACC032	0.5 m

Pin	Wire color
1	Red
2	Blue
3	Green
4	Yellow
5	Brown
6	White

Head office

RLS merilna tehnika d.o.o.

Poslovna cona Žeje pri Komendi
Pod vrbami 2
SI-1218 Komenda
Slovenia

T +386 1 5272100

F +386 1 5272129

E mail@rls.si

www.rls.si

Document issues

Issue	Date	Page	Corrections made
10	28. 11. 2016	2	Shock and steady-state acceleration added, dimensions drawing amended
		9	Accessories added
11	16. 2. 2017	3	Signal amplitude amended
12	3. 12. 2018	8	Comment on cable length added
13	3. 2. 2020	5	IC output added
		7	SC output added
		10	Part numbering amended
14	15. 5. 2020	5, 7, 11	LDB01 and LDB02 pinout amended
		5, 7	Line driver wires length amended
15	12. 11. 2021	5	LDB01 connector type amended

This product is not designed or intended for use outside the environmental limitations and operating parameters expressly stated on the product's datasheet. Products are not designed or intended for use in medical, military, aerospace, automotive or oil & gas applications or any safety-critical applications where a failure of the product could cause severe environmental or property damage, personal injury or death. Any use in such applications must be specifically agreed to by seller in writing, and is subject to such additional terms as the seller may impose in its sole discretion. Use of products in such applications is at buyer's own risk, and buyer will indemnify and hold harmless seller and its affiliates against any liability, loss, damage or expense arising from such use. Information contained in this datasheet was derived from product testing under controlled laboratory conditions and data reported thereon is subject to the stated tolerances and variations, or if none are stated, then to tolerances and variations consistent with usual trade practices and testing methods. The product's performance outside of laboratory conditions, including when one or more operating parameters is at its maximum range, may not conform to the product's datasheet. Further, information in the product's datasheet does not reflect the performance of the product in any application, end-use or operating environment buyer or its customer may put the product to. Seller and its affiliates make no recommendation, warranty or representation as to the suitability of the product for buyer's application, use, end-product, process or combination with any other product or as to any results buyer or its customer might obtain in their use of the product. Buyer should use its own knowledge, judgment, expertise and testing in selecting the product for buyer's application, end-use and/or operating environment, and should not rely on any oral or written statement, representation, or samples made by seller or its affiliates for any purpose. EXCEPT FOR THE WARRANTIES EXPRESSLY SET FORTH IN THE SELLER'S TERMS AND CONDITIONS OF SALE, SELLER MAKES NO WARRANTY EXPRESS OR IMPLIED WITH RESPECT TO THE PRODUCT, INCLUDING ANY WARRANTY OF MERCHANTABILITY OR FITNESS FOR ANY PARTICULAR PURPOSE, WHICH ARE DISCLAIMED AND EXCLUDED. All sales are subject to seller's exclusive terms and conditions of sale which, where the seller is (a) RLS merilna tehnika d.o.o., are available at <https://www.rls.si/customer-service>, (b) Renishaw, Inc., are available at <http://www.renishaw.com/Shop/legal/en/-42186>, or (c) another person, are available on request, and in each case, are incorporated herein by reference, and are the exclusive terms of sale. No other terms and conditions apply. Buyer is not authorized to make any statements or representations that expand upon or extend the environmental limitations and operating parameters of the products, or which imply permitted usage outside of that expressly stated on the datasheet or agreed to in writing by seller.

RLS merilna tehnika d.o.o. has made considerable effort to ensure the content of this document is correct at the date of publication but makes no warranties or representations regarding the content. RLS merilna tehnika d.o.o. excludes liability, howsoever arising, for any inaccuracies in this document. © 2021 RLS d.o.o.