

Connection of Spindle

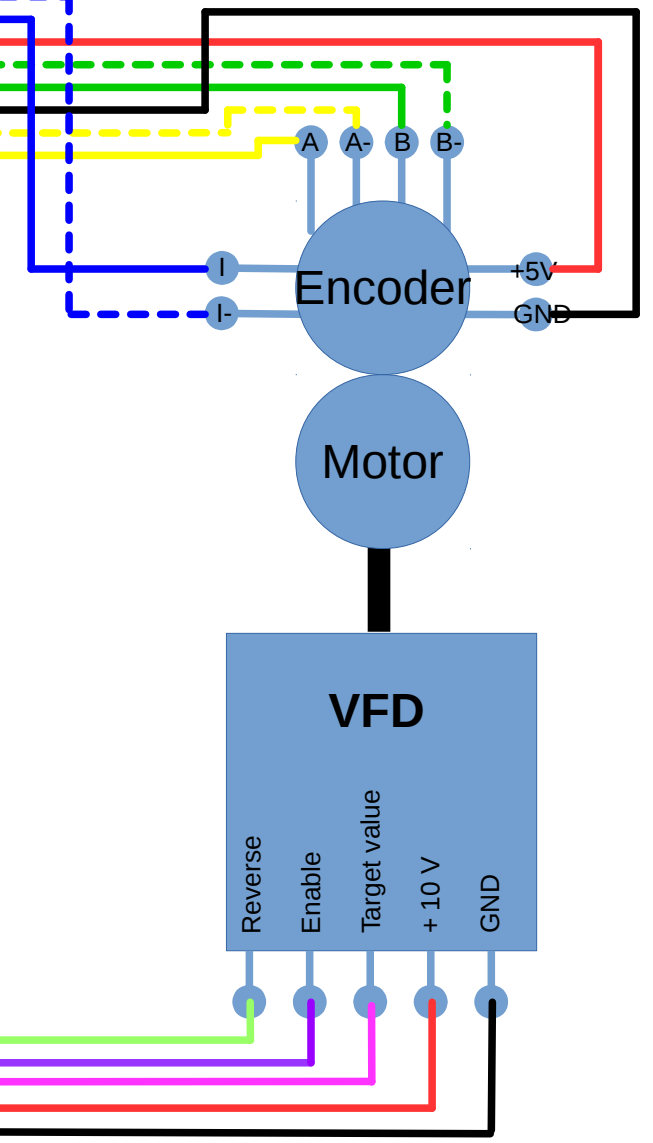
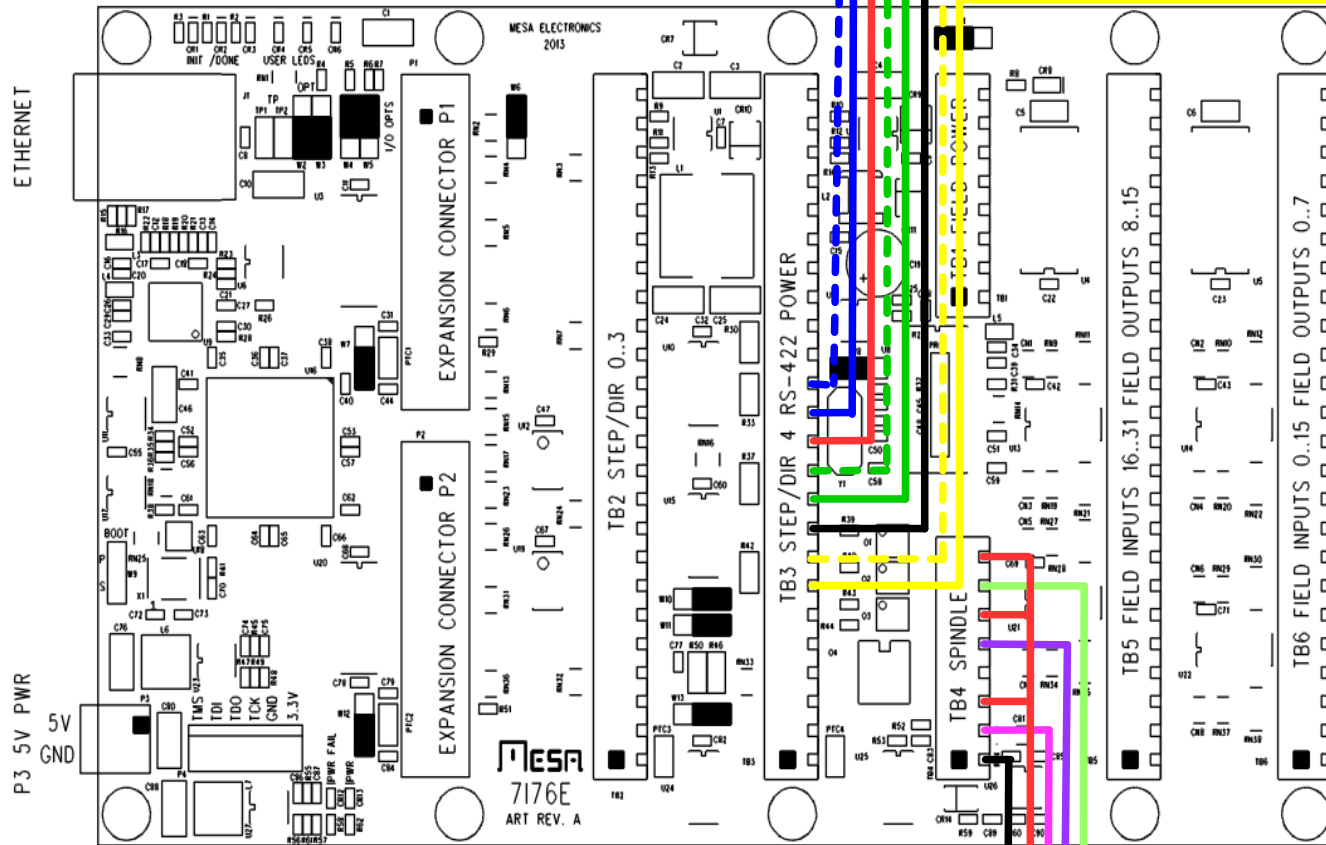

- TB3 : Encoder**
- - - - - PIN 14 = Index -
 - PIN 13 = Index
 - PIN 12 = + 5 V
 - - - - - PIN 11 = B -
 - PIN 10 = B
 - PIN 9 = GND
 - - - - - PIN 8 = A-
 - PIN 7 = A

- TB4 : Spindle**
- PIN 8 = Spindle DIR +
 - PIN 7 = Spindle DIR -
 - PIN 6 = Spindle Enable +
 - PIN 5 = Spindle Enable -
 - PIN 4 = not connected
 - PIN 3 = Spindle +
 - PIN 2 = Spindle OUT
 - PIN 1 = Spindle -