

→ CW ROTATION VIEWED FROM OUTPUT SHAFT END
ENCODER OUTPUT PHASE

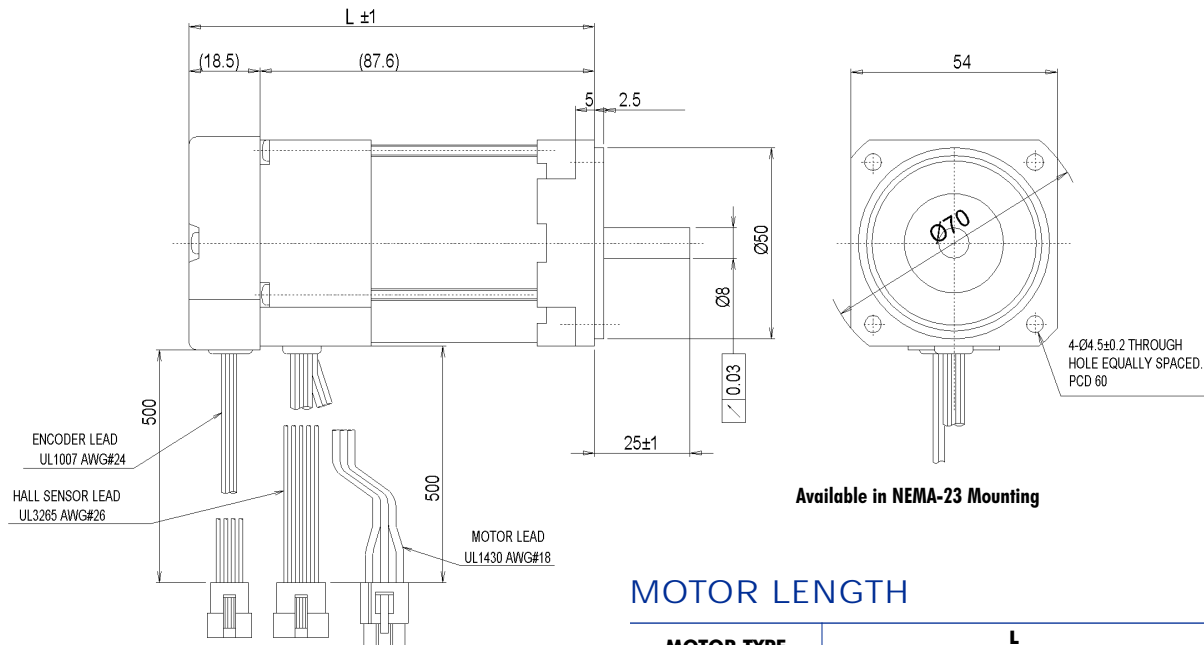

Available in NEMA-23 Mounting

MOTOR LENGTH

MOTOR TYPE	L	
	TYPE 1*	TYPE 2*
LA052-040E	85	86.1
LA052-080E	85	86.1
LA052-110E	105	106.1

* See Encoder Specification on previous page