

STEPPERONLINE®

User Manual

CL86T (V4.1)

Closed Loop Stepper Driver

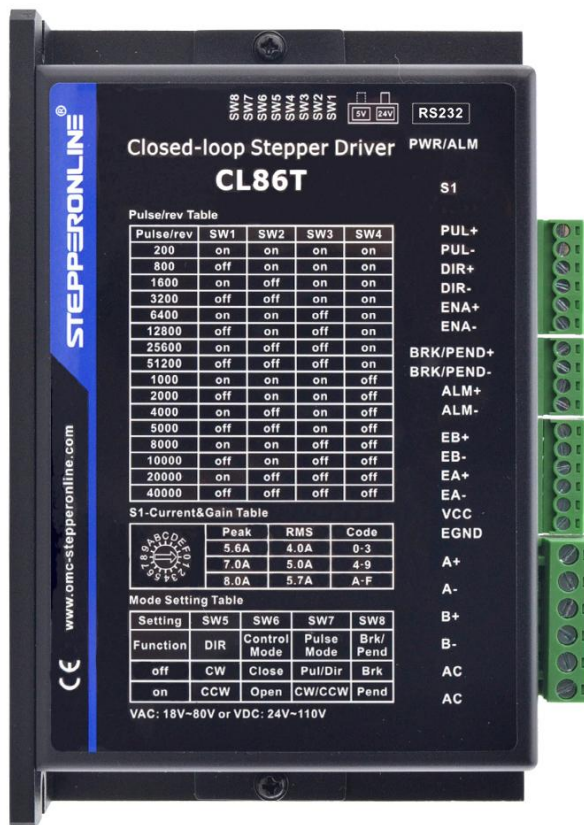

Revision 4.1

Record of Revisions

Revision	Date	Description of Release
1.00	Aug, 2019	Initial Release
4.00	Oct, 2020	Add rotating switch, 5/24V selector switch, brake output.
4.10	May, 2023	Add connector P5 -tuning port and description

Table of Content

1. Features	1
2. Specifications	1
2.1 Electrical Specifications	1
2.2 Environment	1
2.3 Mechanical Specifications	2
2.4 Heat Dissipation	2
3. Connections and LED Indication	3
3.1 Control and Digital Output Connections	3
3.2 Encoder Signals Input Connector	3
3.3 Motor Connector	4
3.4 Debug Port	4
3.5 LED Status Lights	4
4. Power Supply Selection	4
4.1 Power Supply Sharing	4
4.2 Selecting Supply Voltage	5
5. Switch Configurations	5
5.1 Rotating Switch Configurations	5
5.2 DIP Switch Configurations	6
5.2.1 Micro Step (SW1-SW4)	6
5.2.2 Mode Setting (SW5 - SW8)	7
6. Typical Connection	7
6.1 Digital Input Connection	7
6.2 Fault Output Connection	7
6.3 Brake Output Connection	8
7. Sequence Chart of Control Signals	8
8. Fault Protections & Troubleshooting	9

1. Features

- Input voltage 18-80VAC or 24-110VDC
- No loss of step, No tuning
- 500 KHz max pulse input frequency
- Resolutions of 200-51,200 via DIP switches SW1 - SW4
- 2 out current settings and gain tuning via S1 rotating switch
- Optically isolated inputs with 5V or 24V
- Motor rotating direction setting by SW5
- Closed loop or open loop control setting by SW6
- Step&Direction or CW&CCW pulse type setting by SW7
- Configure position reach output or brake output by SW8
- Over-voltage, over-current protections, position following error, etc

2. Specifications

2.1 Electrical Specifications

Parameters	Min	Typical	Max	Unit
Peak Current	5.6A (RMS 4A)	7A (RMS 5A)	8A (RMS 5.7A)	A
Operating Voltage	18 24	-	80 110	VAC VDC
Logic input signal current	7	10	20	mA
High speed pulse input frequency (5V)	0	-	500	kHz
Pulse input frequency (24V)	0	-	200	kHz
Input signal voltage	5	-	24	VDC
Logic current output	-	-	100	mA

2.2 Environment

Cooling	Natural Cooling or Forced Cooling	
Operating Environment	Environment	Avoid dust, oil fog and corrosive gases
	Humidity	40%RH – 90%RH
	Operating Temperature	0°C – 40°C (32°F - 102°F)
	Vibration	10-50Hz / 0.15mm
Storage Temperature	-20°C – 65°C (-4°F - 149°F)	
Weight	Approx. 600g	

2.3 Mechanical Specifications

(unit: mm [1inch=25.4mm])

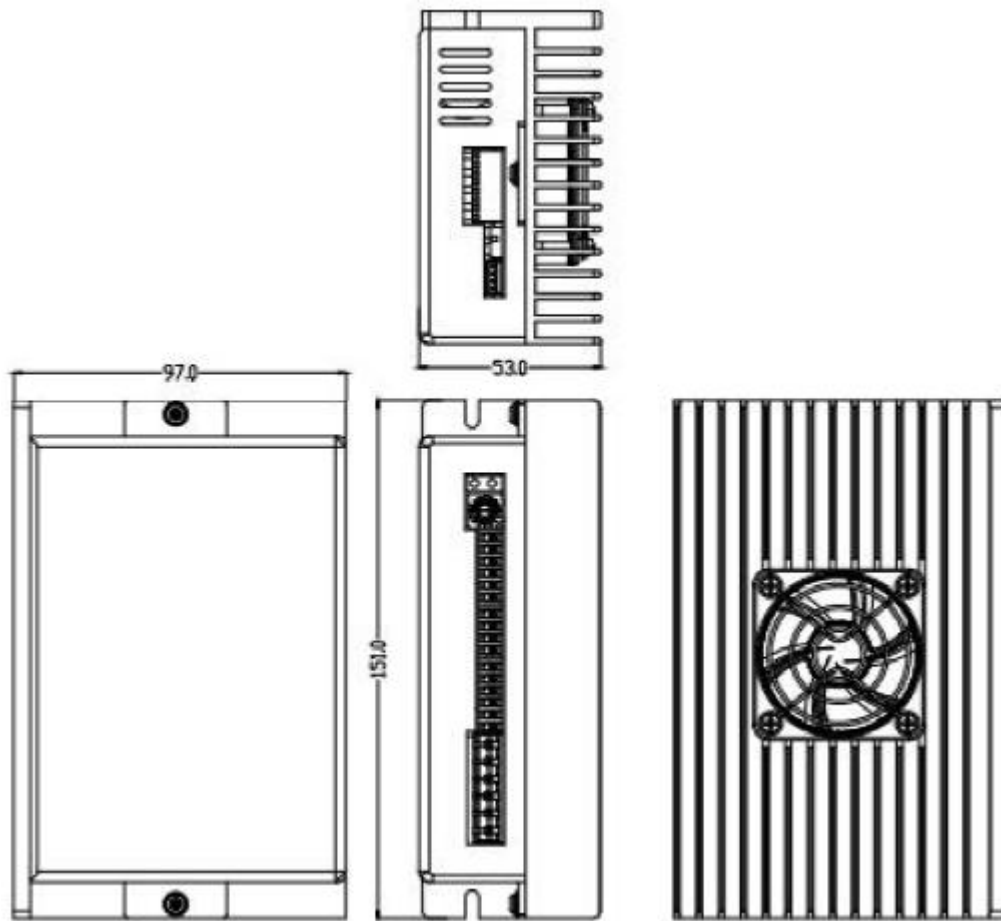

Figure 1: Mechanical specifications

2.4 Heat Dissipation

- CL86T(V4.1) reliable working temperature should be no more than 40°C (109°F)
- It is recommended to mount the drive vertically to maximize heat dissipation. Mount a cooling fan nearby if necessary.
- If multiple CL86T (V4.1) drives are installed, it is suggested to keep a minimal 30mm (1.2 inches) between two of them.

3. Connections and LED Indication

3.1 Control and Digital Output Connections

PIN	I/O	Details
PUL+ (CW+)	I	Pulse and Direction Connection: (1) Optically isolated, high level 3.5-5V or 24V, low voltage 0-0.5V (2) Maximum 500 KHz input frequency (3) The width of PUL signal is at least 1.0µs, duty cycle is recommended 50% (4) Single pulse (step & direction) or double pulse (CW/CCW) is set by DIP Switch SW7 (5) DIR signal requires advance PUL signal minimum 2 µs in single pulse mode (6) The factory setting of control signal voltage is 24V, must need to set 5V/24V rotating switch if it is 5V
PUL- (CW-)	I	
DIR+ (CCW+)	I	
DIR- (CCW-)	I	
ENA+	I	Enable Signals: Optional. (1) Effective high level is 3.5-24V; Effective low level is 0-0.5V connection (2) ENA signal requires advance DIR signal minimum 200ms in single pulse mode, (default no connection)
ENA-	I	
BRK+ (PEND+)	O	Select brake output or pend output by switch 8, default as brake output Max 30VDC/100mA
BRK- (PEND-)	O	
ALM+	O	Max 30VDC/100mA
ALM-	O	

Notes:

- (1) Shielding control signal wires is suggested;
- (2) To avoid/reduce interference, don't tie control signal cables and power wires together;
- (3) Brake output need to connect a relay and diode

3.2 Encoder Signals Input Connector

Drive Pin Name	Description
EB+	Encoder B+ input connection
EB-	Encoder B- input connection
EA+	Encoder A+ input connection
EA-	Encoder A- input connection
VCC	Encoder +5V voltage output connection
EGND	Power ground connection

3.3 Motor Connector

PIN	Details
A+	Connect to motor A+ wire
A-	Connect to motor A- wire
B+	Connect to motor B+ wire
B-	Connect to motor B- wire
AC	Available for AC input or DC input, no polarity request while DC input
AC	

3.4 Debug Port

The RS232 communication port connected to the PC has been opened.

CL86T has an RS232 tuning port, which can modify the driver parameters, but it is only used to modify the parameters, not for equipment control, and the accuracy and stability are not enough.

The interface definition is as follows:

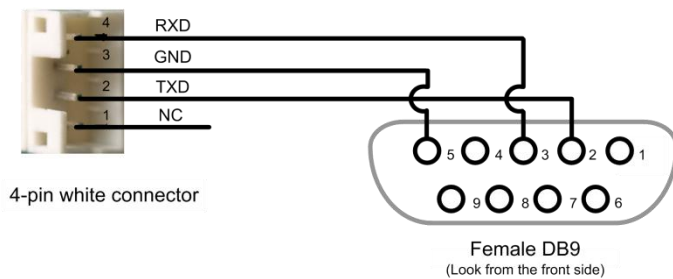

3.5 LED Status Lights

There are two LED lights. The GREEN one is the power indicator which should be always on in normal circumstance. The RED one is a alarm status indication light, which will be OFF while working normally but ON and flash some times in a 3-second period in the case of enabled alarm protections.

4. Power Supply Selection

The CL86T (V4.1) can power medium and large size stepping motors (frame size from NEMA 23 to 34). To get good driving performances, it is important to select supply voltage and output current properly. Generally speaking, supply voltage determines the high speed performance of the motor, while output current determines the output torque of the driven motor (particularly at lower speed). Higher supply voltage will allow higher motor speed to be achieved, at the price of more noise and heating. If the motion speed requirement is low, it's better to use lower supply voltage to decrease noise, heating and improve reliability.

4.1 Power Supply Sharing

Multiple CL86T (V4.1) drives can share one power supply to reduce cost, if that power supply has enough power capacity. To avoid cross interference, connect each stepper drive directly to the shared power supply

separately. To avoid cross interference, DO NOT daisy-chain connect the power supply input pins of the drivers. Instead connect them to power supply separately.

4.2 Selecting Supply Voltage

The CL86T (V4.1) is designed to operate within 24 - 110VDC or 18 - 80VAC voltage input. When selecting a power supply, besides voltage from the power supply power line voltage fluctuation and back EMF voltage generated during motor deceleration needs also to be taken into account. Please make sure leaving enough room for power line voltage fluctuation and back-EMF voltage charge back.

Higher supply voltage can increase motor torque at higher speeds (>300 RPM), thus helpful for avoiding losing steps. However, higher voltage may cause bigger motor vibration at lower speed, and it may also cause over-voltage protection or even drive damage.

5. Switch Configurations

5.1 Rotating Switch Configurations

This rotating switch is used to set the peak current of the drive and motion gain, from the motor phase current and application requirements.

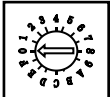
	Peak Current	Code	Velocity loop Ki	Position loop Kp	Velocity loop Kp
	5.6A	0 (factory)	0	25	25
		1	0	50	15
		2	16	25	25
		3	16	50	15
	7.0A	4	0	25	25
		5	0	50	15
		6	0	100	5
		7	16	25	25
		8	16	50	15
		9	16	100	5
	8.0A	A	0	25	25
		B	0	50	15
		C	0	100	5
		D	16	25	25
		E	16	50	15
		F	16	100	5

Remark:

- 1) Velocity loop Ki Indicates the stop time and position accuracy , “0” indicates the stop time is long, but the position error is smaller.“16” means the stop time is short, but the position error is slightly larger.
- 2) Position loop Kp and velocity loop Kp is a pair of composite parameters that represent rigidity. “25” and “25”composite parameters indicate the rigidity is weak, “100” and “5”composite parameters indicate the rigidity is strong. Sometimes if the motor will rotate after stopping, it can increase the value of position loop

Kp, but if the value is too large, the motor will have noise.

3) Usually keep factory settings

5.2 DIP Switch Configurations

The 8-bit is located on the side and used to configure settings of micro step resolution, output current, and motor standstill current as shown below

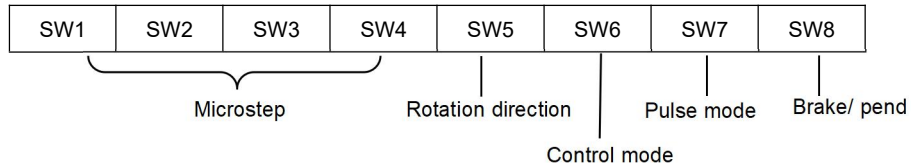

Figure 2: DIP switches

5.2.1 Micro Step (SW1-SW4)

Each CL86T (V4.1) has 16 microstep settings which can be configured through DIP switches SW1, SW2, SW3 and SW4. See the following table for detail.

Micro step	Pulses/Rev. (for 1.8°motor)	SW1	SW2	SW3	SW4
1	200 (Default)	on	on	on	on
4	800	off	on	on	on
8	1600	on	off	on	on
16	3200	off	off	on	on
32	6400	on	on	off	on
64	12800	off	on	off	on
128	25600	on	off	off	on
256	51200	off	off	off	on
5	1000	on	on	on	off
10	2000	off	on	on	off
20	4000	on	off	on	off
25	5000	off	off	on	off
40	8000	on	on	off	off
50	10000	off	on	off	off
100	20000	on	off	off	off
200	40000	off	off	off	off

5.2.2 Mode Setting (SW5 - SW8)

	Function	ON	OFF
SW5	Rotation Direction	CW (clockwise)	CCW (counterclockwise)
SW6	Control Mode	Open loop control	Closed loop control
SW7	Pulse Mode	CW/CCW (double pulse)	PUL/DIR (single pulse)
SW8	Brake/ pend	Pend output	Brake output

6. Typical Connection

6.1 Digital Input Connection

The CL86T (V4.1) can accept can accept differential or single-ended control signals (pulse, direction, and enable) in open-collector or PNP connection. It is recommend to add an EMI line filter between the power supply and the drive to increase noise immunity for the drive in interference environments.

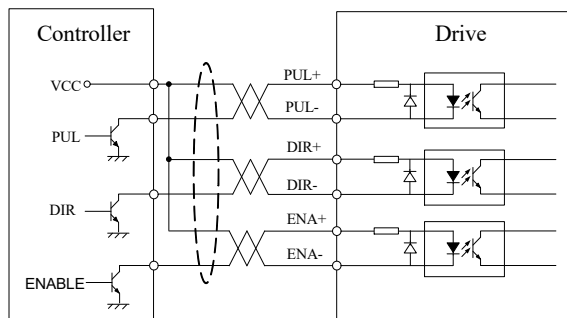

Figure 3: Connections to open-collector signal
(Common-anode)

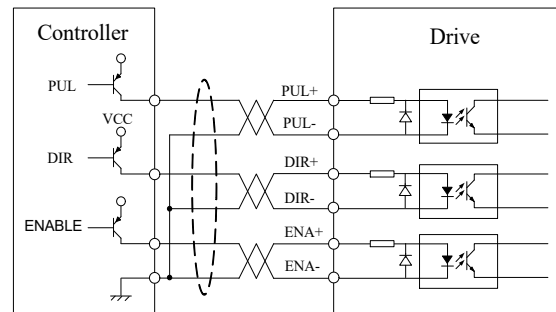

Figure 4: Connections to PNP signal
(Common-cathode)

Notes:

- (1) ENA signal is no-connected as default;
- (2) ENA signal is no connected as default, and ENA signal is available for 5V~24V.

6.2 Fault Output Connection

When over voltage or over current protection happens, CL86T(V4.1) red status LED light will blink and the impedance state between ALM+ and ALM- will change (from low to high or high to low depending on configuration) and can thus be detected. Fault output connection is optional, and it can be connected either in sinking or sourcing.

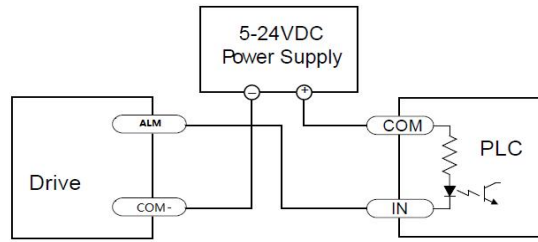

Connecting a sinking output to a PLC's input

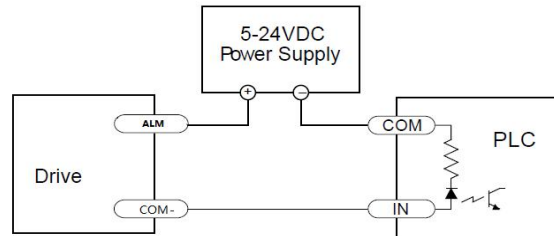

Connecting a sourcing output to a PLC's input

6.3 Brake Output Connection

This drive has a special brake output; it needs to drive the motor brake with a relay. The connection is below:

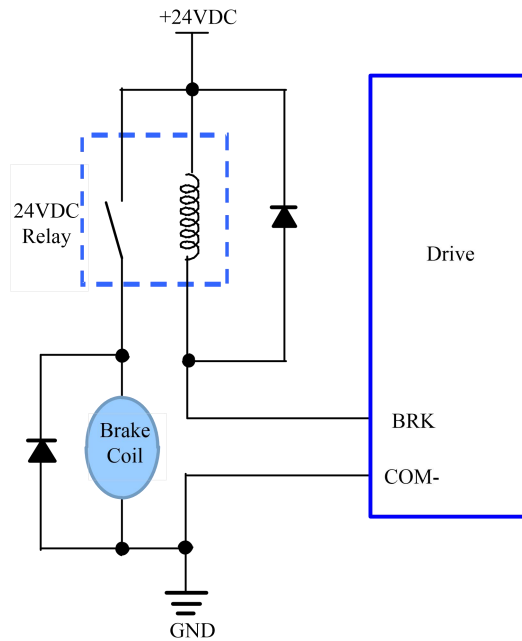

Figure 7: Brake output connection

7. Sequence Chart of Control Signals

In order to avoid some fault operations and deviations, PUL, DIR and ENA should abide by some rules, shown as following diagram:

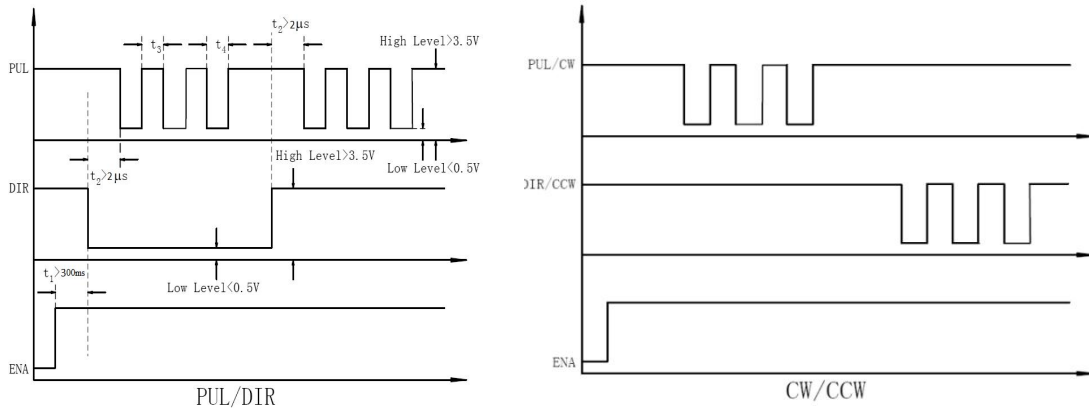

Figure 8: Sequence chart of control signals

Remark:

- a) t1: ENA must be ahead of DIR by at least 200ms. Usually, ENA+ and ENA- are NC (not connected). See “Connector P1 Configurations” for more information.
- b) t2: DIR must be ahead of PUL effective edge by 2us to ensure correct direction;
- c) t3: Pulse width not less than 1us;
- d) t4: Low level width not less than 1us;
- e) Duty cycle of PUL signal is recommended 50%.

8. Fault Protections & Troubleshooting

To improve reliability, the drive incorporates some built-in protection features.

Blink time(s)	Sequence wave of red LED	Description	Trouble shooting
1		Over-current	Turn off the power immediately. a) Check wiring is short-circuited or not; b) Check motor is short-circuited or not.
2		Over-voltage	Turn off the power immediately. a) Check if the power voltage is higher than 90VDC
3		Chip error	Restart the power supply, if the drive is still alarm, please contact after-sale
4		Fail to lock motor shaft	a) The drive is not connected to a motor; b) If alarm is occurred when connect a motor, please check the motor power cable.
5		EEPROM error	Restart the power supply, if the drive is still alarm, please contact after-sale

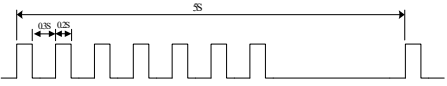
6		Fail to auto tuning	Restart the power supply, if the drive is still alarm, please contact after-sale
7		Position following error	a) Set SW6 to "ON" to make motor run in open loop mode, If alarm disappears, it means encoder wiring error; b) Motor torque is not enough or motor speed is too high;
Always	-	PCB board is burned out	Restart the power supply, if the drive is still alarm, please contact after-sale

When above protections are active, the motor shaft will be free or the red LED blinks. Reset the drive by repowering it to make it function properly after removing above problems.

In the event that your drive doesn't operate properly, the first step is to identify whether the problem is electrical or mechanical in nature. The next step is to isolate the system component that is causing the problem. As part of this process you may have to disconnect the individual components that make up your system and verify that they operate independently. It is important to document each step in the troubleshooting process. You may need this documentation to refer back to at a later date, and these details will greatly assist our Technical Support staff in determining the problem should you need assistance.

Many of the problems that affect motion control systems can be traced to electrical noise, controller software errors, or mistake in wiring.

Symptoms	Possible Problems	Solutions
Motor is not rotating	No power	Connect power supply correctly
	Microstep resolution setting is wrong	Setting appropriate microstep
	Fault condition exists	Check wiring and restart power
	The drive is disabled	Drive restore factory setting, and keep ENA+, ENA- input signals unconnected.
Wrong motor rotation direction	The Direction signal level is reverse	Toggling the SW5 DIP switch
Erratic motor motion	Control signal is too weak	Ensure the current of control signal is within 7-16mA
	Control signal is interfered	Don't tie the control signal cable with power cable together
	Wrong motor connection	Refer to user manual of drive and motor datasheet
	Something wrong with motor coil	Check the motor is normal
Motor stalls during	Current setting is too small	Choose another power supply with

acceleration		lager power or increase the output current of drive
	Motor is undersized for the application	Choose another motor with higher torque
	Acceleration is set too high	Reduce the acceleration
	Power supply voltage too low	Choose another power supply with large voltage output
Excessive motor & drive heating	Inadequate heat sinking / cooling	Refer to chapter 2.4
	Motor peak current setting is too high	Reduce the current value refer to motor datasheet
Motor vibration when power on	Speed loop Kp is too high	Reduce the speed loop Kp value